

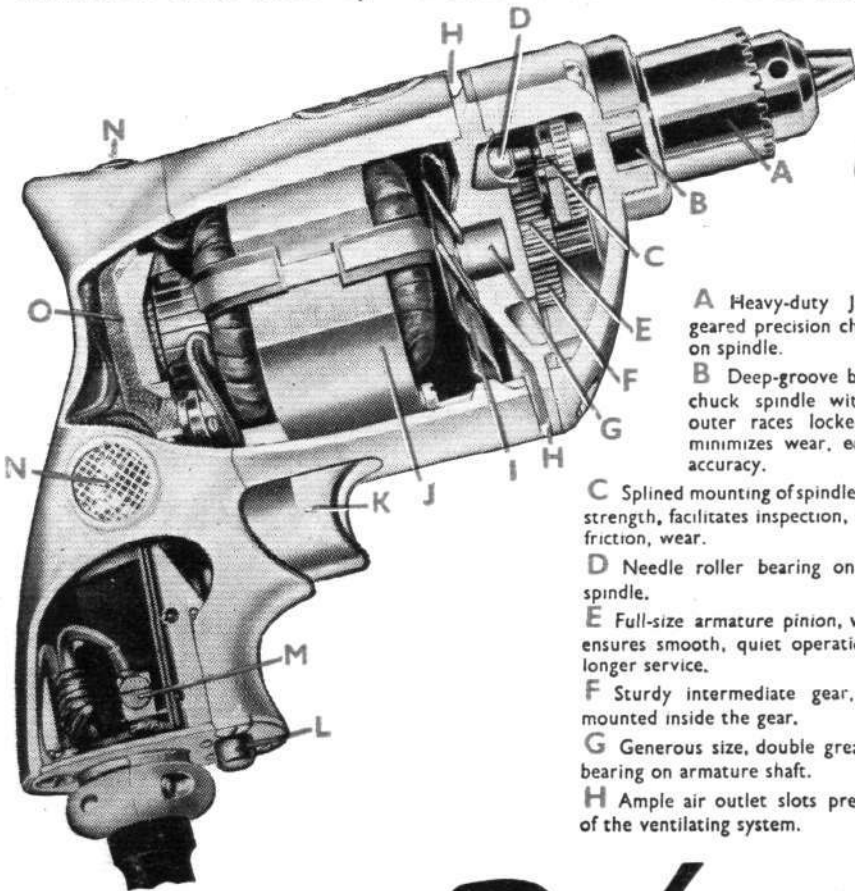

**OVER 250,000
HOLGUNS IN USE!**

This remarkable number of Holgun Drills has been produced in record time, and the service demanded from them by war-time industries

has far exceeded our claim for 1/4" lightweight drills. The Holgun has proved the lightweight drill for all industries—now and in the future...



*And here's
the reason*

- A** Heavy-duty Jacobs 3-jaw geared precision chuck, threaded on spindle.
- B** Deep-groove ball bearing on chuck spindle with inner and outer races locked in place—minimizes wear, ensures spindle accuracy.
- C** Splined mounting of spindle gear increases strength, facilitates inspection, reduces noise, friction, wear.
- D** Needle roller bearing on back end of spindle.
- E** Full-size armature pinion, with 12 teeth, ensures smooth, quiet operation, less wear, longer service.
- F** Sturdy intermediate gear, ball bearing mounted inside the gear.
- G** Generous size, double grease-sealed ball bearing on armature shaft.
- H** Ample air outlet slots prevent clogging of the ventilating system.
- I** Full-size fan mounted on armature shaft.
- J** Powerful Black & Decker Universal Motor; through-bolts hold field securely.
- K** Famous "Pistol Grip & Trigger Switch." Instant release switch control convenient for right or left-hand use.
- L** Switch-locking pin for optional use on continuous operations.
- M** Two-pole automatic release switch, locking pin, cord protector and 3-wire cable are mounted in handle as one complete unit.
- N** Three screened air inlets (on top and both sides), any two of which provide ample ventilation.
- O** Brush holders and springs mounted on moulded bakelite brush ring, locked in place by the switch handle.

Black & Decker

PORTABLE ELECTRIC TOOLS

BLACK & DECKER LTD • HARMONDSWORTH • MIDDX
 PHONE: WEST DRAYTON 2681/6. GRAMS: "BLACDECK," WEST DRAYTON
 BRANCH SERVICE STATIONS: LONDON • BIRMINGHAM • BRISTOL • GLASGOW • LEEDS • MANCHESTER • NOTTINGHAM