

BOSCH



Service



**INSTANDSETZUNGSHINWEISE
REPAIR INSTRUCTIONS
INSTRUCTIONS DE REPARATION
INSTRUCCIONES DE REPARACION**

EW / WJW 0 611 245 7 .. (2003 - 07) X

**Bohrhammer
Rotary Hammer
Marteau perforateur
Martillo perforador**

Typ 0 611 245 7 .. = GBH 11 DE

Änderungen vorbehalten. Unsere Erzeugnisse werden stets dem neuesten technischen Stand angepaßt. Deshalb behalten wir uns Änderungen vor.

Modifications. Our products are constantly modified to meet new technical standards. We therefore reserve the right to alter data and specifications without prior notice.

Modifications. Nos produits sont continuellement adaptés aux dernières nouveautés techniques et les dates sont données sous réserve de changement.

Modificaciones. Nuestros fabricados van siendo adaptos constantemente a las últimas conquistas técnicas. Por ello, tenemos que reservarnos el derecho de introducir modificaciones en los datos técnicos.

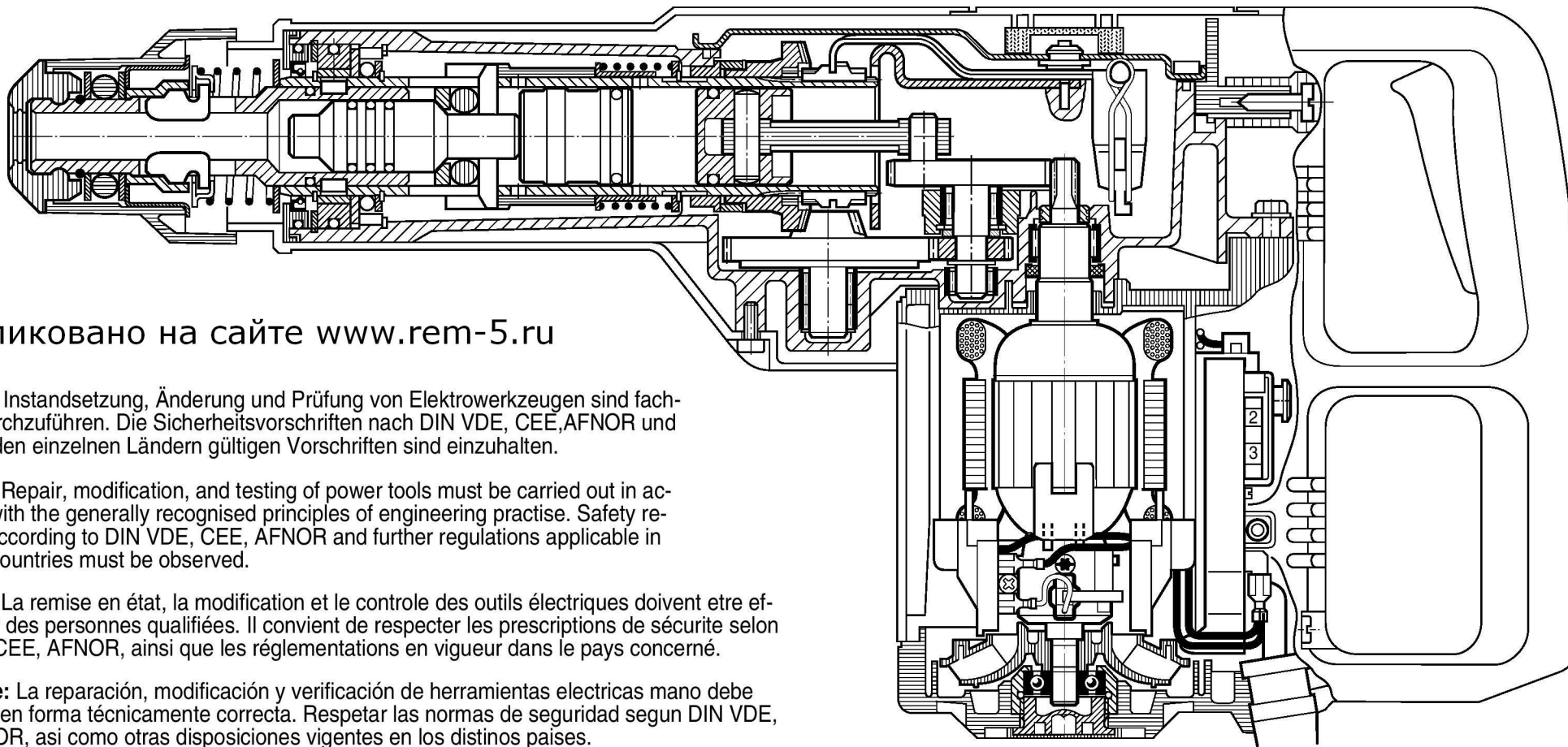

Опубликовано на сайте www.rem-5.ru

Beachten: Instandsetzung, Änderung und Prüfung von Elektrowerkzeugen sind fachgerecht durchzuführen. Die Sicherheitsvorschriften nach DIN VDE, CEE, AFNOR und weitere in den einzelnen Ländern gültigen Vorschriften sind einzuhalten.

Attention: Repair, modification, and testing of power tools must be carried out in accordance with the generally recognised principles of engineering practise. Safety regulations according to DIN VDE, CEE, AFNOR and further regulations applicable in individual countries must be observed.

Attention: La remise en état, la modification et le contrôle des outils électriques doivent être effectués par des personnes qualifiées. Il convient de respecter les prescriptions de sécurité selon DIN VDE, CEE, AFNOR, ainsi que les réglementations en vigueur dans le pays concerné.

Obsérvese: La reparación, modificación y verificación de herramientas eléctricas mano debe efectuarse en forma técnicamente correcta. Respetar las normas de seguridad según DIN VDE, CEE, AFNOR, así como otras disposiciones vigentes en los distintos países.

ROBERT BOSCH GMBH GESCHÄFTSBEREICH ELEKTROWERKZEUGE D 70745 LEINFELDEN-ECHTERDINGEN

Printed in Federal Republic of Germany - Imprimé en République Fédérale d'Allemagne

Typ 0 611 245 7 ..

Zerlegen

Für die Demontage werden handelsübliche Werkzeuge benötigt.

1. Eingangsprüfung durchführen.
Beachten:
Die Sicherheitsvorschriften nach DIN, VDE, CEE, AFNOR und weitere in den einzelnen Ländern gültigen Vorschriften sind einzuhalten.

Disassembly

Use normal trade tools by disassembly.

1. Carry out power supply check.
Attention:
Safety regulations according to DIN, VDE, CEE, AFNOR and further regulations applicable in individual countries must be observed.

Démontage

Pour le démontage, des outils en usage dans le commerce sont nécessaires.

1. Effectuer un contrôle préliminaire.
Attention:
Respecter les instructions de sécurité selon DIN, VDE, CEE, AFNOR et les autres instructions valables dans les pays respectifs.

Desmontaje

Para el desmontaje no se precisan herramientas especiales.

1. Realizar control de recepción.
Atención:
Atenerse a las prescripciones de seguridad según DIN, VDE, CEE, AFNOR y a las prescripciones adicionales específicas que pudieran existir en los respectivos países.

1.

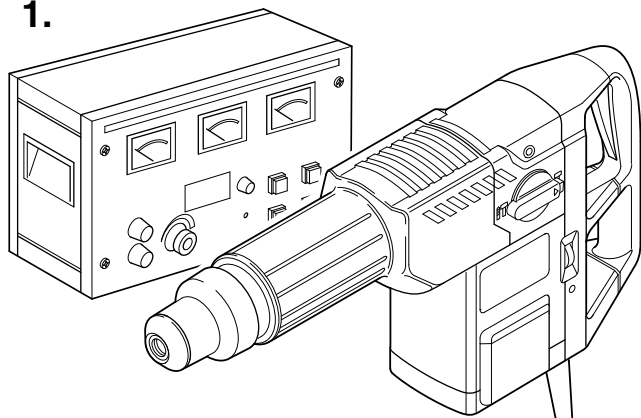

2.

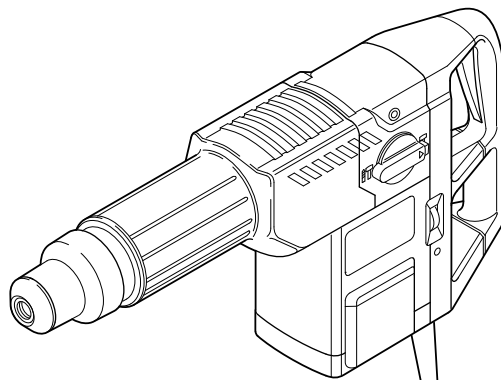

2. Zerlegen nach Explosions-, Schnittzeichnung und diesem Instandsetzungshinweis.
2. Disassembly using explosion, cut-away drawings and these repair instructions!
2. Démontez l'appareil suivant la vue éclatée, le plan en coupe et ces instructions de réparation.
2. Realizar el desmontaje conforme a los dibujos en perspectiva y en sección, y a estas instrucciones de reparación.

3.

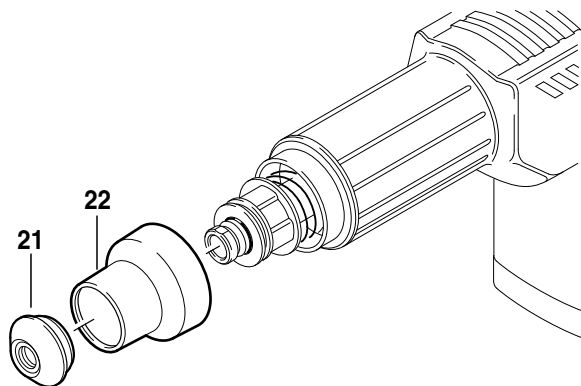

3.1

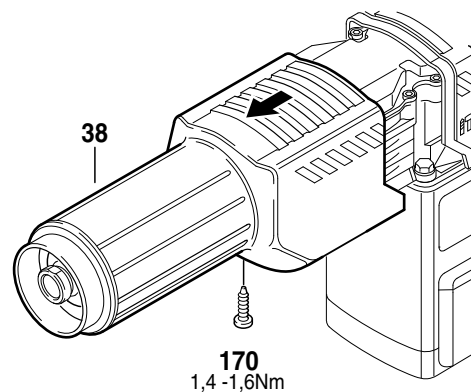

3.2

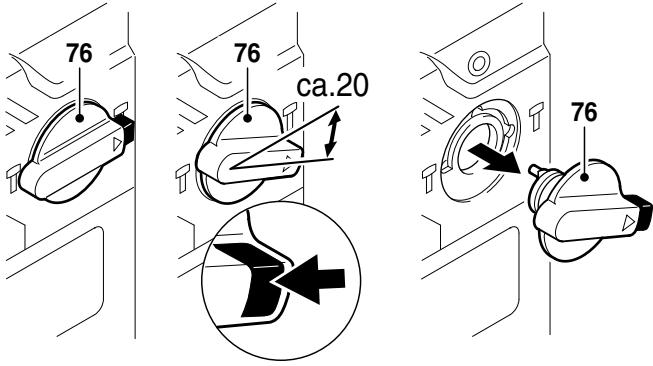

3.3

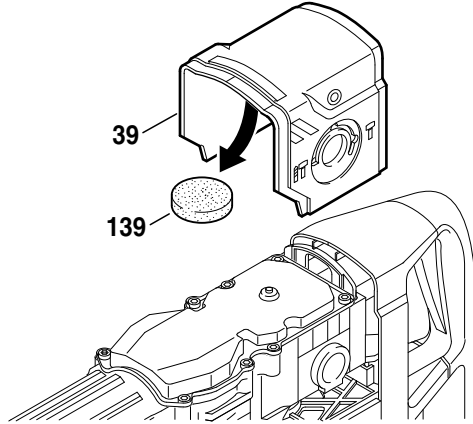

4.

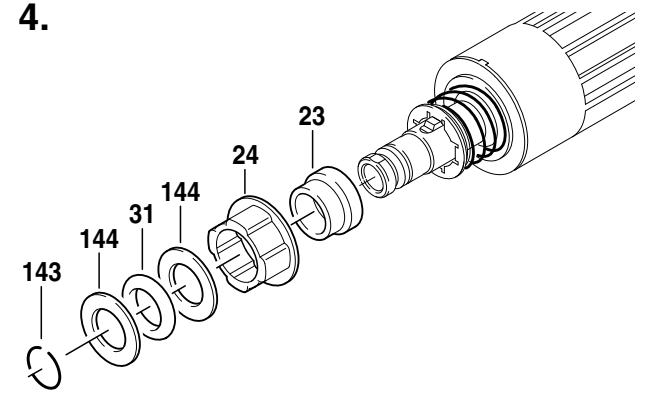

4.1

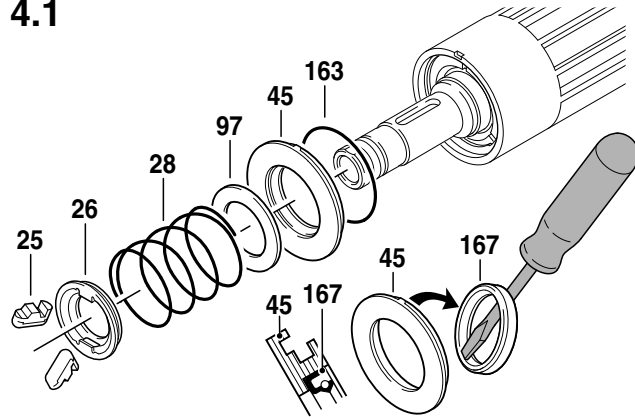

4.2

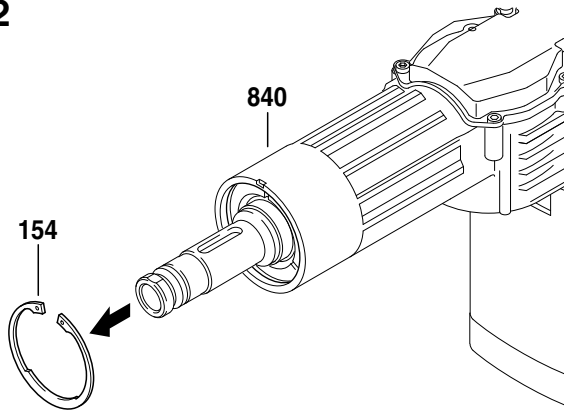

4.3

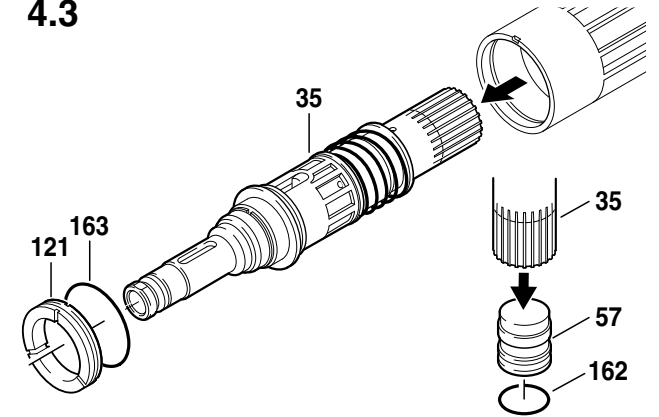

4.4

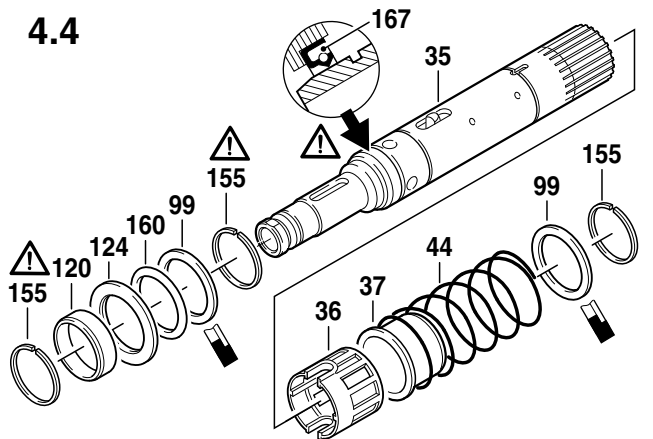

4.5

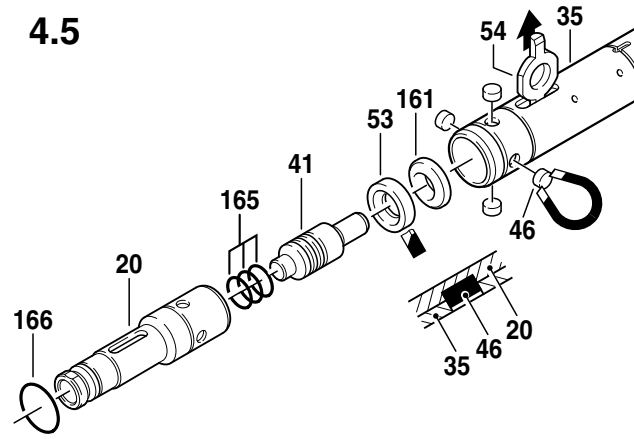

5.

4,5-5,5Nm

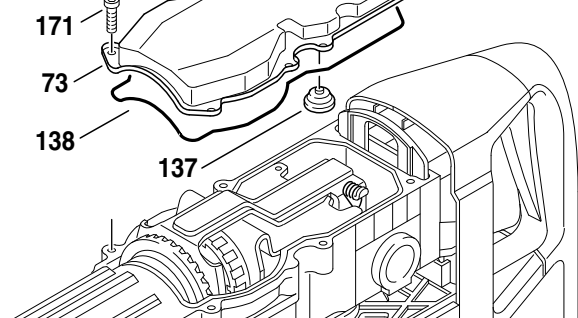

5.1

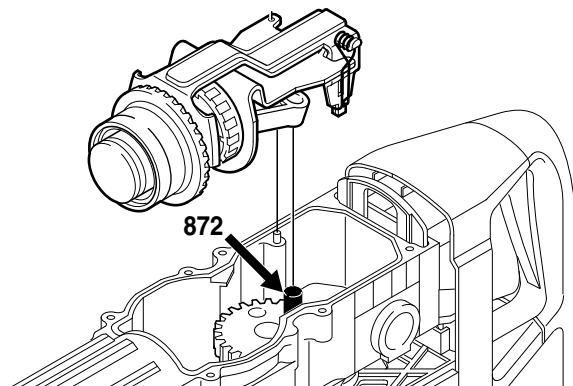

5.2

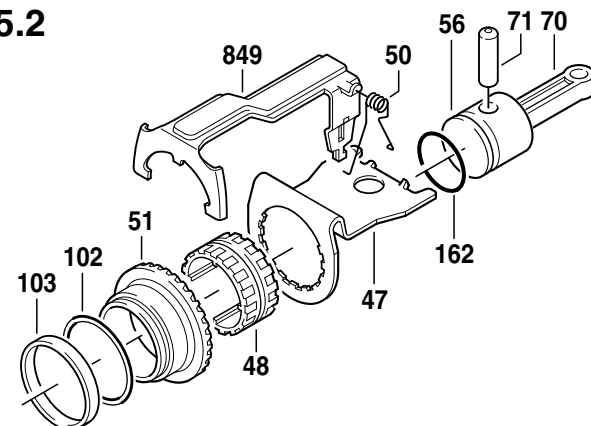

5.3

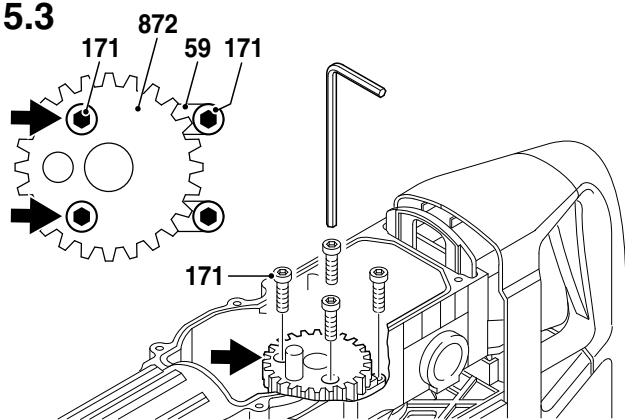

5.4

X Hilfswerkzeug zum Selbstanfertigen
 Auxiliary tool (for your own manufacture)
 Outil auxiliaire (fabrication locale)
 Utile (fabricación particular)

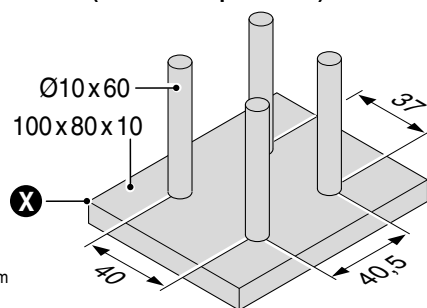

Maße in mm
 Dimensions in mm
 Cotes en mm
 Medidas en mm

5.5

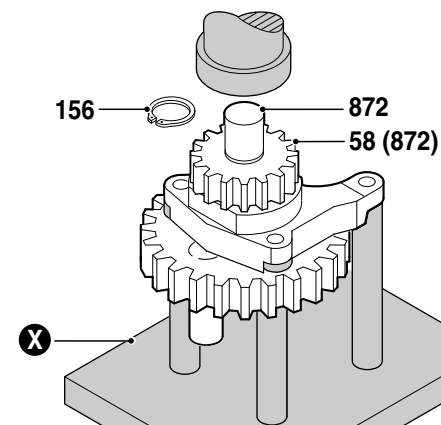

5.6

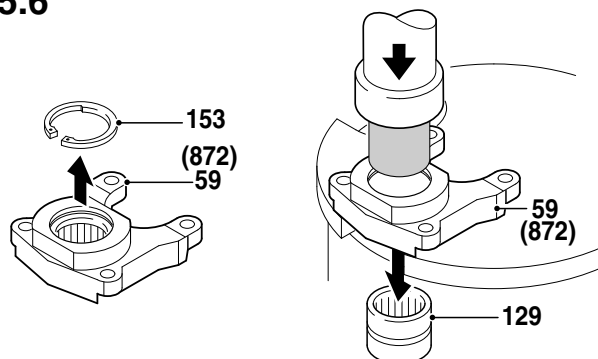

5.7

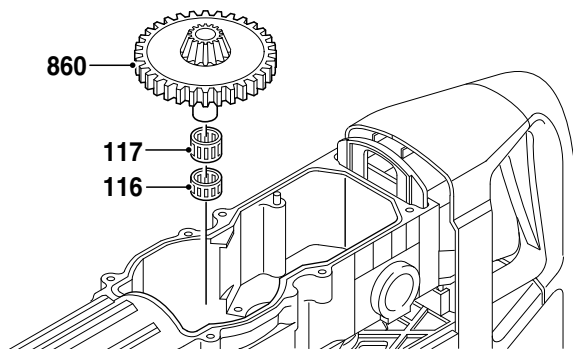

6.

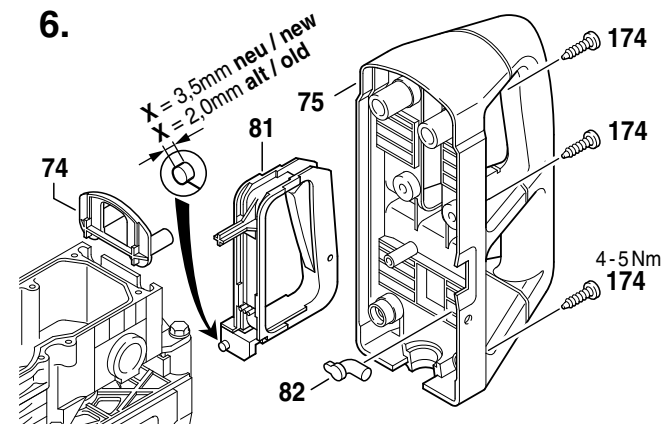

7.

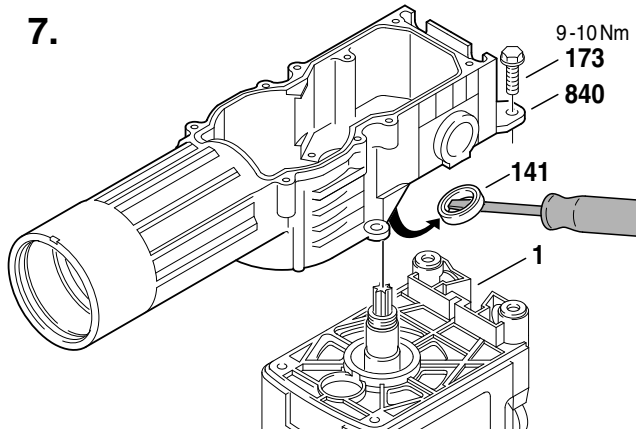

7.1

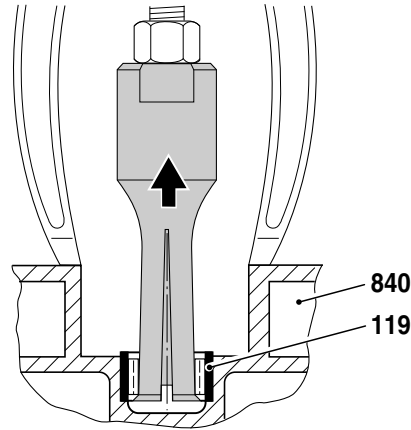

7.2

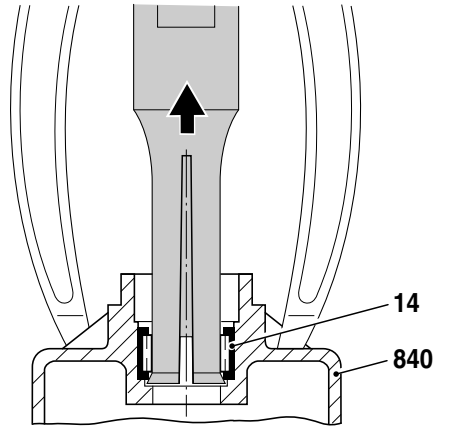

8.

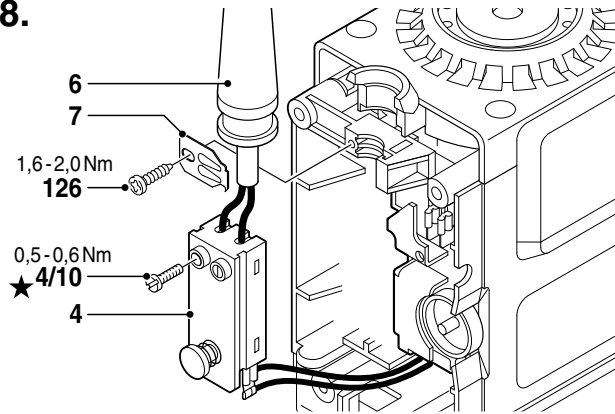

8.1

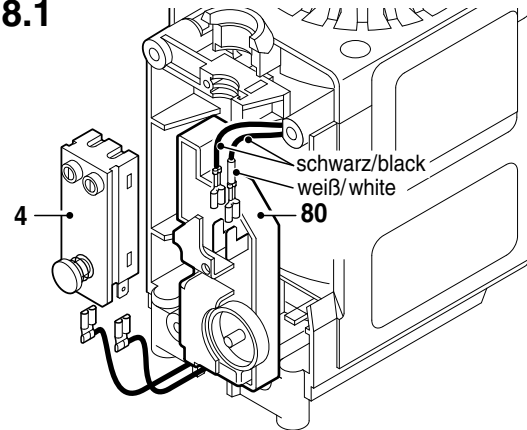

9.

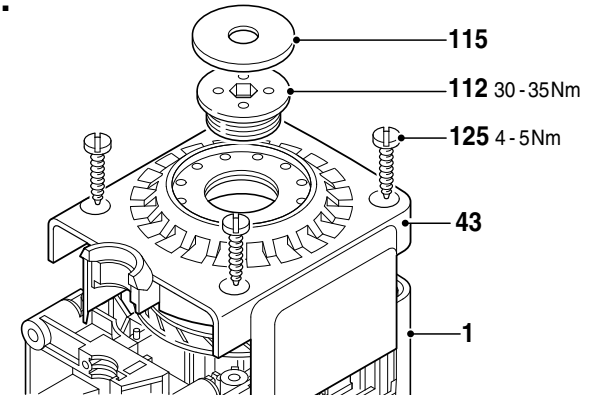

9.1

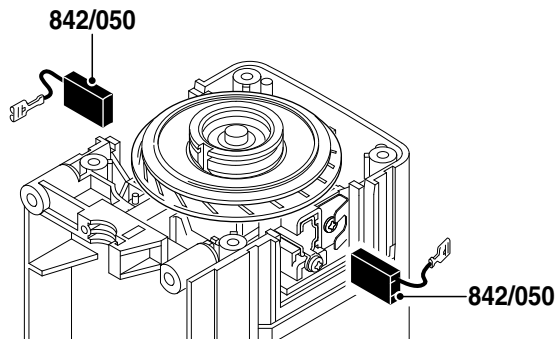

9.2

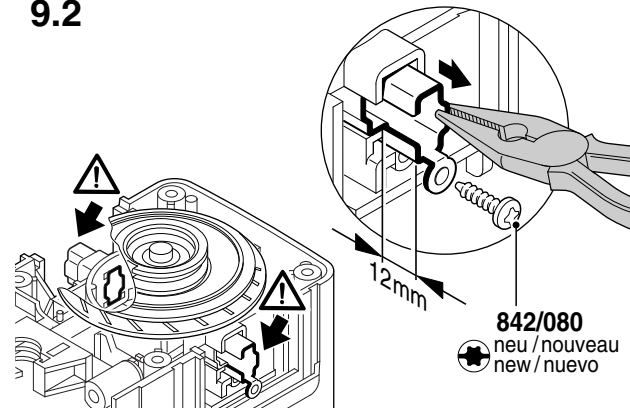

9.3

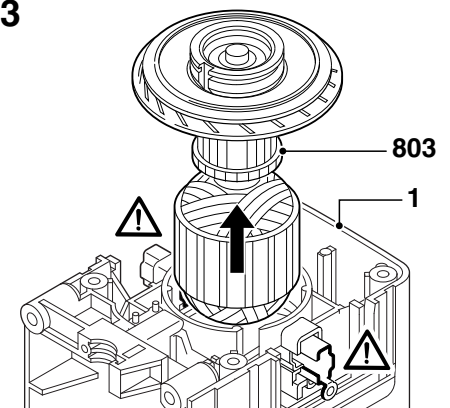

9.5

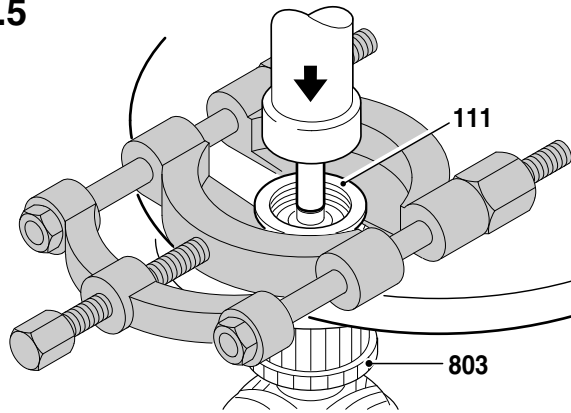

9.6

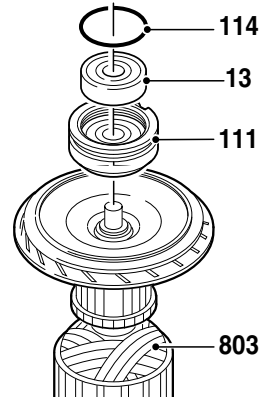

9.7

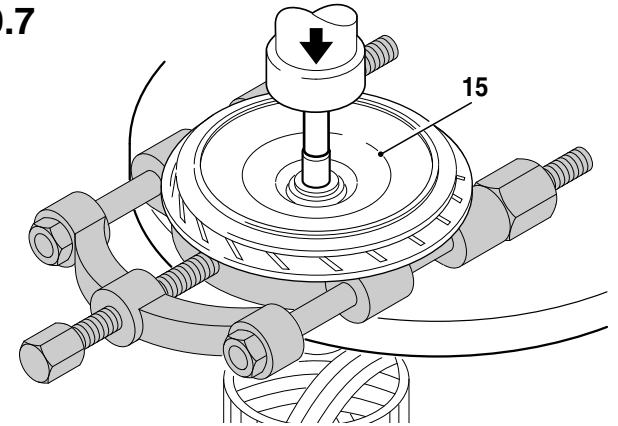

9.8

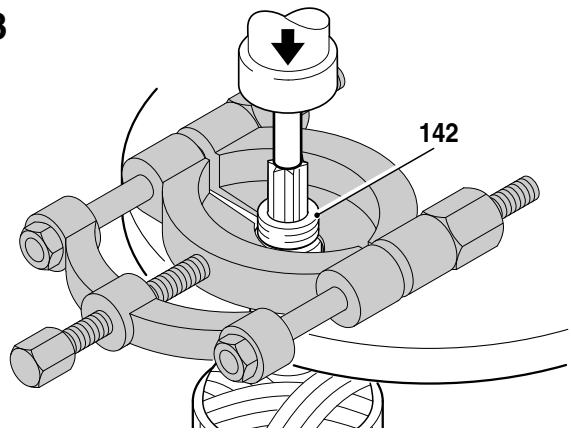

10.

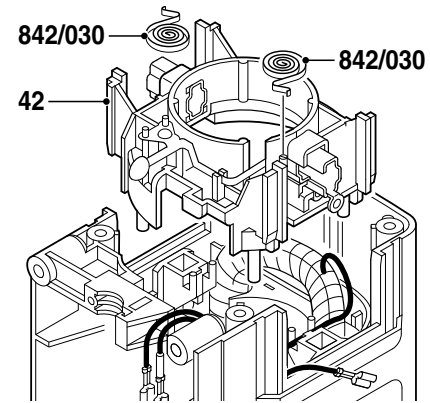

11.

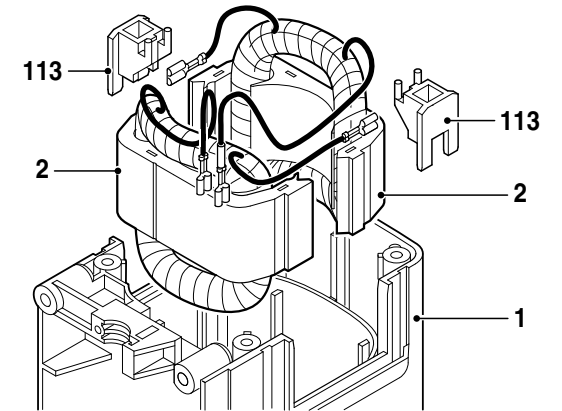

Zusammenbau

Montage nach Explosionszeichnung und diesem Instandsetzungshinweis.

Alle Teile sind gereinigt, abgenutzte und beschädigte Teile werden ersetzt.

Nur Original-Ersatzteile verwenden.

Zähne aller Zahnräder mit Fett **1 615 430 015** bestreichen.

Bitte Schmierhinweise beachten!

Assembly

Assembly using explosion drawings and these repair instructions!

Clean all parts, replace worn-out and damaged parts.

Use only original spare parts!

Grease all gear teeth **1 615 430 015**.

Please note lubrication instructions!

Montage

Le montage s'effectue selon la vue éclatée et les instructions de réparation suivantes.

Toutes les pièces sont nettoyées, les pièces usées ou endommagées doivent être remplacées par des nouvelles. Pour le remplacement de pièces, n'utiliser que des pièces d'origine.

Les dents graisser **1 615 430 015**.

Respecter les instructions de graissage!

Montaje

Realizar el montaje conforme a los dibujos en perspectiva y a estas instrucciones de reparación.

Todas las piezas deben estar limpias. Las piezas desgastadas o dañadas deben reemplazarse por piezas nuevas. Utilizar solamente piezas de repuesto originales.

Dientes engrasar **1 615 430 015**.

Observar las instrucciones de lubricación!

21.

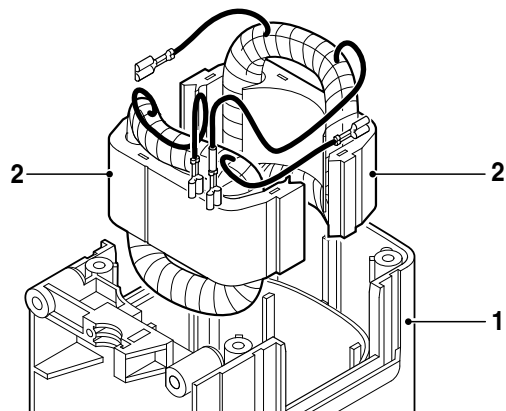

21.1

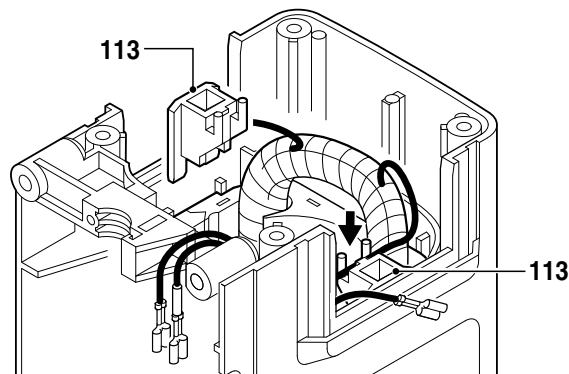

22.

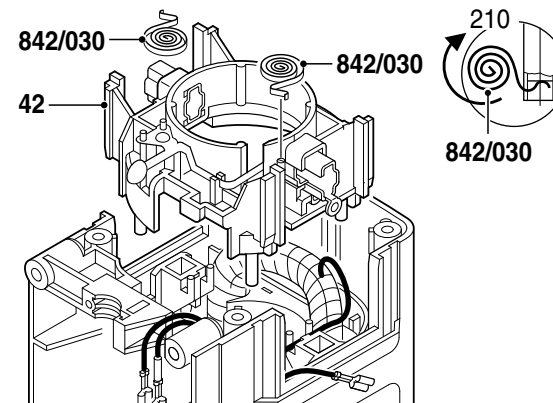

23.

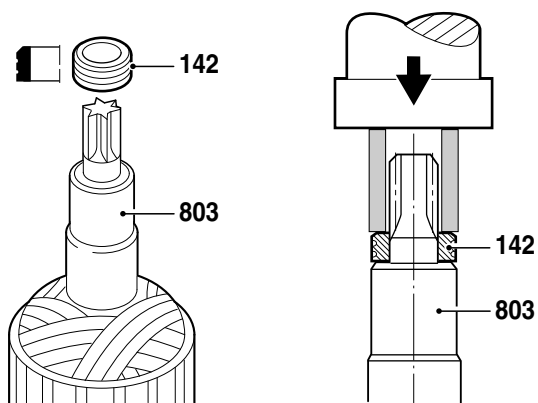

23.1

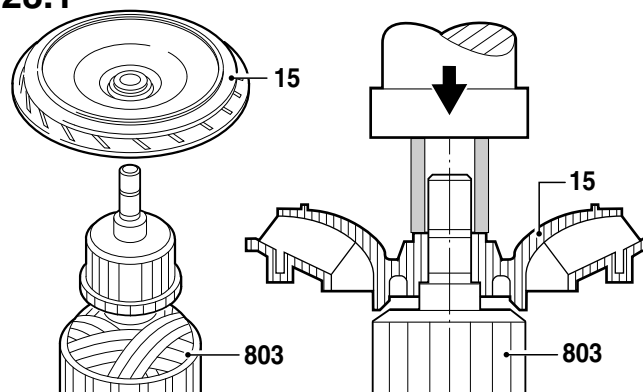

23.2

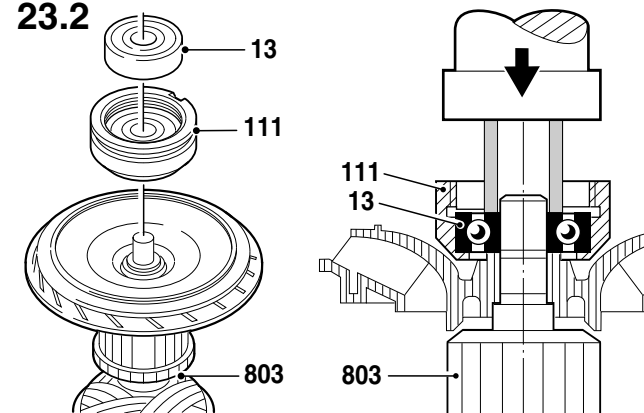

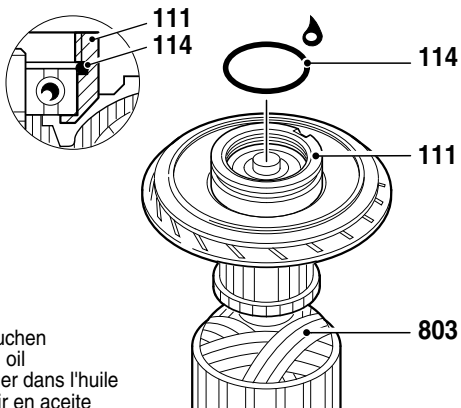
23.3

in Öl tauchen
insert in oil
le plonger dans l'huile
sumergir en aceite

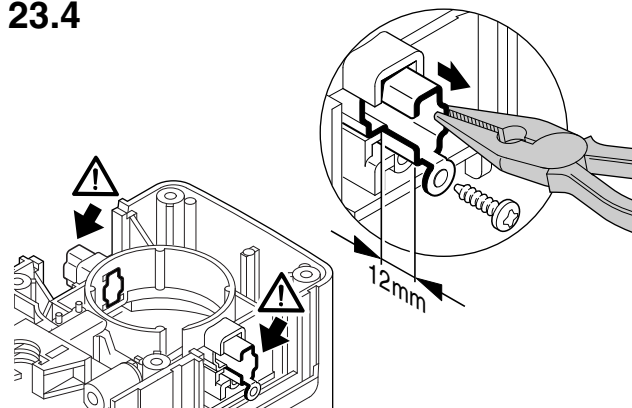
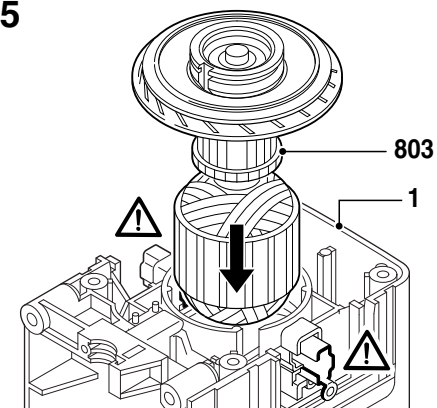
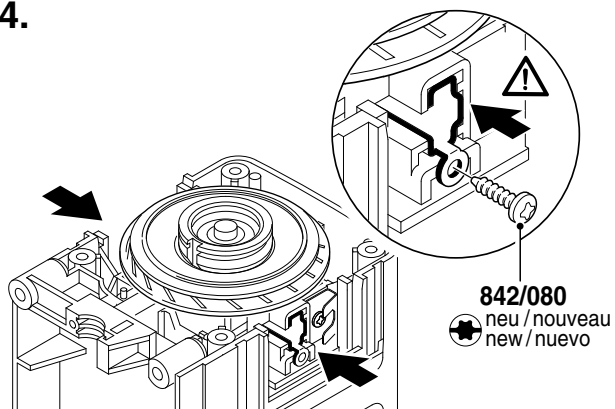
23.4**23.5****24.**

842/080
neu / nouveau
new / nuevo

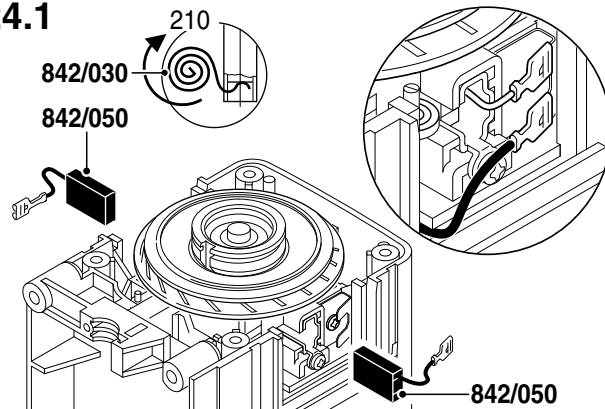
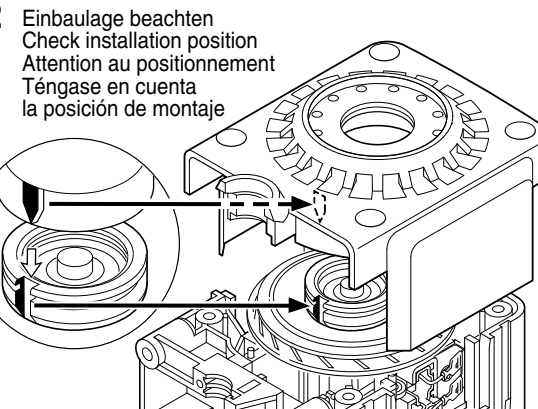
24.1**24.2**

Einbaulage beachten
Check installation position
Attention au positionnement
Téngase en cuenta
la posición de montaje

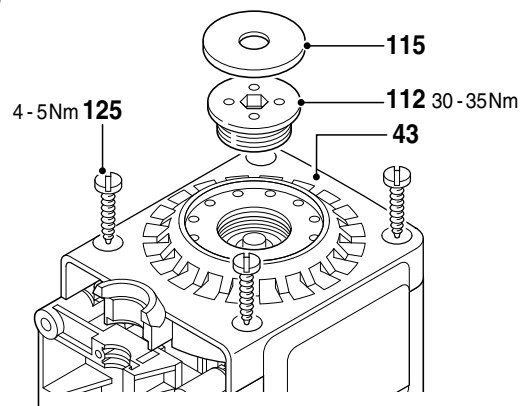
24.3

4-5Nm 125

112 30-35Nm

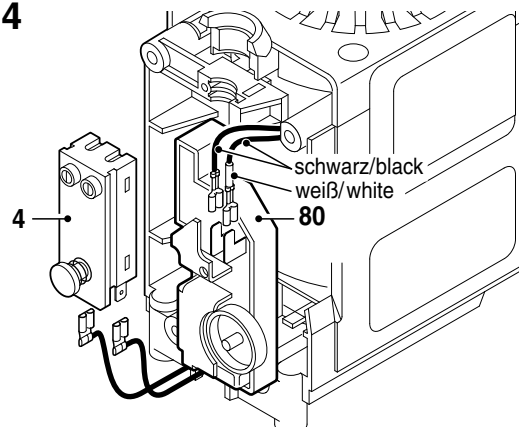
24.4

schwarz/black
weiß/white

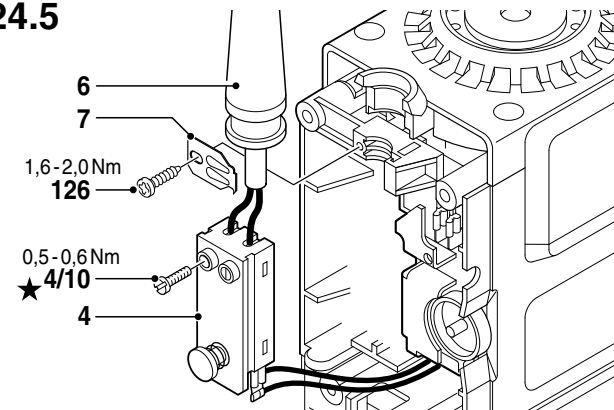
24.5

1,6-2,0Nm
126

0,5-0,6Nm
★ 4/10

25.

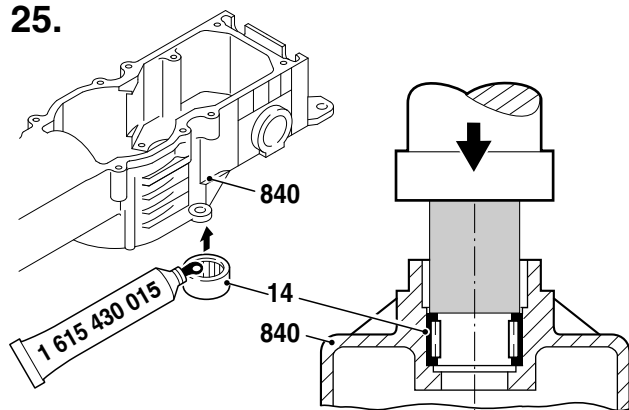

25.1

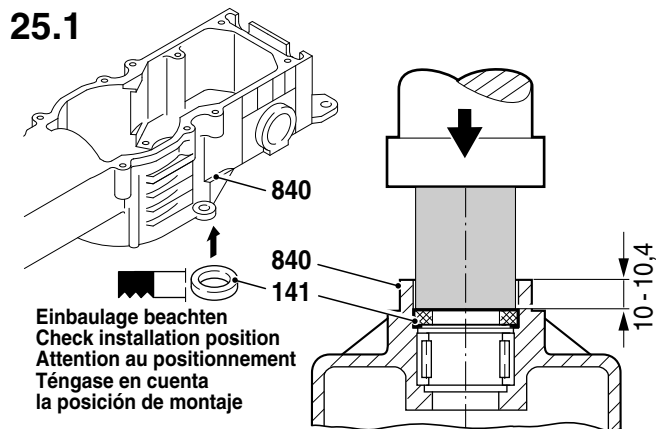

25.2

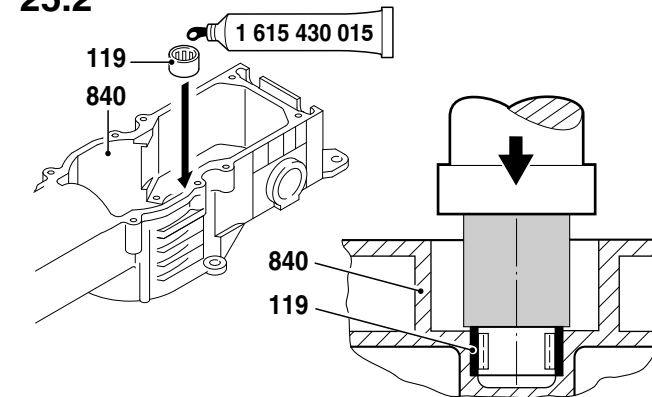

25.3

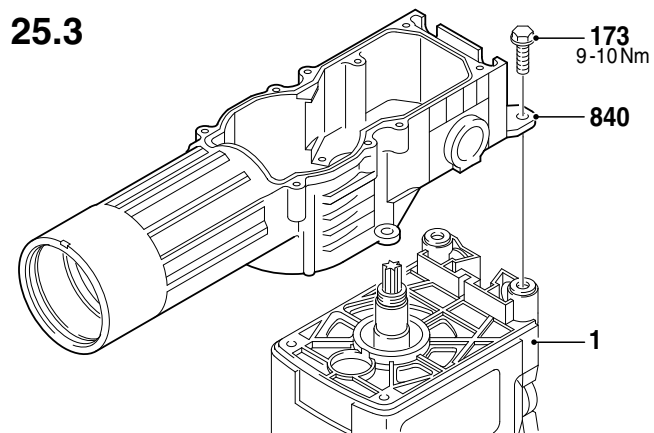

26.

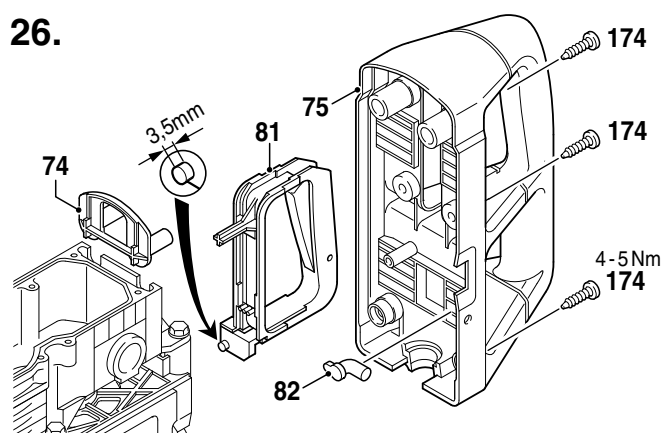

27.

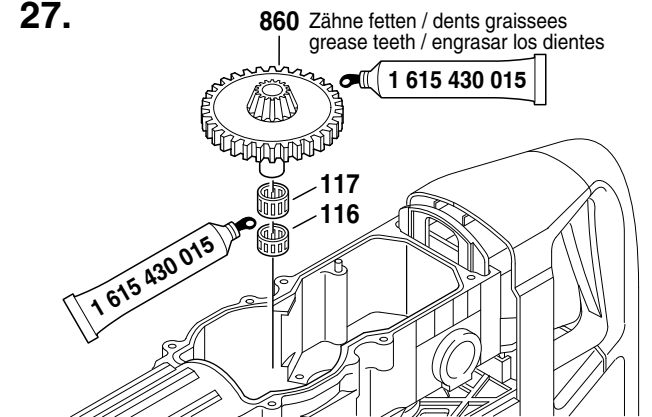

27.1

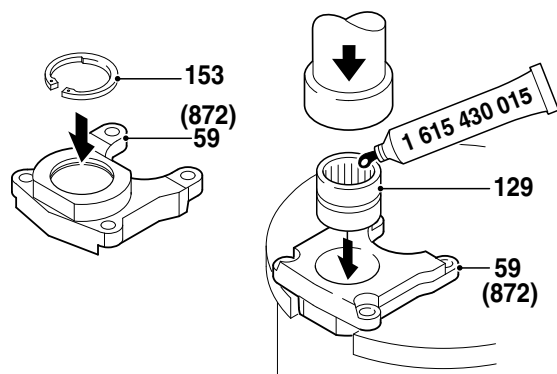

27.2

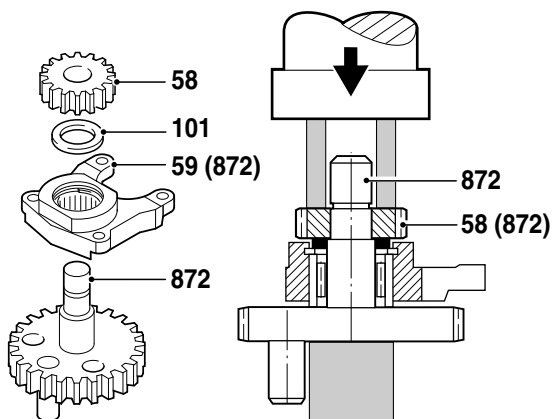

27.3

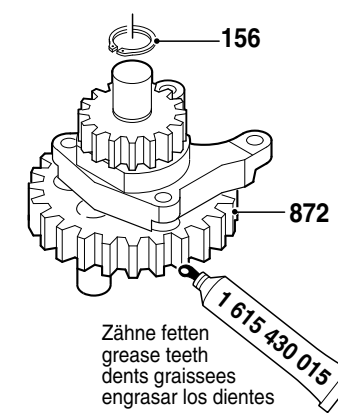

Zähne fetten
grease teeth
dents graissées
engrasar los dientes

27.4

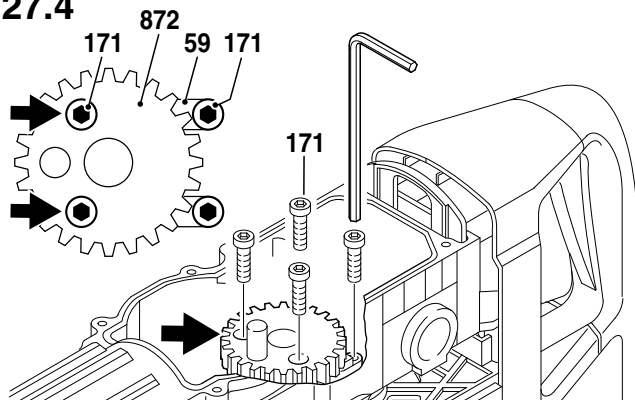

28.

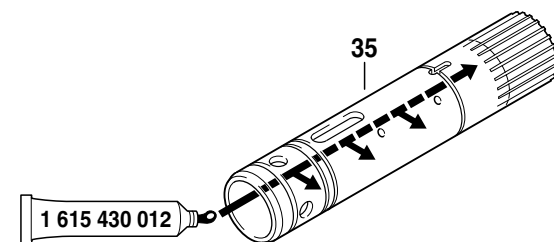

Gleitflächen einstreichen
 Lubricate sliding surfaces
 Enduire les parties mouvantes
 engrasar las piezas móviles

28.1

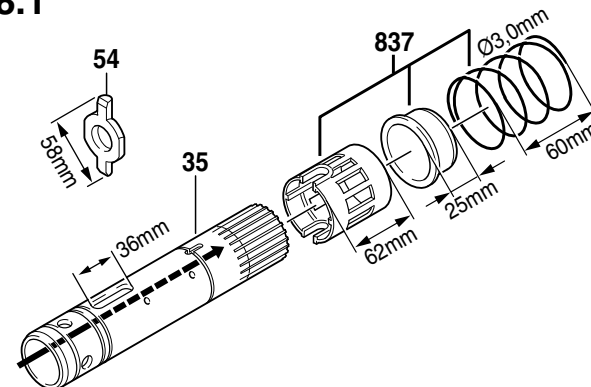

28.2

Einbaulage beachten
 Check installation position
 Attention au positionnement
 Téngase en cuenta
 la posición de montaje

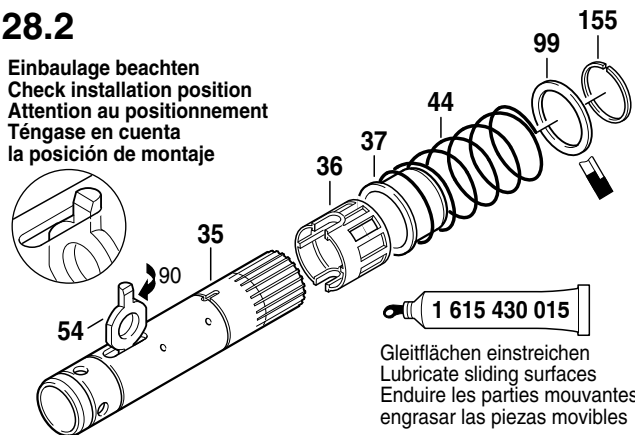

Gleitflächen einstreichen
 Lubricate sliding surfaces
 Enduire les parties mouvantes
 engrasar las piezas móviles

28.3

in Öl tauchen
 insert in oil
 le plonger dans l'huile
 sumergir en aceite

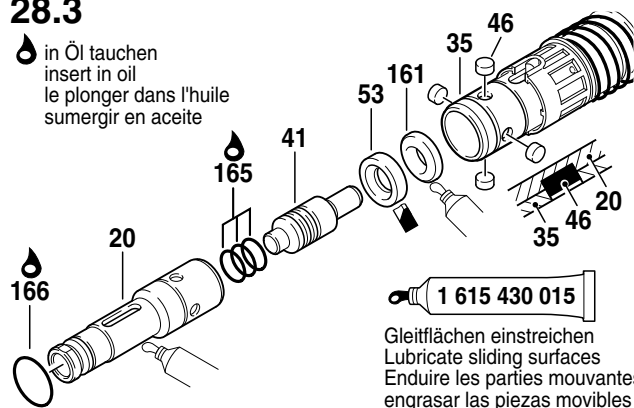

Gleitflächen einstreichen
 Lubricate sliding surfaces
 Enduire les parties mouvantes
 engrasar las piezas móviles

28.4

fetten
 graisser
 grease
 engrasar

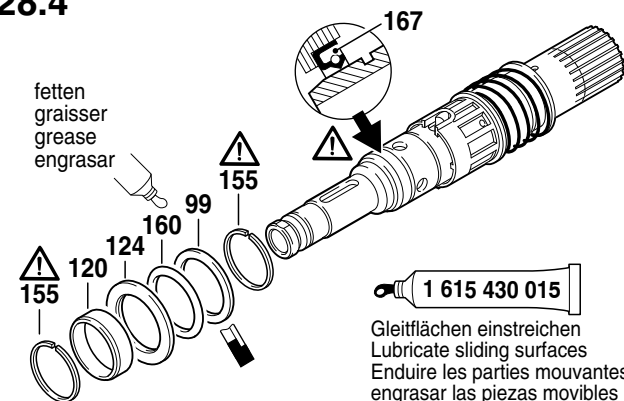

Gleitflächen einstreichen
 Lubricate sliding surfaces
 Enduire les parties mouvantes
 engrasar las piezas móviles

28.5

in Öl tauchen
 insert in oil
 le plonger dans l'huile
 sumergir en aceite

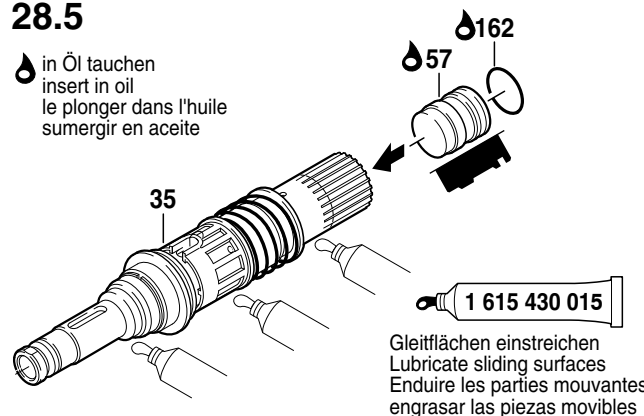

Gleitflächen einstreichen
 Lubricate sliding surfaces
 Enduire les parties mouvantes
 engrasar las piezas móviles

28.6

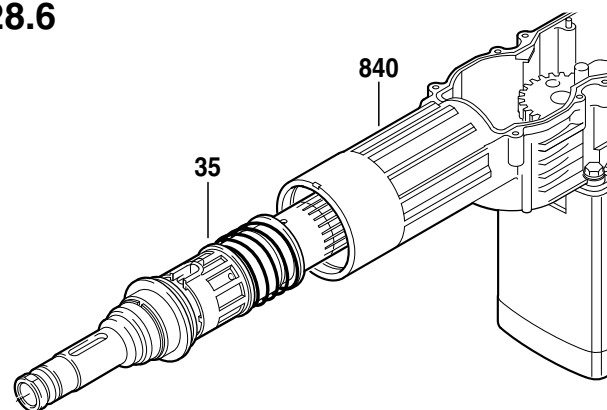

28.7

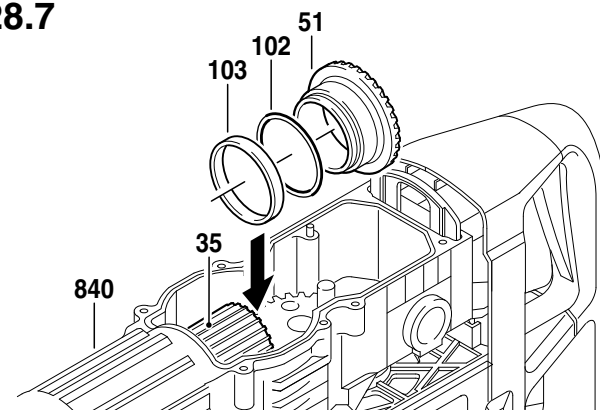

28.8

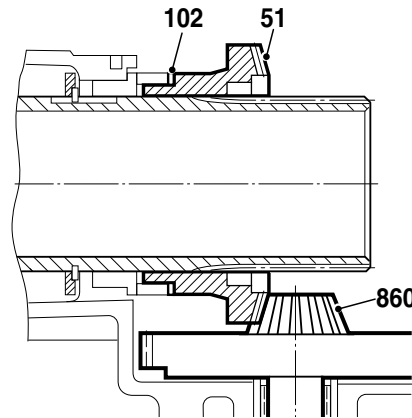
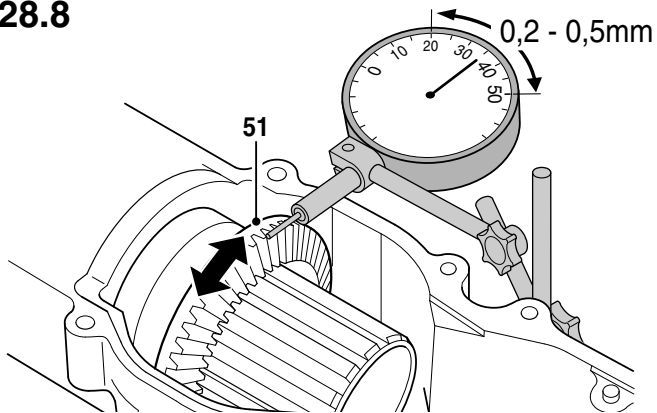

Zahnspiel **fettfrei** messen!
Ausgleich mit Pos. 102.

Measure gear play **grease free!**
Compensate with pos. 102.

Mesurer le jeu des dents **sans qu'il y ait de graisse!**
Compensation avec pos. 102.

Medir el juego entre dientes **sin haber aplicado grasa!**
El reglaje se realiza con pos. 102.

29.

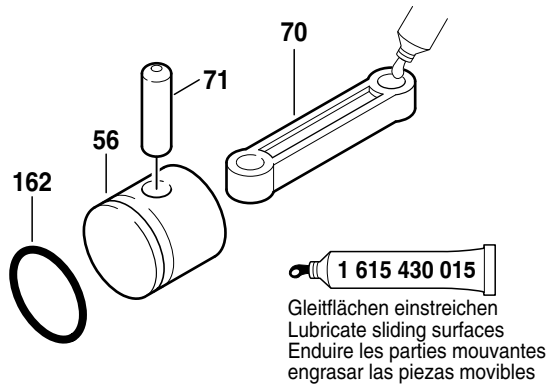

29.1

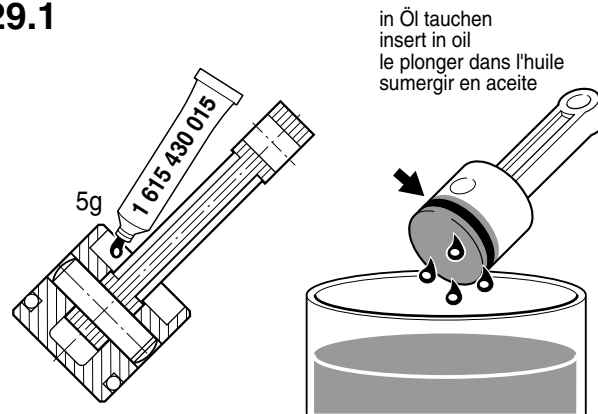

29.2

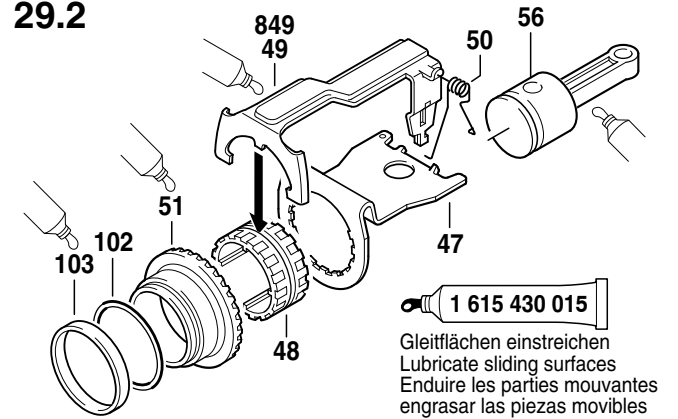

29.3

Einbaulage beachten / Check installation position
Attention au positionnement / Téngase en cuenta
la posición de montaje

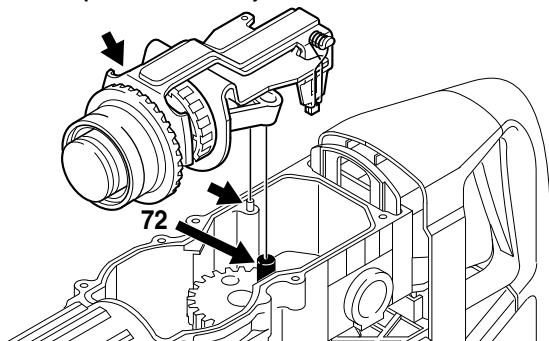

29.4

Pos. 35, 56, 57, 70 fetten (40g);
Rest in Getrieberaum Pos. 840.
Grease the parts pos. 35, 56, 57, 70 (40g);
rest into gear compartment pos. 840.
Graisser les pieces pos. 35, 56, 57, 70 (40g); la
graisse restante dans le compartiment d'engrenage 840.
Engrasar las piezas pos. 35, 56, 57, 70 (40g);
resto en el compartimento del engranaje pos. 840.

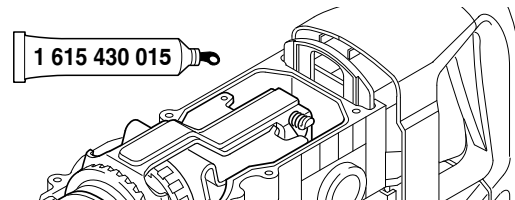

29.5

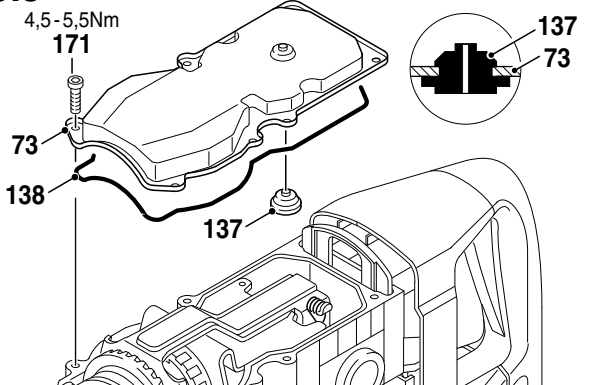

30.

in Öl tauchen
insert in oil
le plonger dans l'huile
sumergir en aceite

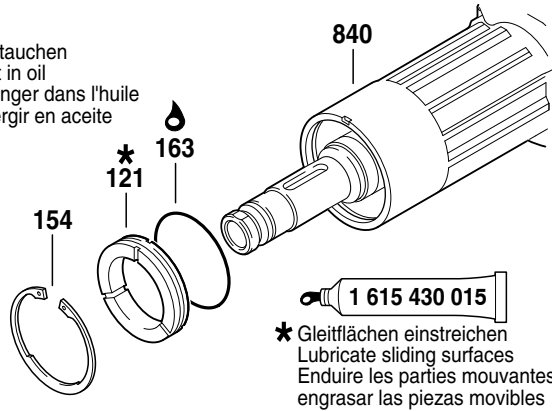

*** Gleitflächen einstreichen**
Lubricate sliding surfaces
Enduire les parties mouvantes
engrasar las piezas movibles

30.1

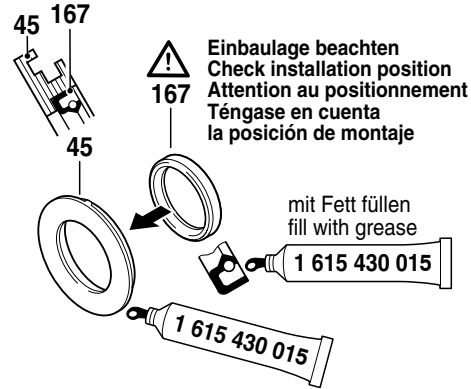

Einbauage beachten
Check installation position
Attention au positionnement
Téngase en cuenta
la posición de montaje

mit Fett füllen
fill with grease

30.2

in Öl tauchen
insert in oil
le plonger dans l'huile
sumergir en aceite

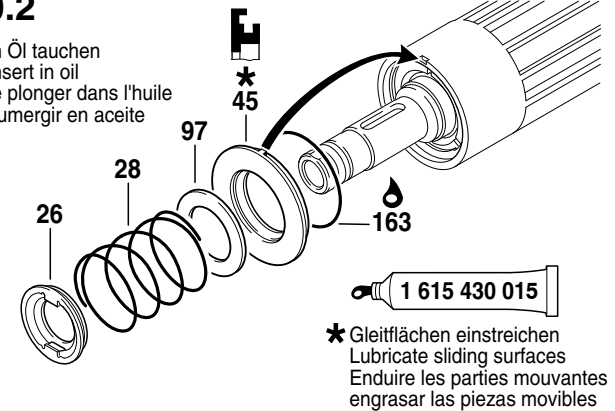

*** Gleitflächen einstreichen**
Lubricate sliding surfaces
Enduire les parties mouvantes
engrasar las piezas movibles

30.3

Nase fetten / grease nose
graisser nez / engrasar nesar

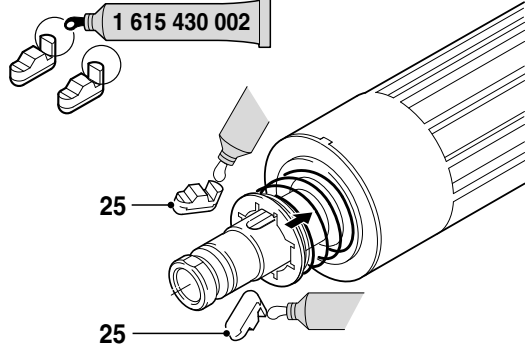

30.4

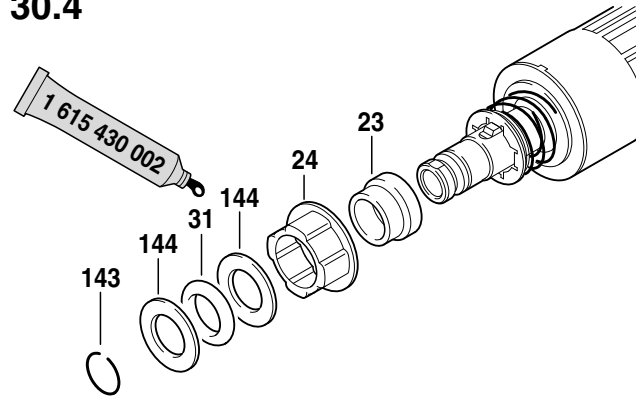

31.

Einbauage beachten
Check installation position
Attention au positionnement
Téngase en cuenta
la posición de montaje

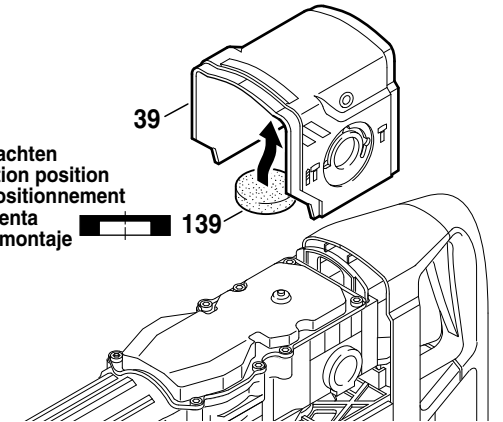

31.1

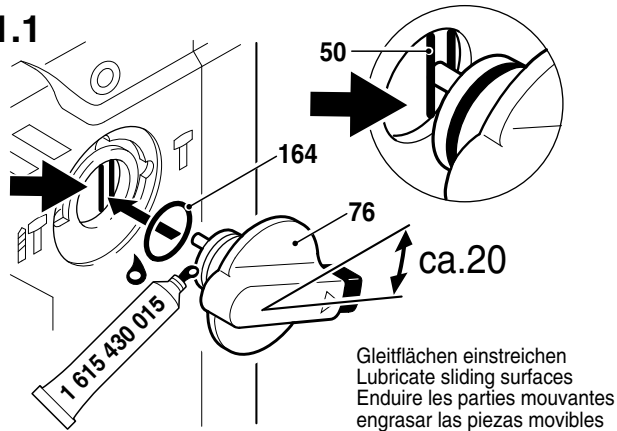

Gleitflächen einstreichen
Lubricate sliding surfaces
Enduire les parties mouvantes
engrasar las piezas movibles

31.2

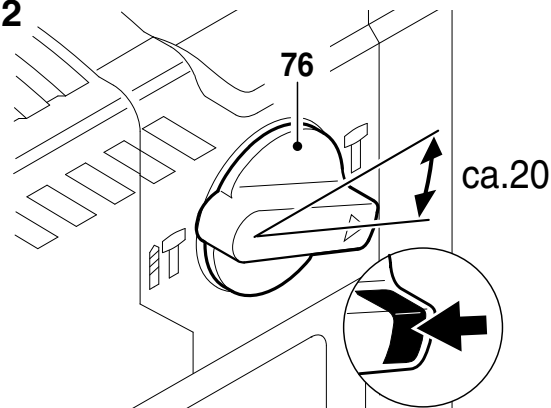

31.3

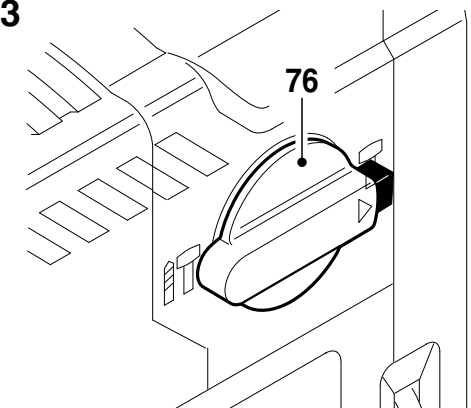

32.

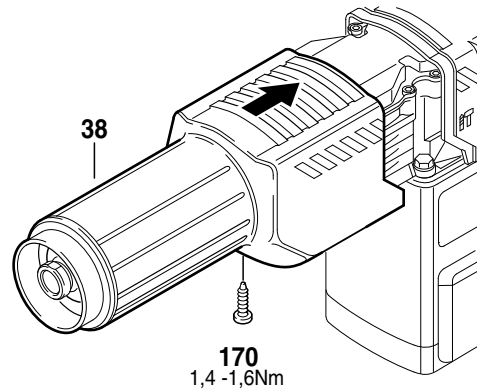

32.1

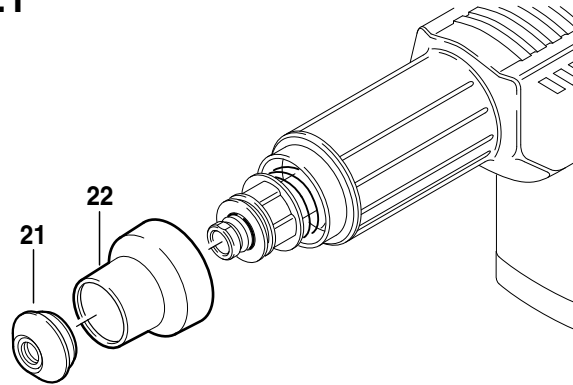

33.

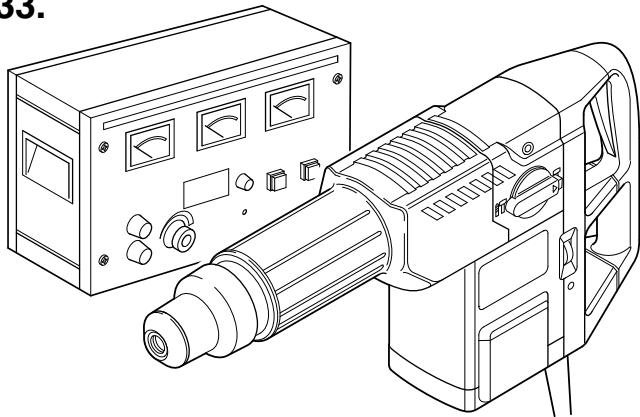

30. Hochspannungsprüfung durchführen.
Beachten:
Die Sicherheitsvorschriften nach DIN, VDE, CEE, AFNOR und weitere in den einzelnen Ländern gültigen Vorschriften sind einzuhalten.
30. Carry out power supply check.
Attention:
Safety regulations according to DIN, VDE, CEE, AFNOR and further regulations applicable in individual countries must be observed.

30. Effectuer un contrôle à haute tension.
Attention:
Respecter les instructions de sécurité selon DIN, VDE, CEE, AFNOR et les autres instructions valables dans les pays respectifs.
30. Efectuar la prueba de alta tensión.
Atención:
Atenerse a las prescripciones de seguridad según DIN, VDE, CEE, AFNOR y a las prescripciones adicionales específicas que pudieran existir en los respectivos países.

34.

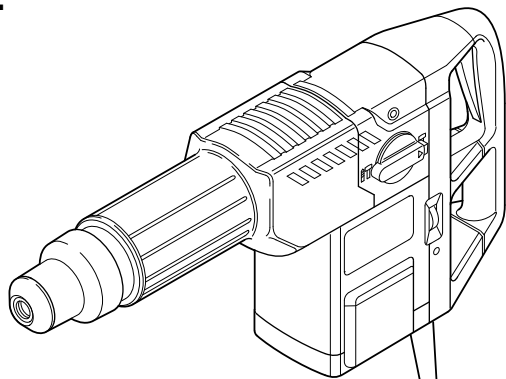

31. Probelauf, Schlagtest, elektrische und mechanische Prüfung durchführen.
31. Perform test run, impact test, electrical and mechanical check-up.

31. Marche à titre d'essai, contrôle de frappe et depercage, effectuer un contrôle mécanique et électrique.
31. Realizar un control funcional, una prueba de taladrado con y sin percusión y los ensayos eléctricos y mecánicos correspondientes.

Änderungen vorbehalten
 Modifications reserved
 Modifications réservées
 Salvo modificaciones

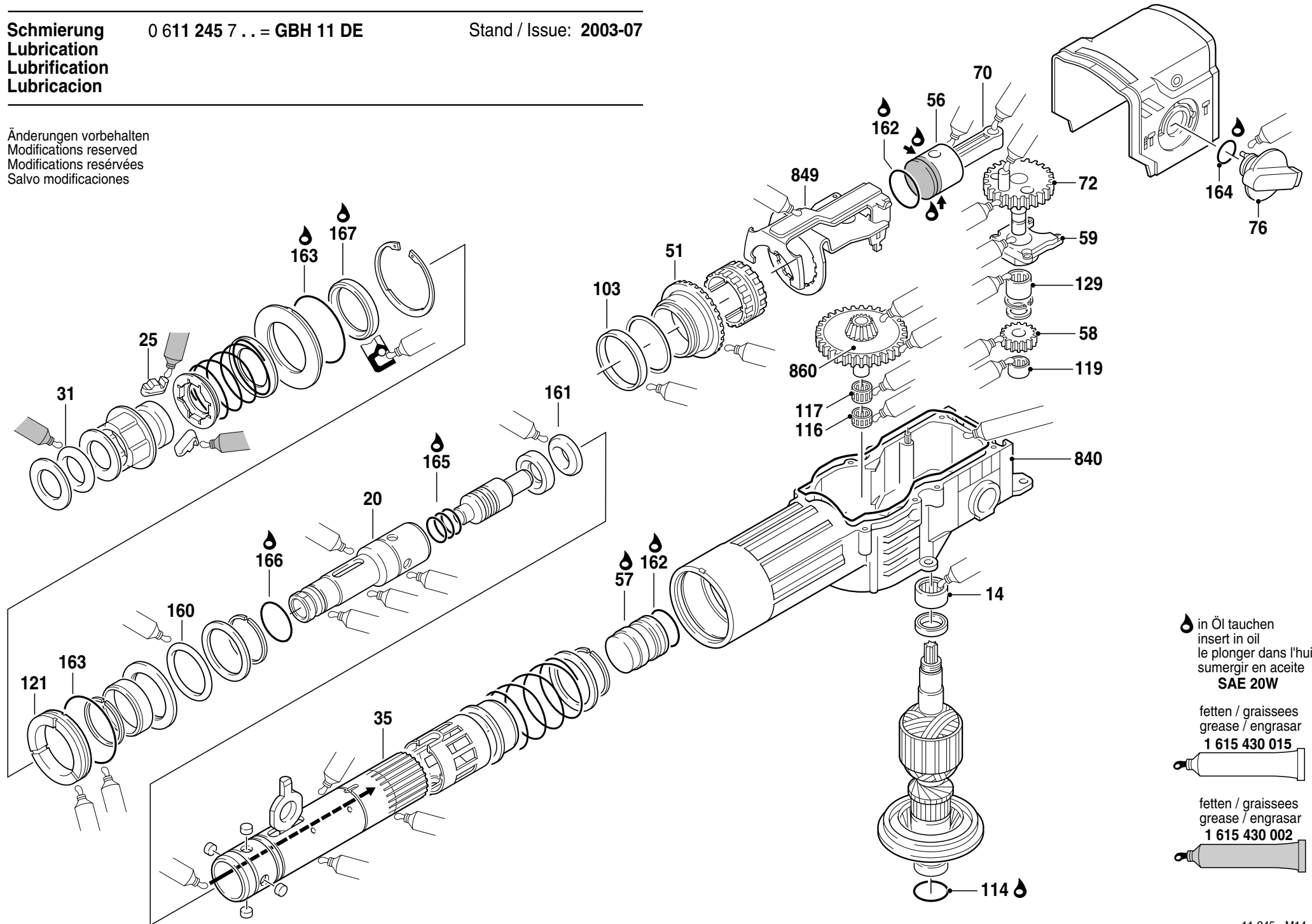

 in Öl tauchen
 insert in oil
 le plonger dans l'huile
 sumergir en aceite
SAE 20W

fetten / graiseses
 grease / engrasar
1 615 430 015

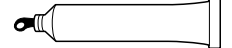

fetten / graiseses
 grease / engrasar
1 615 430 002



**Schmierung
Lubrication
Lubrification
Lubricacion**

0 611 245 7 .. = GBH 11 DE

Stand / Issue: 2003-07

Änderungen vorbehalten
Modifications reserved
Modifications réservées
Salvo modificaciones

Schmierstelle Lubrication point Point de lubrification Punto de lubricacion	Fig./Pos.	Schmierstoff Fett Öl Lubricant grease oil Lubrifiant graisse huile Lubricante grasa aceite	Mengen Quantity Quantite Cantidad	Schmiervorschrift Lubricating instructions Indications de graissage Instrucciones de lubricacion
Getriebe und Schlagwerkraum Gear and percussion mechanism space Carter de l' engrenage et boitier du systeme de frappe Engranaje y parte de engranaje	840 35 56 57 70	1 615 430 015	40 g	Teile fetten, Rest in Getrieberaum 840 grease the parts, rest into gear compartment 840 graisser les pieces, la graisse restante dans le compartiment d'engrenage engrasar las piezas, resto en el compartimento del engranaje 840
Werkzeughalter Tool holder Porte outil Portaherramientas	20			fetten grease graisser engrasar
Hammerrohr Hammer pipe Tube de marteau Tubo de martillo	35		17g	Teile fetten grease the parts graisser les pieces engrasar las piezas
Schaltgabel Control fork Fourchette de commande Horquilla de mando	849			fetten grease graisser engrasar
Hammerkolben Hammer piston Piston de marteau Embolo de martillo	56 70		5g	fetten, Hohlraum füllen grease, fill cavity graisser, cavite remplir engrasar, llenar el vacio
Kupplung Clutch Accouplement Acoplamiento	860		4g	Teile fetten, Rest einfüllen grease the parts, fillin the rest graisser les pieces, restante remplir engrasar las piezas, restante llenar
Pleuelstange/Exzenterzapfen Connecting rod Bielle Biela	70 872			fetten / Fettdepot füllen, grease / fill cavity graisser / remplir cavite engrasar / llenar el vacio
Knebelgriff Clamp handle Manette Maneta	76			fetten grease graisser engrasar
Ring Ring Anneau Anillo	121 160 161			fetten grease graisser engrasar

Schmierstelle Lubrication point Point de lubrification Punto de lubricacion	Fig./Pos.	Schmierstoff Fett Öl Lubricant grease oil Lubrifiant graisse huile Lubricante grasa aceite	Mengen Quantity Quantite Cantidad	Schmiervorschrift Lubricating instructions Indications de graissage Instrucciones de lubricacion
Ring Ring Anneau Anillo	31 103	1 615 430 015		fetten grease graisser engrasar
Zahnrad Toothed gear Roue d'engrenage Rueda de engranaje	51 60 872 58			Zähne füllen, fetten Fill teeth, grease remplir les dentes, graisser Llenar dientes, engrasar
Lagerflansch Bearing flange Flasque de palier Brida de cojinete	59			fetten grease graisser engrasar
Nadellager Needle-roller bearing Roulement a aiguilles Rodamiento de agujas	14 116 117;119 129		*	Hohlraum füllen, fetten Fill cavity, grease Remplir cavite, graisser Llenar el vacio, engrasar
Sperrkörper Stopping device Corps d'arret Cuerpo de bloqueo	25	1 615 430 002		Nase fetten grease nose graisser neez engrasar nesar
Wellendichtring Shaft sealing ring Joint a levres Reten para arboles	167			Hohlraum zwischen Dichtlippen füllen fill cavity between sealing lips remplir cavite entre les levres du joint llenar el vacio entre los labios del reten
Hammerkolben Hammer piston Piston de marteau Embolo de martillo	56 162	SAE 20 W Mineralöl, handelsüblich Mineral oil, standard / Huile minerale en vente dans le comerc Aceite usual en el comercio		einölen; in Öl tauchen oil; dip in oil huiler le plonger dans l'huile engrasar con aceiter; sumergir en aceite
Schläger; O-Ring Striker; O-ring Frappeur; joint torique Percutor; antillo toroidal	57+162 114 163;164 165;166			einölen; in Öl tauchen oil; dip in oil huiler le plonger dans l'huile engrasar con aceiter; sumergir en aceite

*sofern Lager ungefettet
if bearing is unlubricated
si roulement n'est pas graisse
en caso de que el rodamiento
esta son grasa

Prüfwerte

0 611 245 7 .. = GBH 11 DE

Stand / Issue: 2003-07

Testing values**Valeurs de vérification****Valores de control**

Spannung Voltage Voltage Voltaje	Leerlauf no-load running marche à vide marcha en vacío		Widerstand (20 C/ 68 F) resistance résistance resistencia		Zulässige Übertemperatur im Leerlauf admissible over temperature at no-load élévation admissible de température à vide sobrettemperatura admisible en vacío		
V Typ	A	Spindeldrehzahl speed of spindle vitesse de la broche velocidad del husillo 1/min - rpm - t/mn - rpm Stufe	des Ankers of rotor du rotor del rotor W	einer Feldspule of one stator coil d'une bobine du stator de una bobina del estator W	Motor motor moteur motor C	Getriebe gear engrenage engrenaje C	Arbeitsspindel spindle broche husillo C
100	0.000 - 0.000	0 - 0 0 - 0	0.196 - 0.280	0.130 - 0.196	5	6	15
110	0.000 - 0.000	0 - 0 0 - 0	0.265 - 0.367	0.189 - 0.271	5	6	15
115	0.000 - 0.000	0 - 0 0 - 0	0.265 - 0.367	0.189 - 0.271	5	6	15
120	0.000 - 0.000	0 - 0 0 - 0	0.265 - 0.367	0.189 - 0.271	5	6	15
230	4.448 - 5.653	6 247 - 275 1 133 - 146	0.875 - 1.135	0.759 - 0.997	5	6	15
240	0.000 - 0.000	0 - 0 0 - 0	0.875 - 1.135	0.759 - 0.997	5	6	15

Bemerkung: Überrastrmoment der Kupplung 18 -34 Nm. Bei nicht erreichen von 18 Nm, Kupplung ersetzen.
For your notice: Slipping point of clutch 18 - 34 Nm. Under 18 Nm replace clutch.

Kollektor-Mindestdurchmesser: mm
Minimum diameter of commutator:
Diamètre minimum du collecteur:
Diámetro mínimo del colector:

Kohlebürsten-Mindestlänge:
Minimum length of brushes:
Longueur minimale des balais:
Longitud mínima de las escobillas:

= X Abschaltkohlen
cut-off brushes
charbon rupteur
carbón de desconexión

Änderungen vorbehalten

Unsere Erzeugnisse werden stets dem neuesten technischen Stand angepaßt. Deshalb müssen wir uns Änderungen von technischen Daten vorbehalten.

Modifications

Our products are constantly modified to meet new technical standards. We therefore reserve the right to alter data and specifications without prior notice.

Modifications

Nos produits sont continuellement adaptés aux dernières nouveautés techniques et les dates sont données sous réserve de changement.

Modificaciones

Nuestros fabricados van siendo adaptados constantemente a las últimas conquistas técnicas. Por ello, tenemos que reservarnos el derecho de introducir modificaciones en los datos técnicos.