

INSTANDSETZUNGSHINWEISE  
REPAIR INSTRUCTIONS  
INSTRUCTIONS DE REPARATION  
INSTRUCCIONES DE REPARACION



**Bohrhammer**                    **Typ 3 611 J04 300 = GBH 18 V-LI**  
**Rotary Hammer**  
**Marteau perforateur**  
**Martillo perforador**

Änderungen vorbehalten. Unsere Erzeugnisse werden stets dem neuesten technischen Stand angepaßt. Deshalb behalten wir uns Änderungen vor.

Modifications. Our products are constantly modified to meet new technical standards. We therefore reserve the right to alter data and specifications without prior notice.

Modifications. Nos produits sont continuellement adaptés aux dernières nouveautés techniques et les dates sont données sous réserve de changement.

Modificaciones. Nuestros fabricados van siendo adaptos constantemente a las últimas conquistas técnicas. Por ello, tenemos que reservarnos el derecho de introducir modificaciones en los datos técnicos.

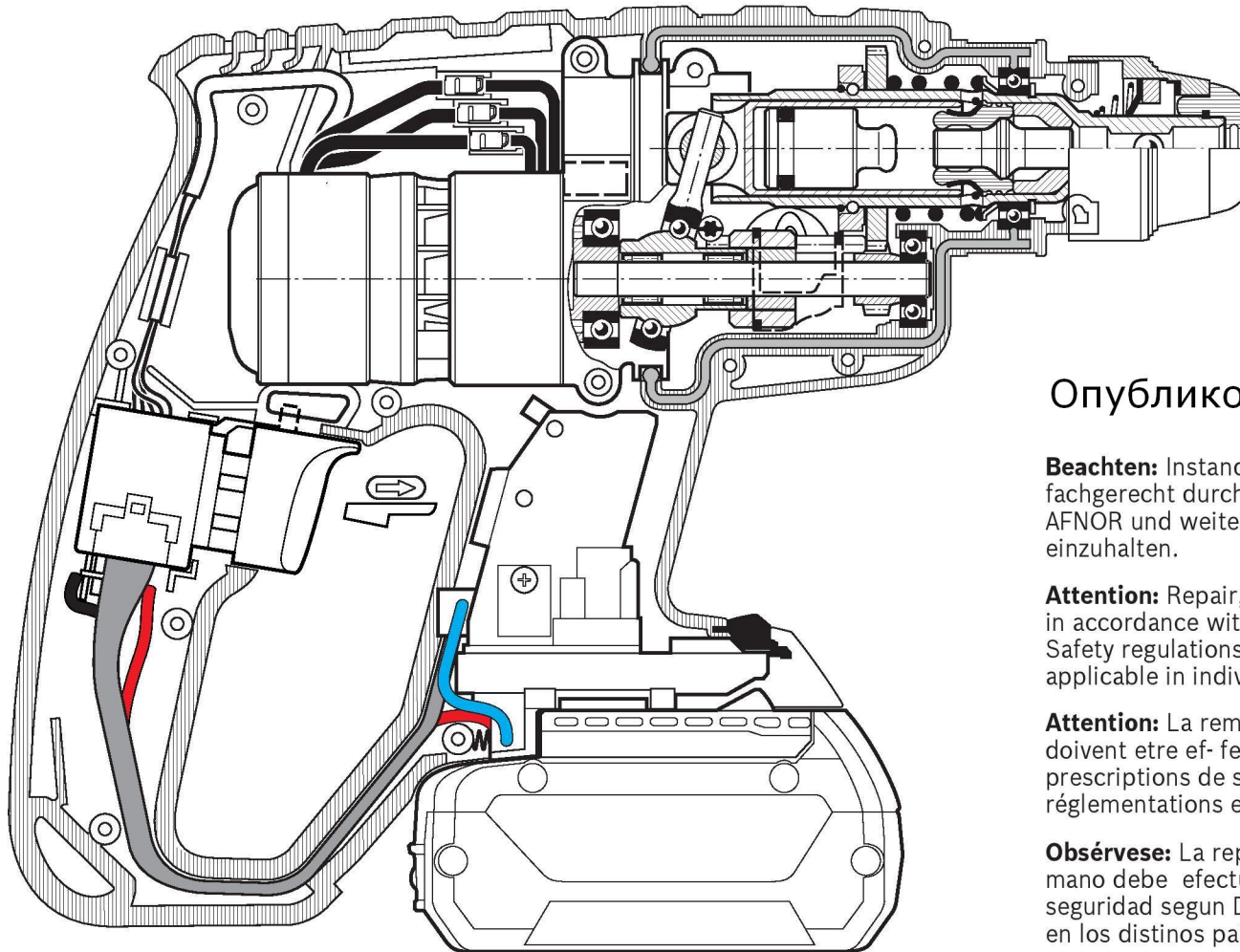

Опубликовано на сайте [www.rem-5.ru](http://www.rem-5.ru)

**Beachten:** Instandsetzung, Änderung und Prüfung von Elektrowerkzeugen sind fachgerecht durchzuführen. Die Sicherheitsvorschriften nach DIN, VDE, CEE, AFNOR und weitere in den einzelnen Ländern gültigen Vorschriften sind einzuhalten.

**Attention:** Repair, modification, and testing of power tools must be carried out in accordance with the generally recognised principles of engineering practise. Safety regulations according to DIN, VDE, CEE, AFNOR and further regulations applicable in individual countries must be observed.

**Attention:** La remise en état, la modification et le controle des outils électriques doivent être effectués par des personnes qualifiées. Il convient de respecter les prescriptions de sécurité selon DIN, VDE, CEE, AFNOR, ainsi que les réglementations en vigueur dans le pays concerné.

**Obsérvese:** La reparación, modificación y verificación de herramientas eléctricas mano debe efectuarse en forma técnicamente correcta. Respetar las normas de seguridad según DIN, VDE, CEE, AFNOR, así como otras disposiciones vigentes en los distintos países.

## Zerlegen

Für die Demontage werden handelsübliche Werkzeuge benötigt.

1. Eingangsprüfung durchführen.  
**Beachten:**  
Die Sicherheitsvorschriften nach DIN, VDE, CEE, AFNOR und weitere in den einzelnen Ländern gültigen Vorschriften sind einzuhalten.
2. Zerlegen nach Explosions-, Schnittzeichnung und diesem Instandsetzungshinweis.

## Disassembly

Use normal trade tools by disassembly.

1. Carry out power supply check.  
**Attention:**  
Safety regulations according to DIN, VDE, CEE, AFNOR and further regulations applicable in individual countries must be observed.
2. Disassembly using explosion, cut-away drawings and these repair instructions!

## Démontage

Pour le démontage, des outils en usage dans le commerce sont nécessaires.

1. Effectuer un contrôle préliminaire.  
**Attention:**  
Respecter les instructions de sécurité selon DIN, VDE, CEE, AFNOR et les autres instructions valables dans les pays respectifs.
2. Démontez l'appareil suivant la vue éclatée, le plan en coupe et ces instructions de réparation.

## Desmontaje

Para el desmontaje no se precisan herramientas especiales.

1. Realizar control de recepción.  
**Atención:**  
Atenerse a las prescripciones de seguridad según DIN, VDE, CEE, AFNOR y a las prescripciones adicionales específicas que pudieran existir en los respectivos países.
2. Realizar el desmontaje conforme a los dibujos en perspectiva y en sección, y a estas instrucciones de reparación.

1.

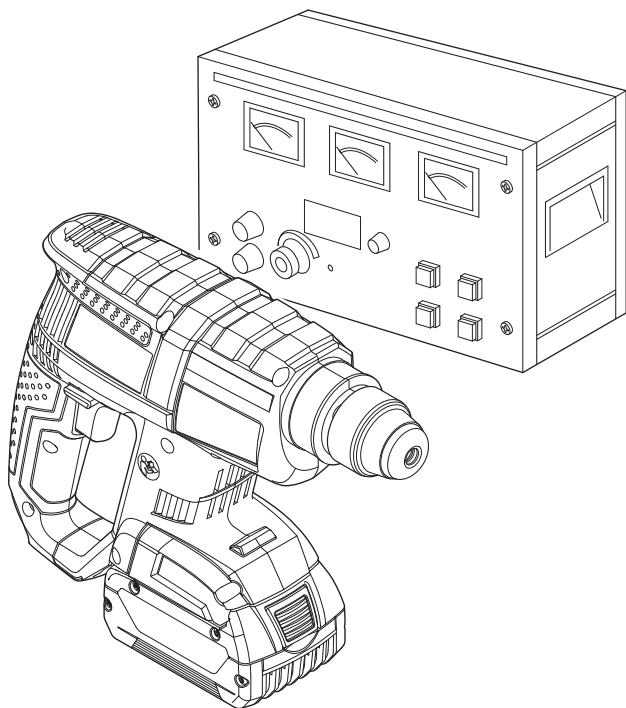

2.

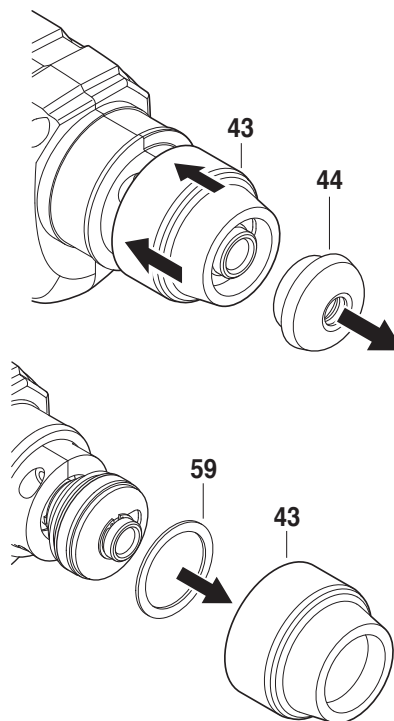

2.1

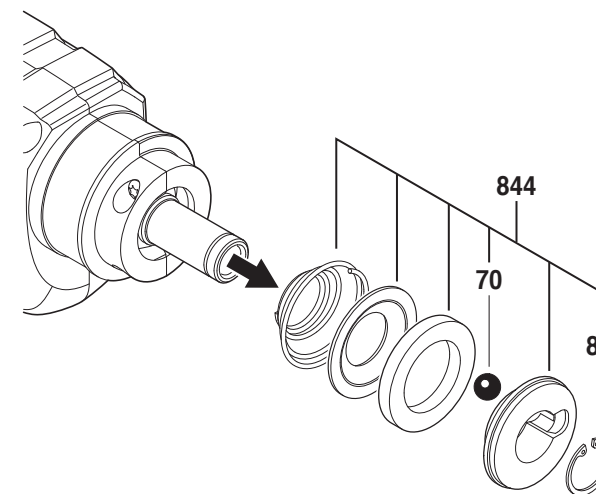

3.

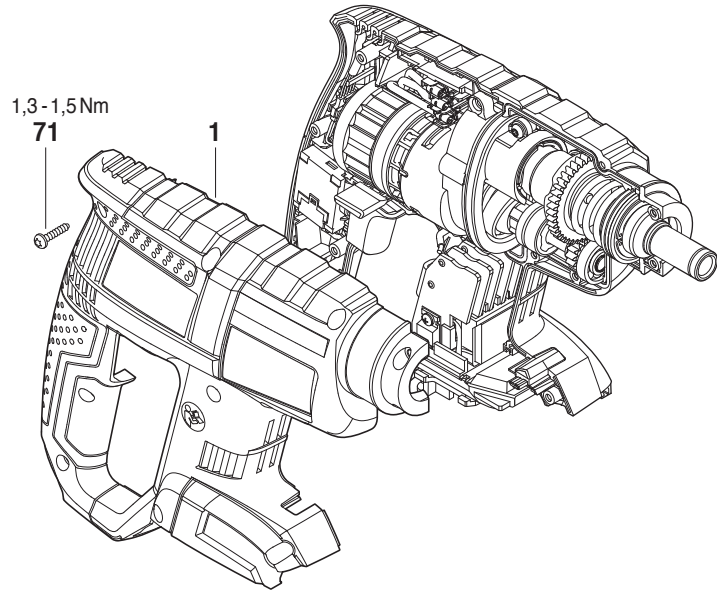

5.

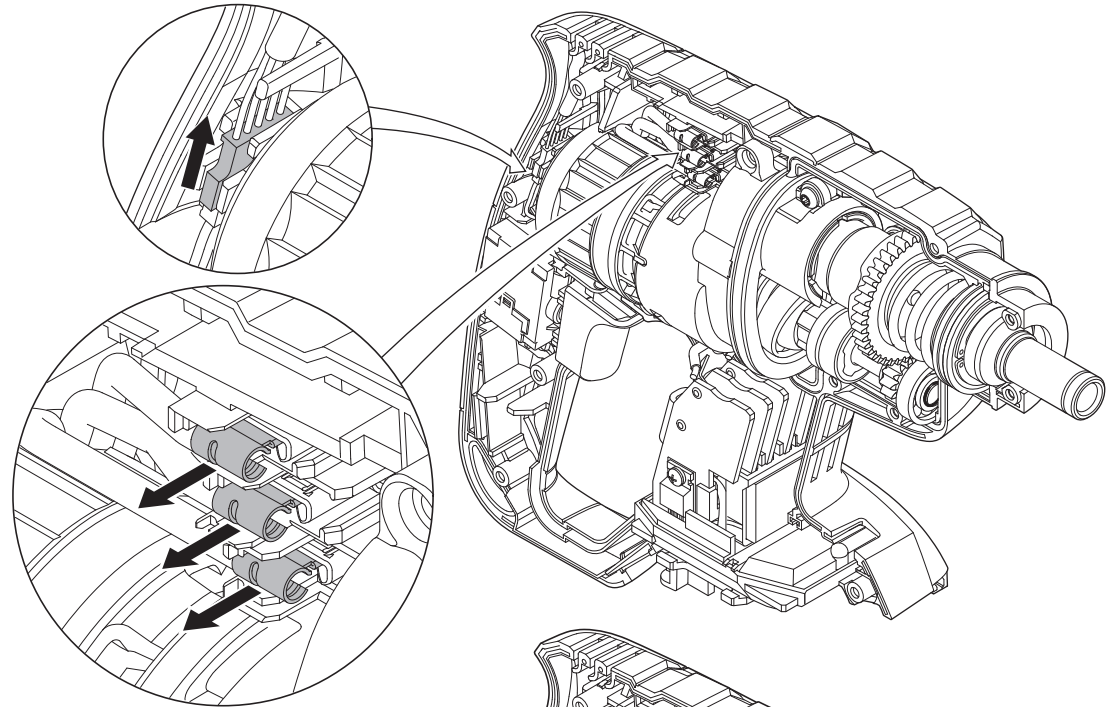

4.

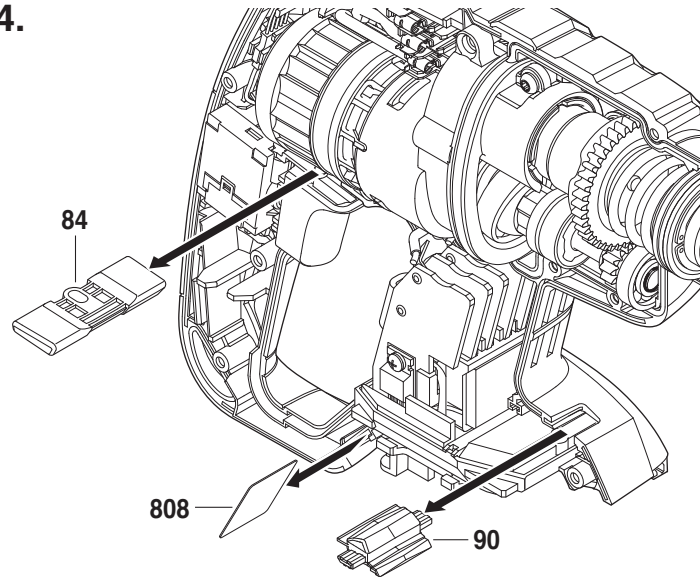

6.

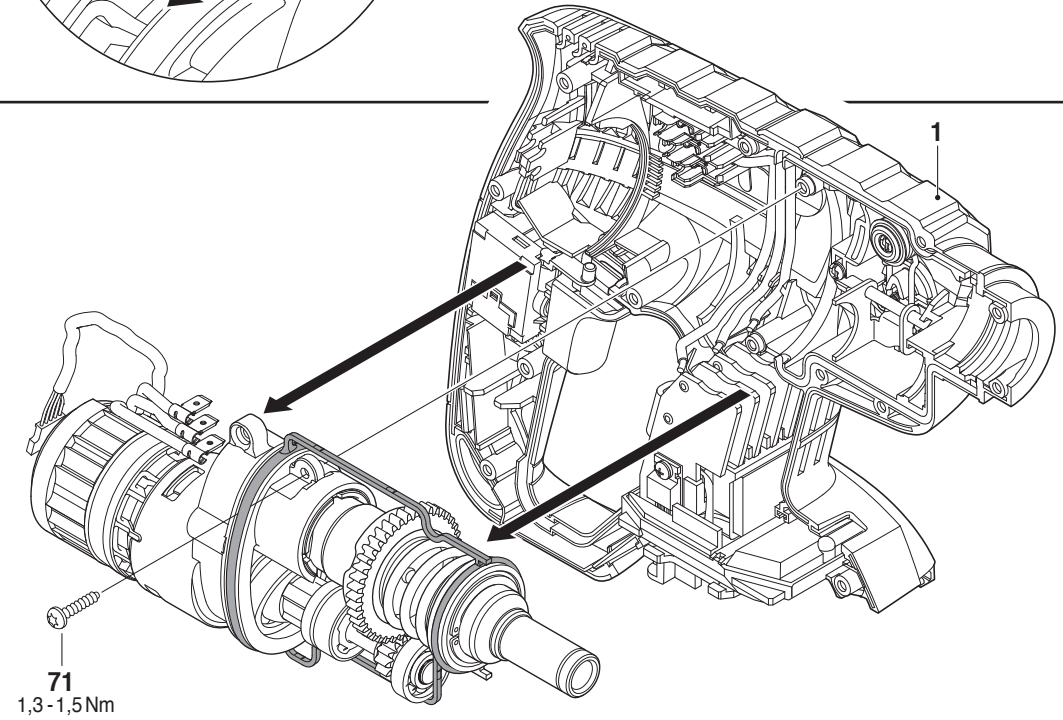



7.

blau / blue  
bleu / azul  
grün / green  
vert / verde  
rot / red  
rouge / rojo

4

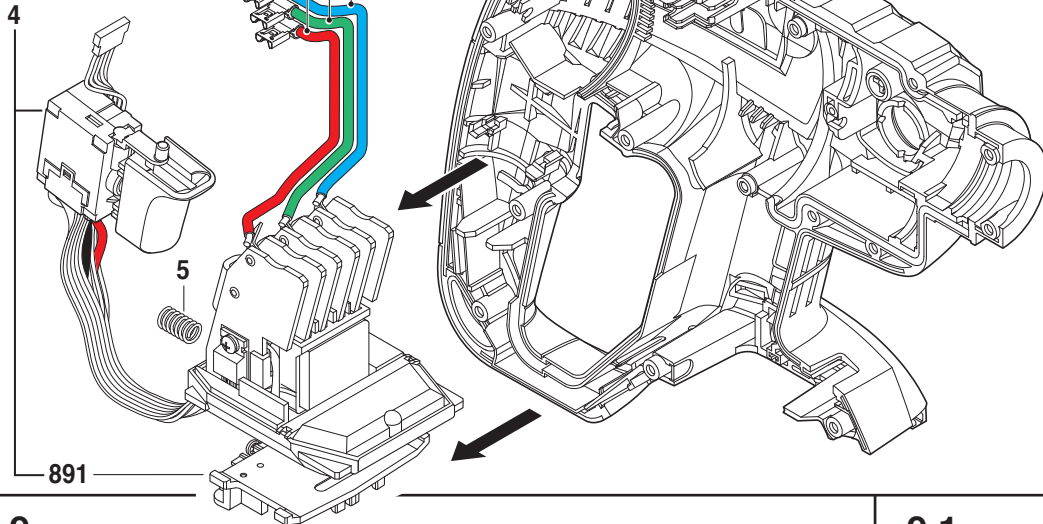

8.

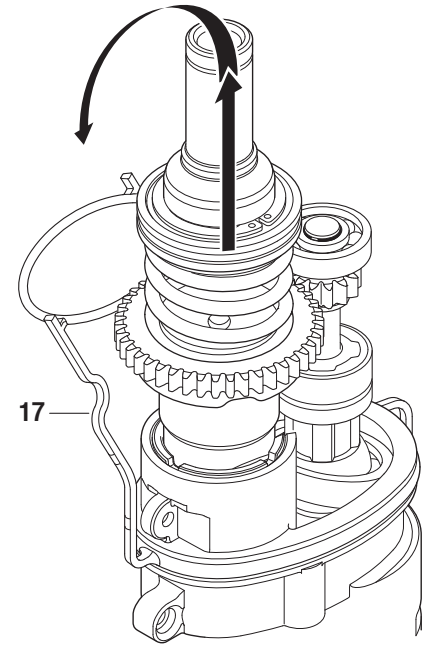
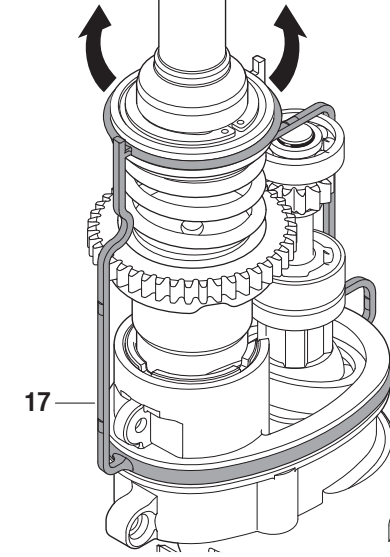

9.

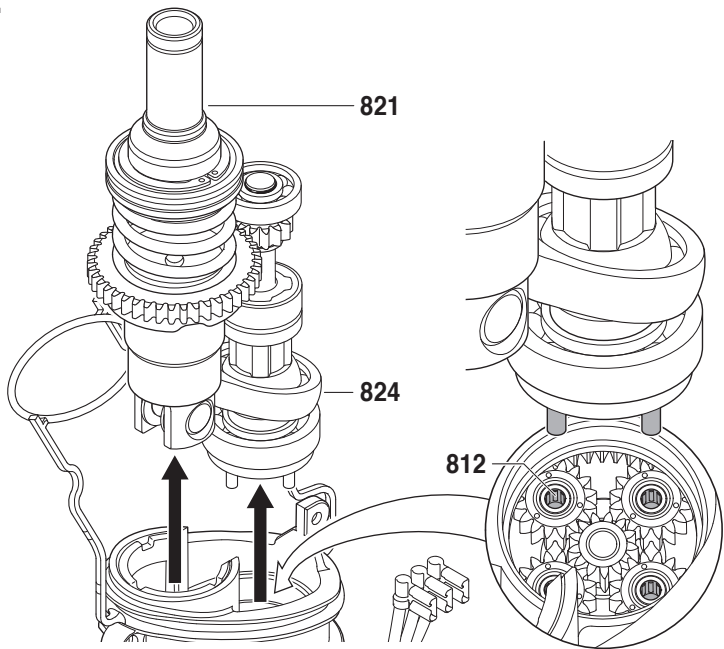

9.1

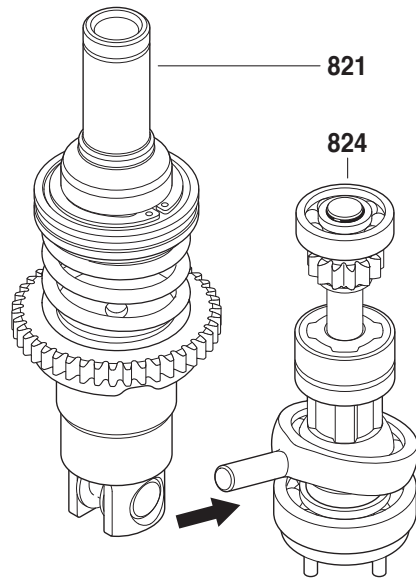

## 9.2

- a** Hilfswerkzeug zum Selbstanfertigen  
Auxiliary tool (for your own manufacture)  
Outil auxiliaire (fabrication locale)  
Utile (fabricación particular)

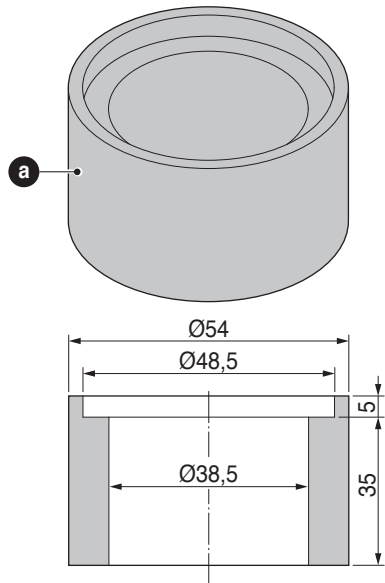

Maße in mm  
Dimensions in mm  
Cotes en mm  
Medidas en mm

## 9.3

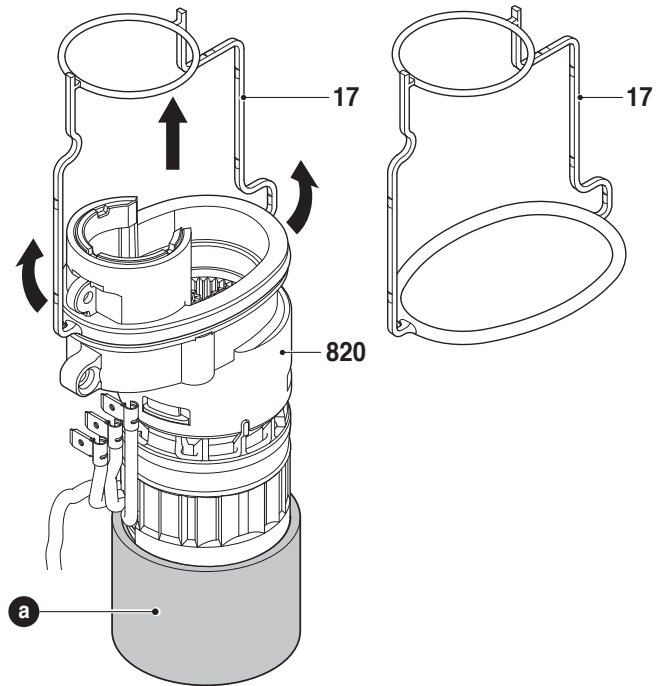

## 10.

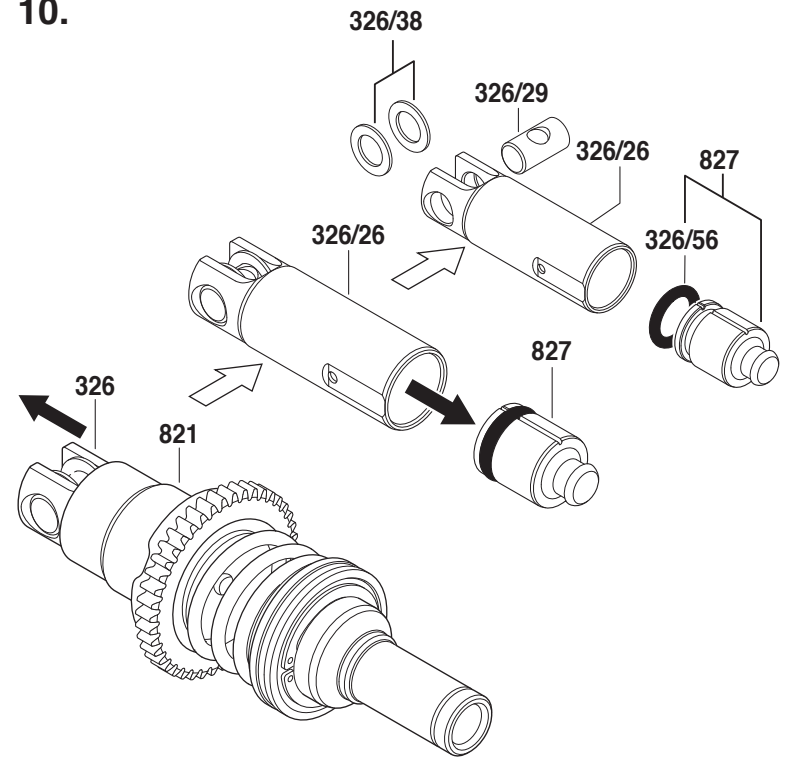

**11.**

**c** Hilfswerkzeug zum Selbstanfertigen  
 Auxiliary tool (for your own manufacture)  
 Outil auxiliaire (fabrication locale)  
 Utile (fabricación particular)

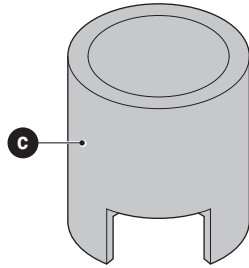
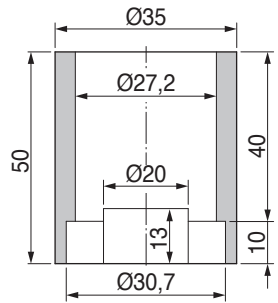

Maße in mm  
 Dimensions in mm  
 Cotes en mm  
 Medidas en mm

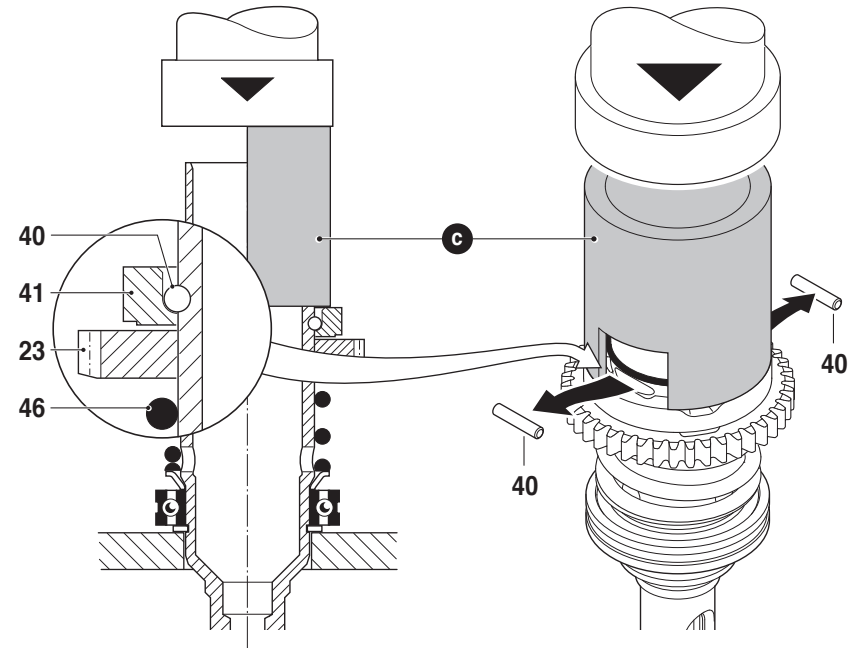
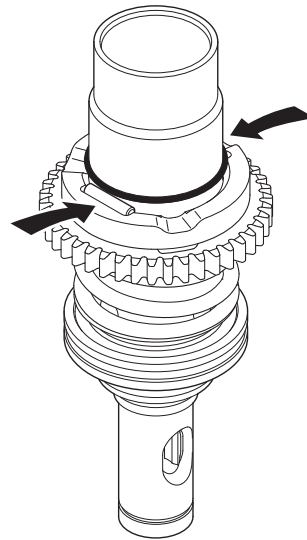
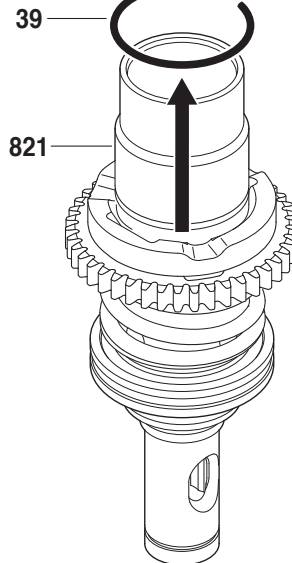
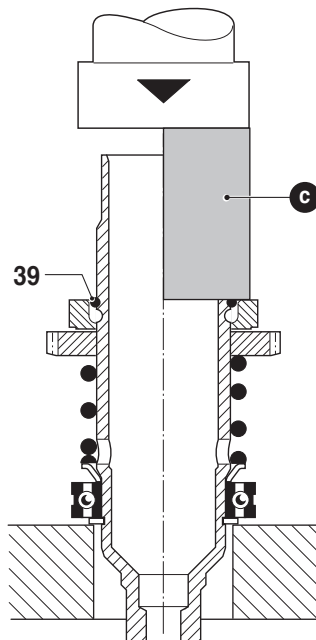
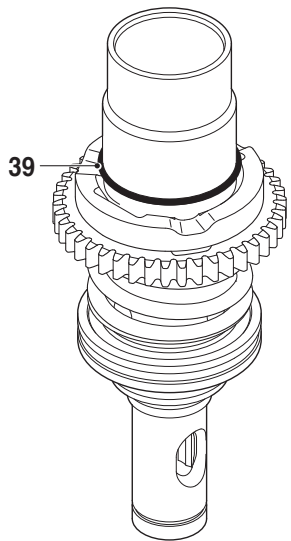
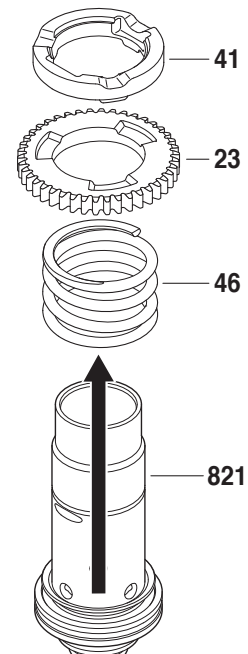
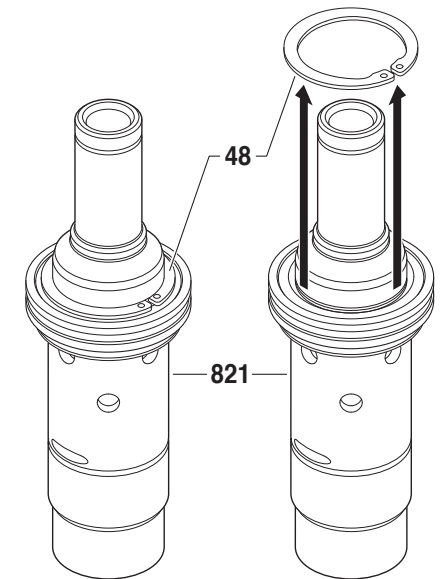
**11.1****11.2****11.3****11.4**

11.5

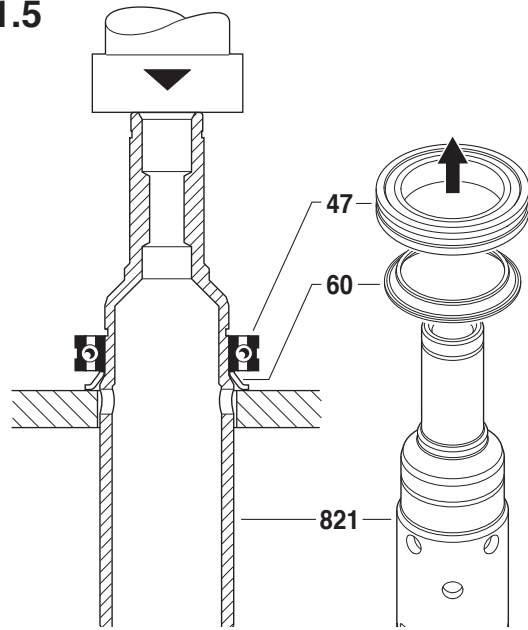

11.6

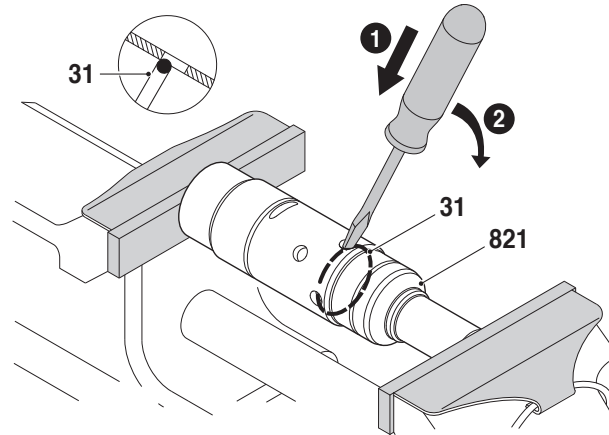

Hilfswerkzeug zum Selbstanfertigen  
 Auxiliary tool (for your own manufacture)  
 Outil auxiliaire (fabrication locale)  
 Utile (fabricación particular)

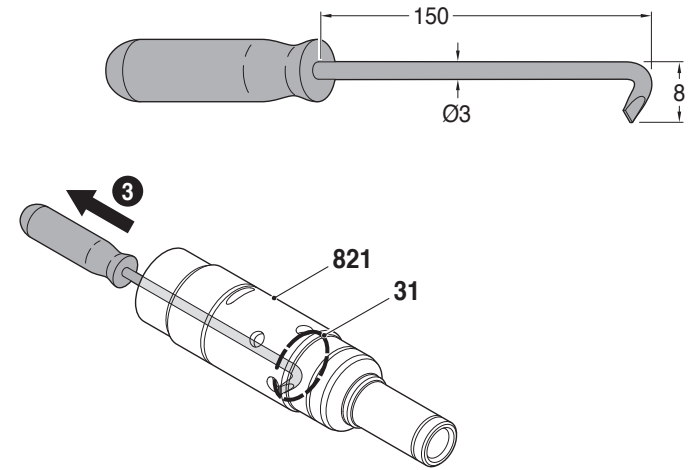

11.7

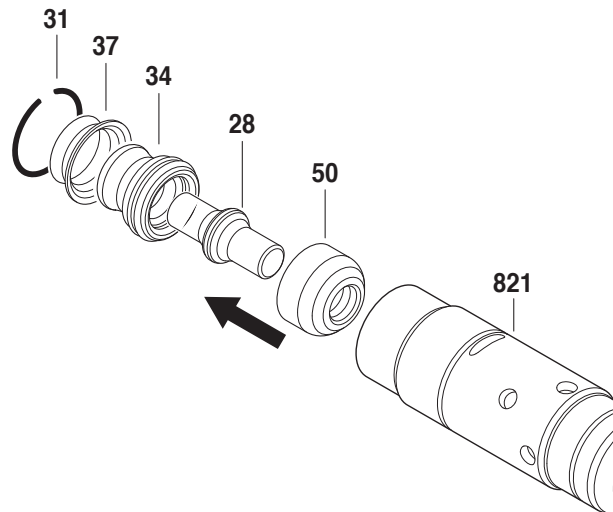

12.

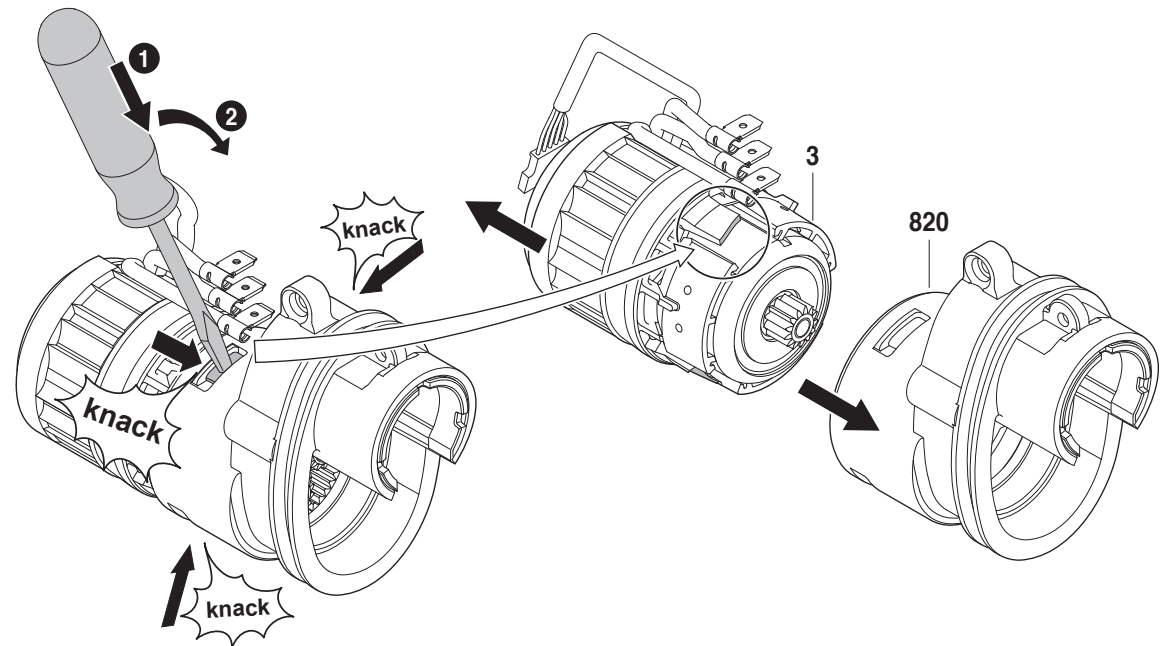

13.

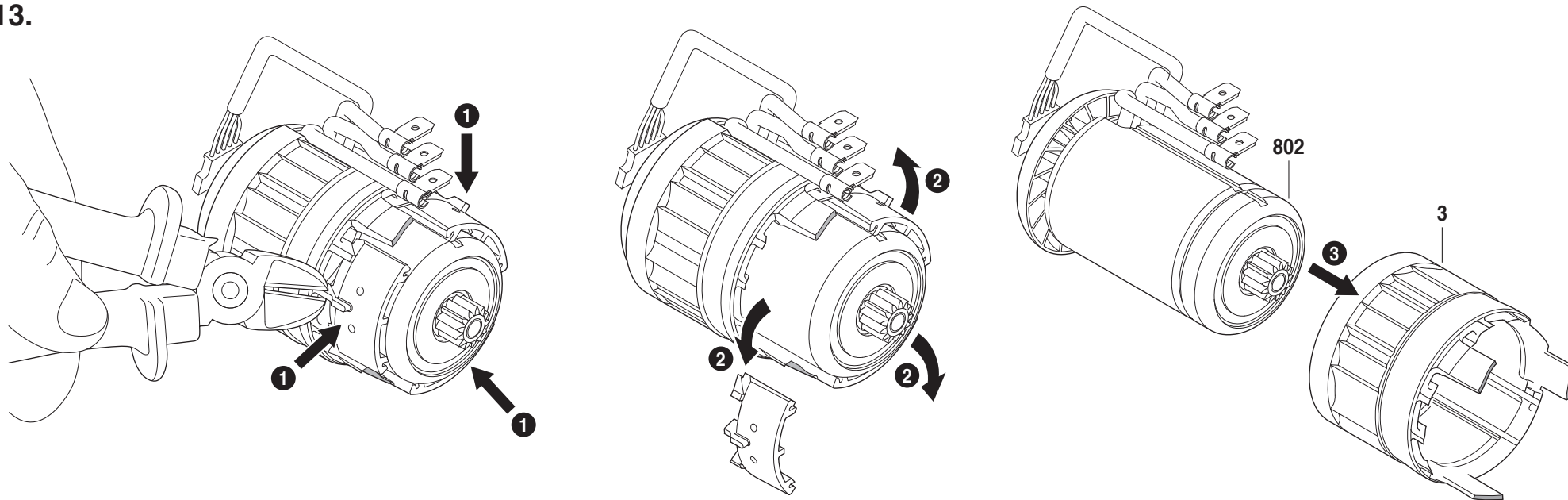

14.

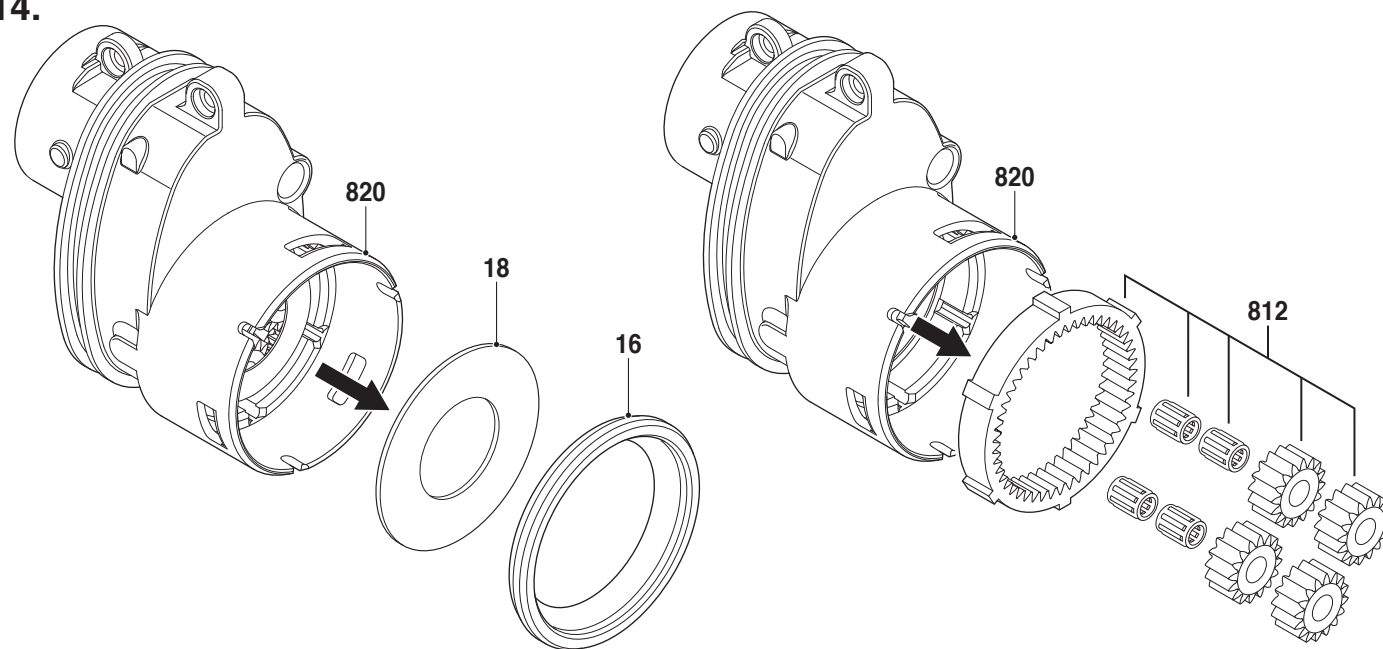

14.1

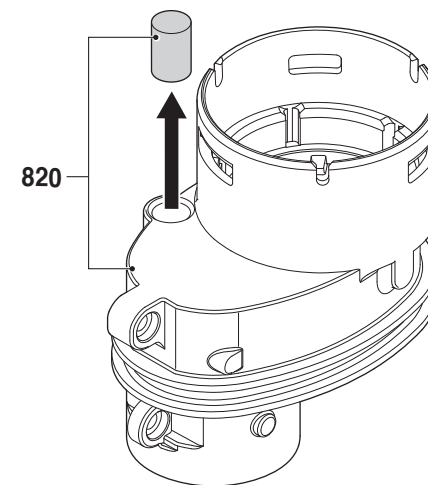



15.

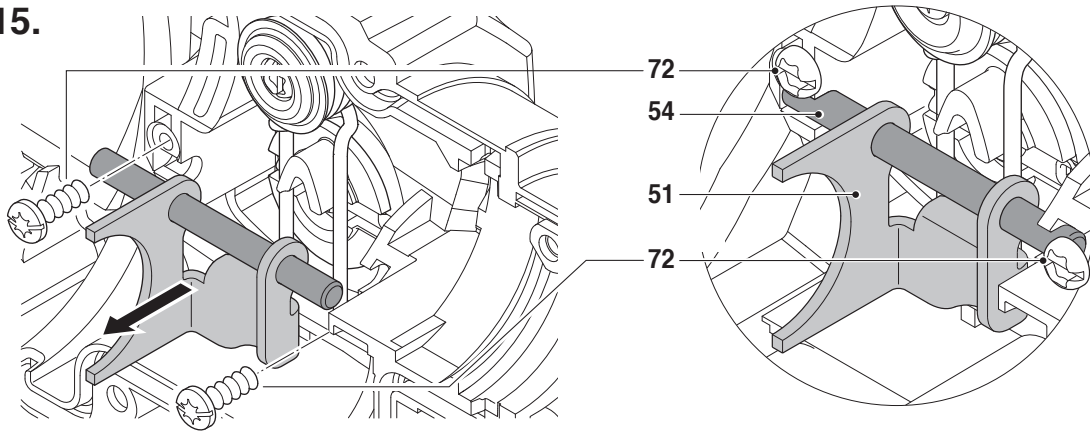

16.

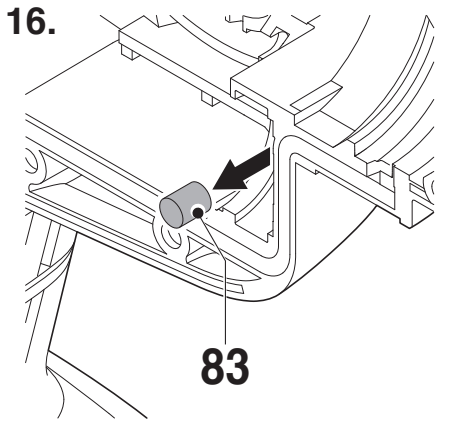

17.

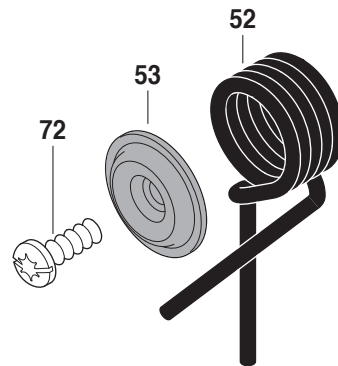
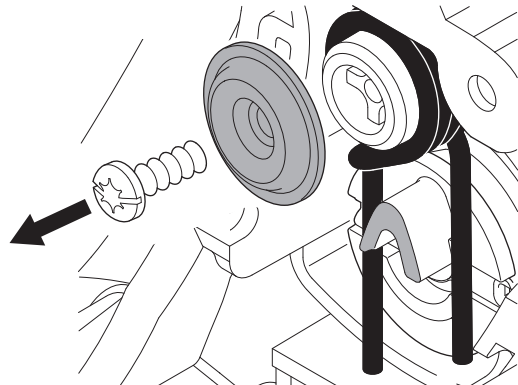

18.

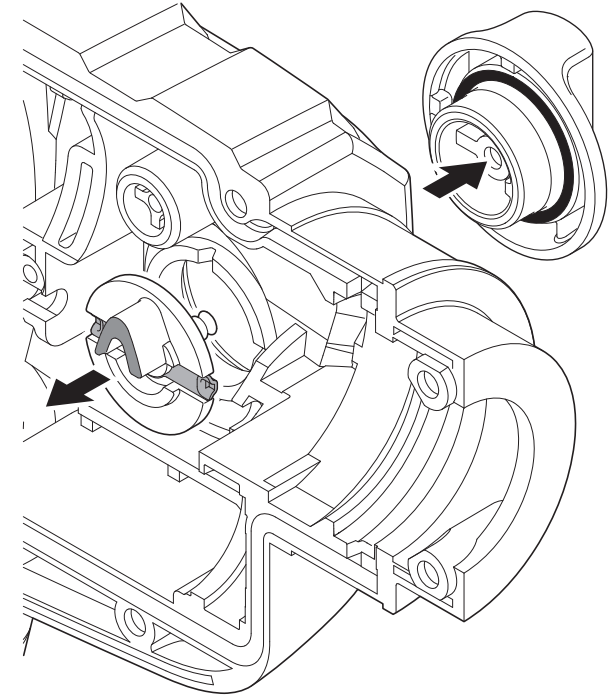

18.1

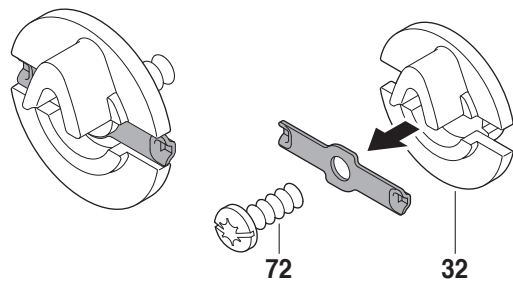

18.2

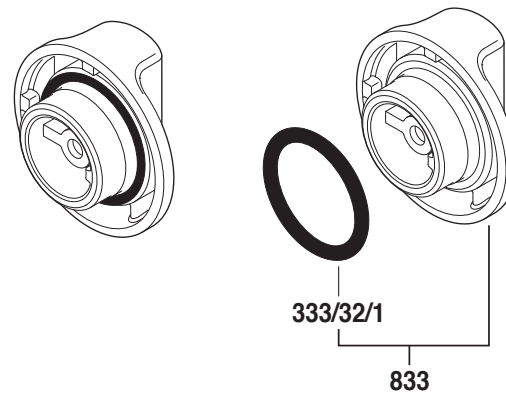

### Zusammenbau

Montage nach Explosionszeichnung und diesem Instandsetzungshinweis.

Alle Teile sind gereinigt, abgenutzte und beschädigte Teile werden ersetzt.

Nur Original-Ersatzteile verwenden.

Zähne aller Zahnräder mit Fett **1 615 430 001** bestreichen.

Bitte Schmierhinweise beachten!

### Assembly

Assembly using explosion drawings and these repair instructions!

Clean all parts, replace worn-out and damaged parts.

Use only original spare parts!

Grease all gear teeth **1 615 430 001**.

Please note lubrication instructions!

### Montage

Le montage s'effectue selon la vue éclatée et les instructions de réparation suivantes.

Toutes les pièces sont nettoyées, les pièces usées ou endommagées doivent être remplacées par des nouvelles. Pour le remplacement de pièces, n'utiliser que des pièces d'origine.

Les dents graisser **1 615 430 001**.

Respecter les instructions de graissage!

### Montaje

Realizar el montaje conforme a los dibujos en perspectiva y a estas instrucciones de reparación.

Todas las piezas deben estar limpias. Las piezas desgastadas o dañadas deben reemplazarse por piezas nuevas. Utilizar solamente piezas de repuesto originales.

Dientes engrasar **1 615 430 001**.

Observar las instrucciones de lubricación!

21.

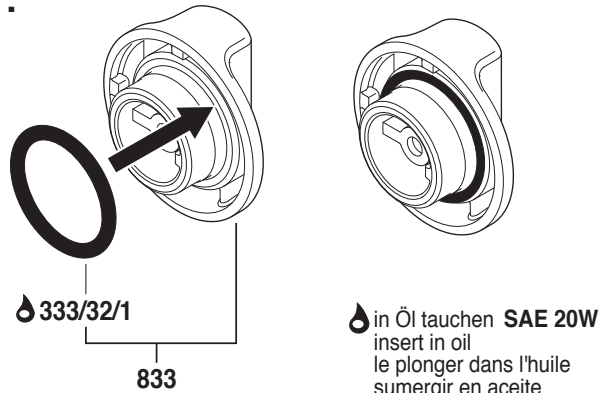

21.1

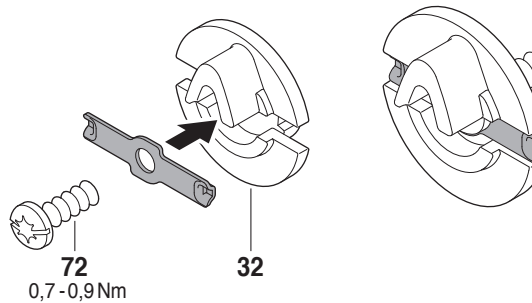

21.2

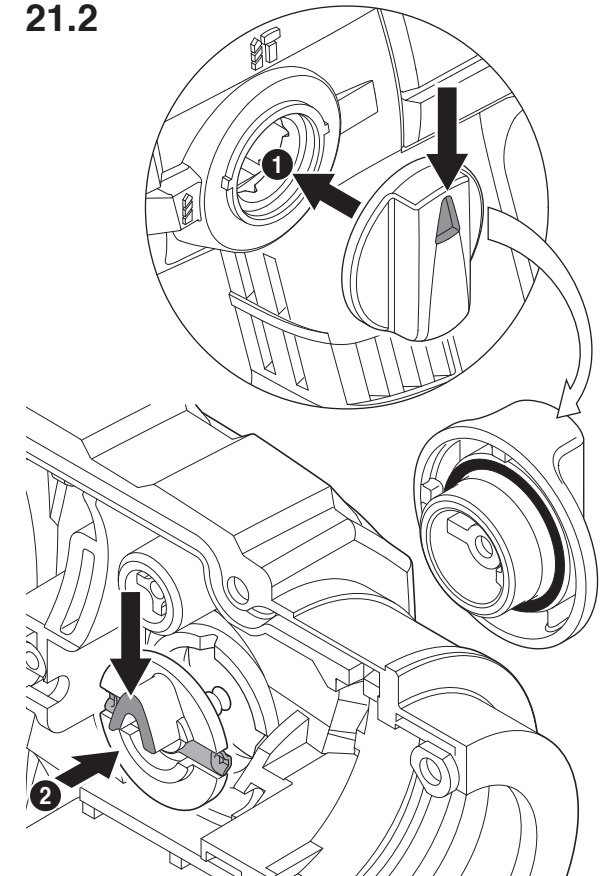

22.

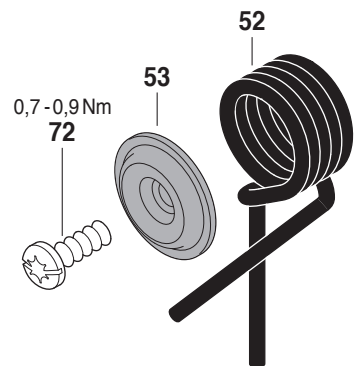

22.1

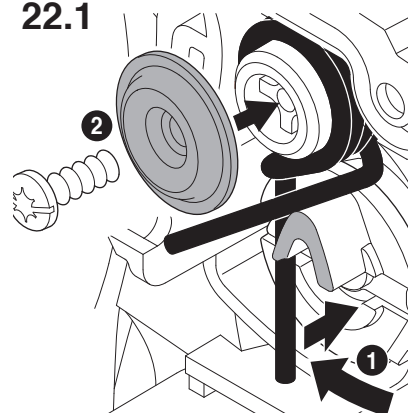

22.2

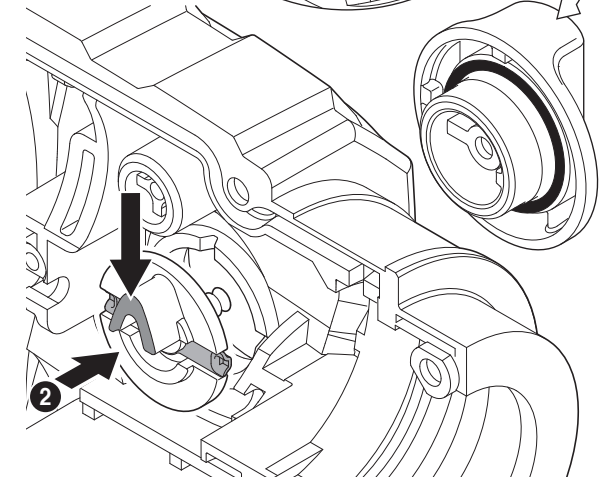
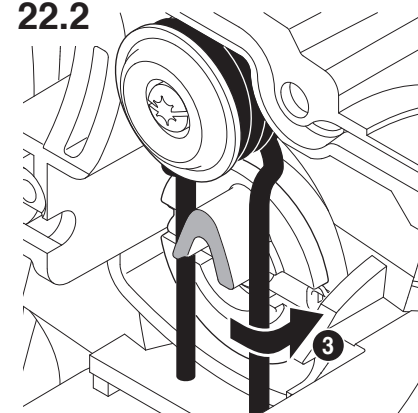

### Zusammenbau

Montage nach Explosionszeichnung und diesem Instandsetzungshinweis.

Alle Teile sind gereinigt, abgenutzte und beschädigte Teile werden ersetzt.

Nur Original-Ersatzteile verwenden.

Zähne aller Zahnräder mit Fett **1 615 430 001** bestreichen.

Bitte Schmierhinweise beachten!

### Assembly

Assembly using explosion drawings and these repair instructions!

Clean all parts, replace worn-out and damaged parts.

Use only original spare parts!

Grease all gear teeth **1 615 430 001**.

Please note lubrication instructions!

### Montage

Le montage s'effectue selon la vue éclatée et les instructions de réparation suivantes.

Toutes les pièces sont nettoyées, les pièces usées ou endommagées doivent être remplacées par des nouvelles. Pour le remplacement de pièces, n'utiliser que des pièces d'origine.

Les dents graisser **1 615 430 001**.

Respecter les instructions de graissage!

### Montaje

Realizar el montaje conforme a los dibujos en perspectiva y a estas instrucciones de reparación.

Todas las piezas deben estar limpias. Las piezas desgastadas o dañadas deben reemplazarse por piezas nuevas. Utilizar solamente piezas de repuesto originales.

Dientes engrasar **1 615 430 001**.

Observar las instrucciones de lubricación!

21.

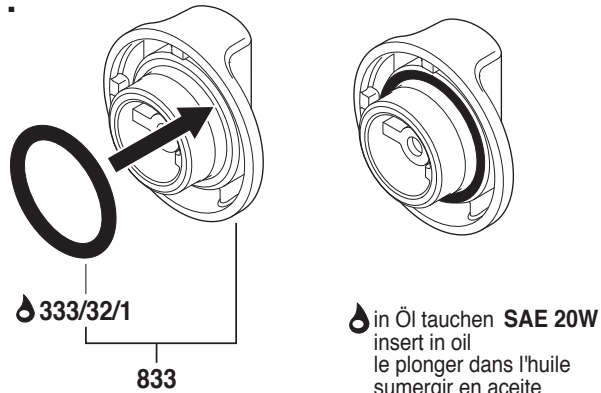

21.1

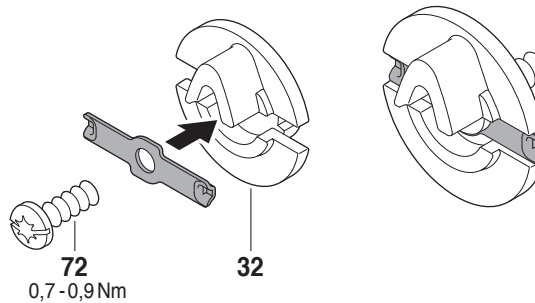

21.2

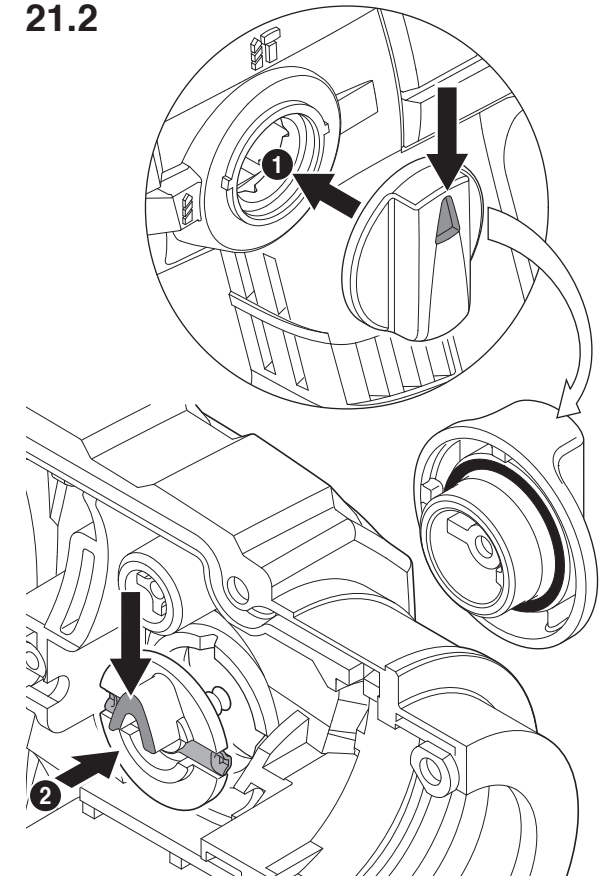

22.

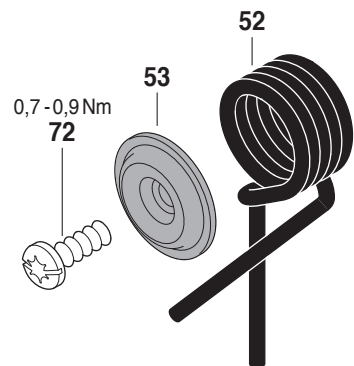

22.1

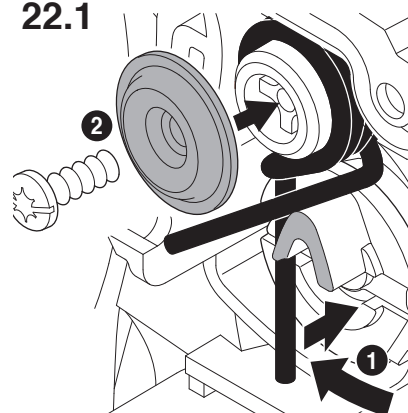

22.2

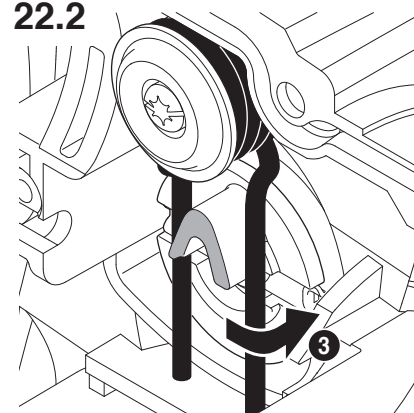

26.

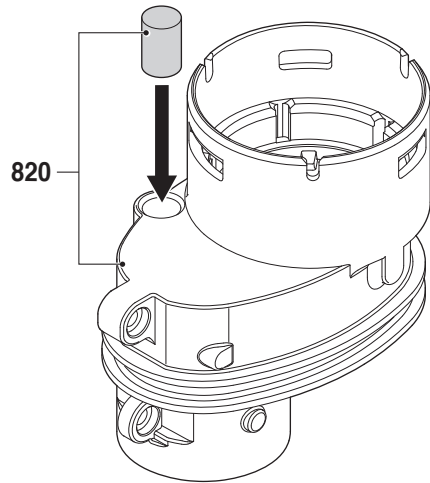

27.

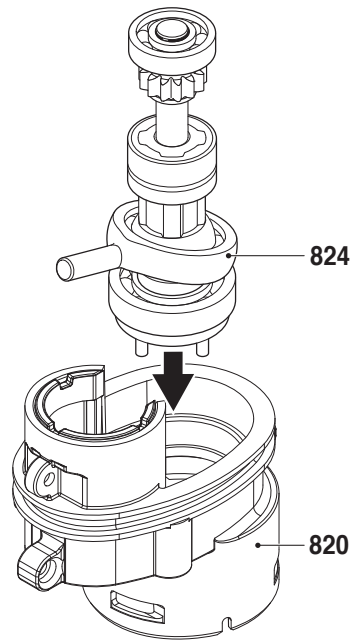

27.1

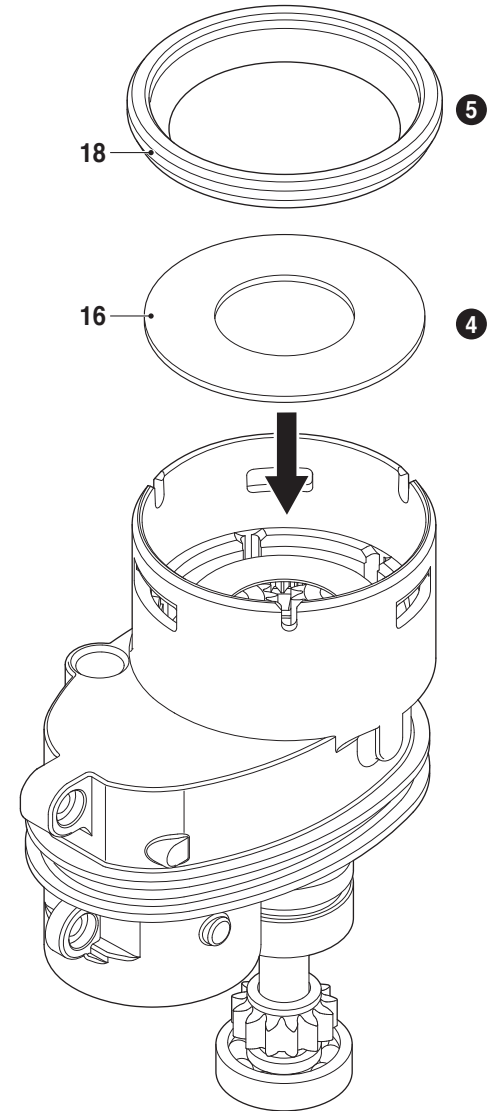
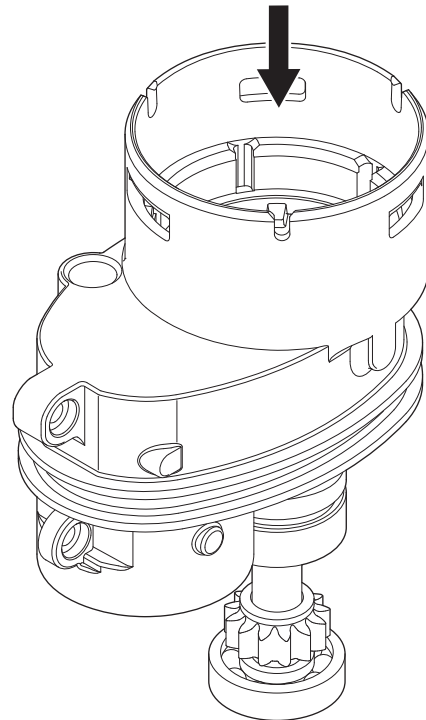
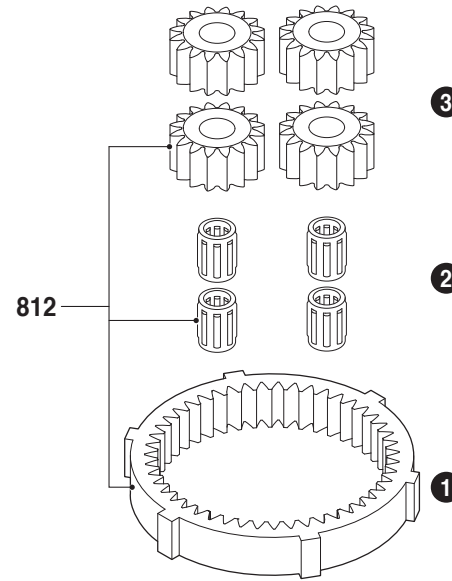



27.2

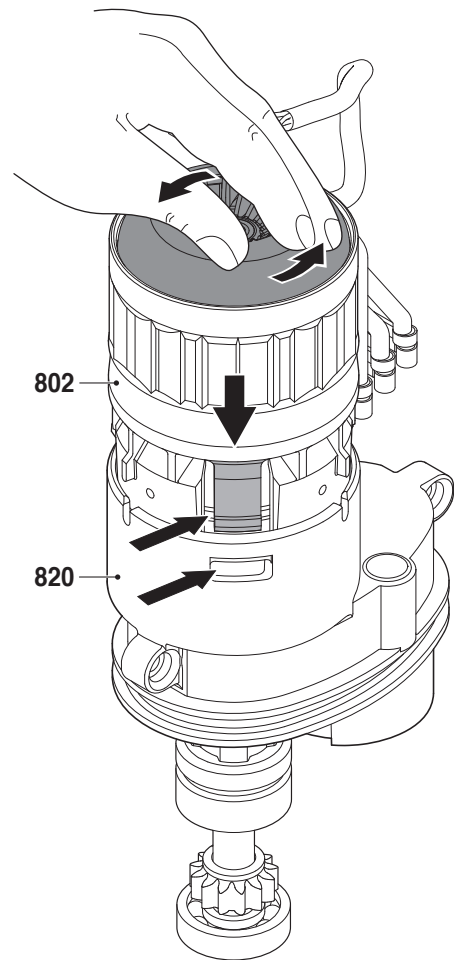

27.3

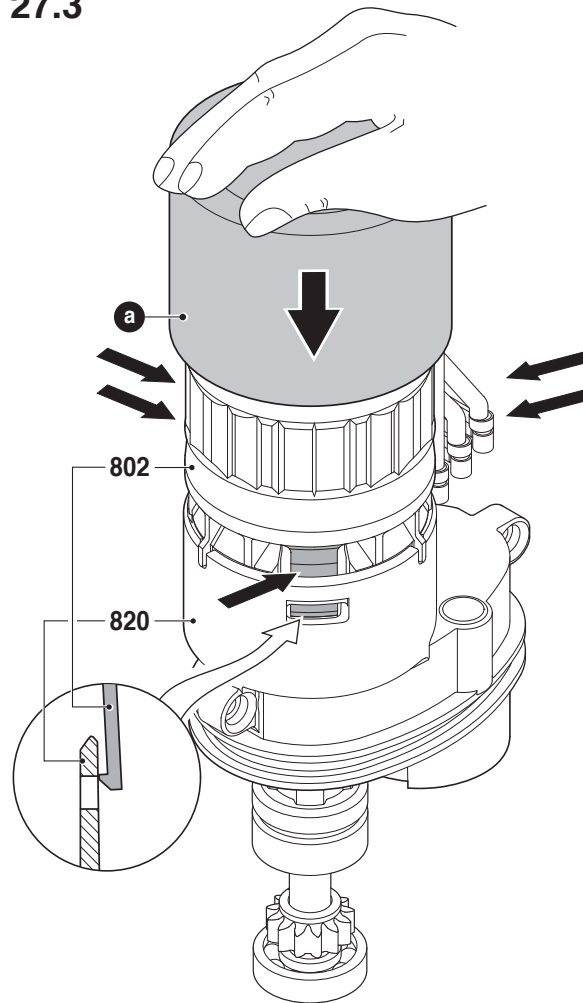

27.4

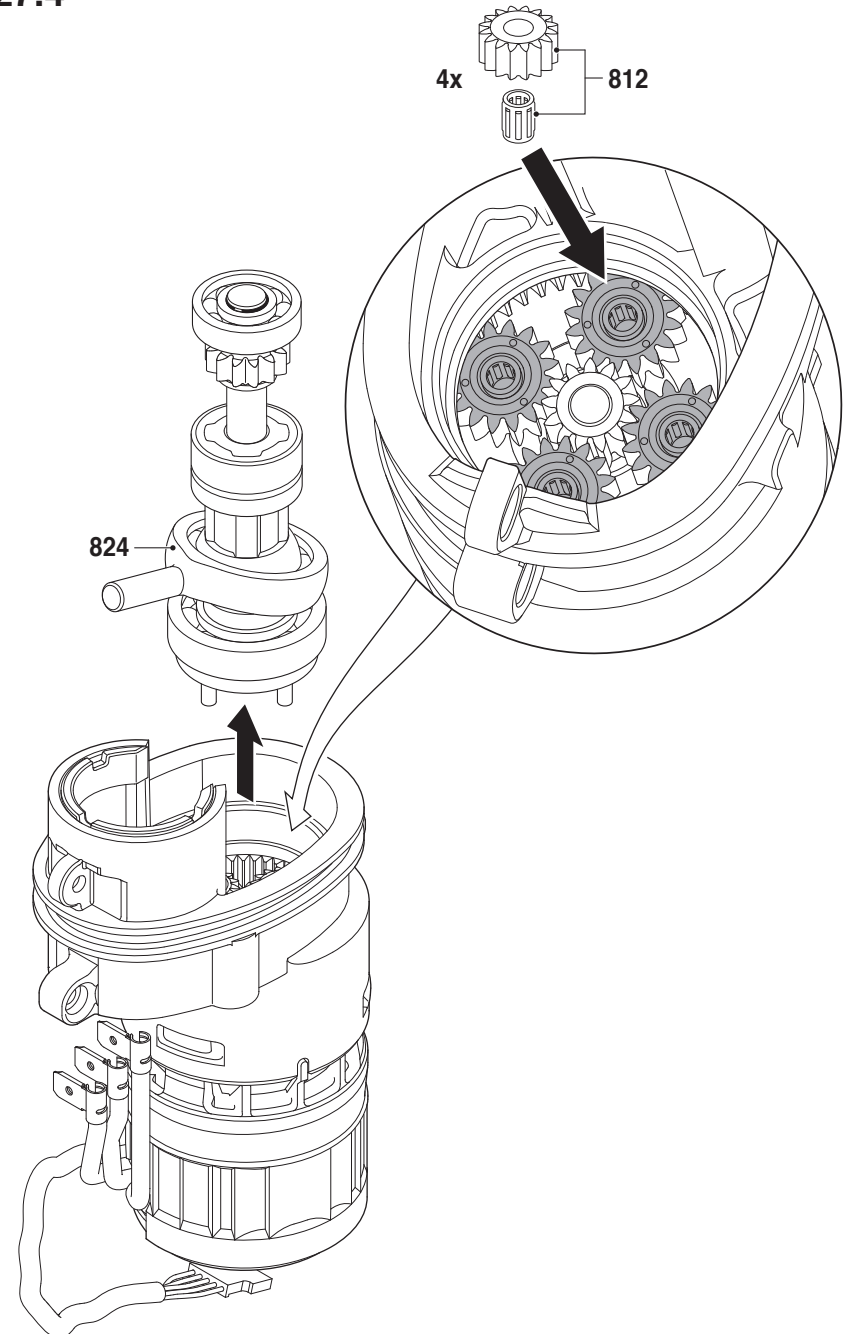

## 27.5

- b** Hilfswerkzeug zum Selbstanfertigen  
 Auxiliary tool (for your own manufacture)  
 Outil auxiliaire (fabrication locale)  
 Utile (fabricación particular)

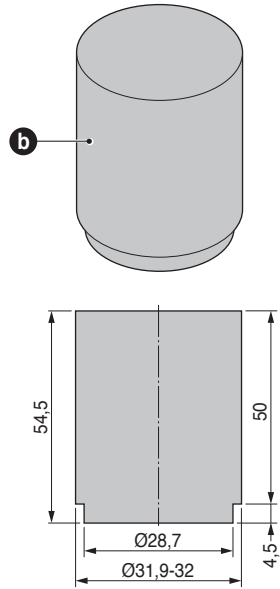

Maße in mm  
 Dimensions in mm  
 Cotes en mm  
 Medidas en mm

## 27.6

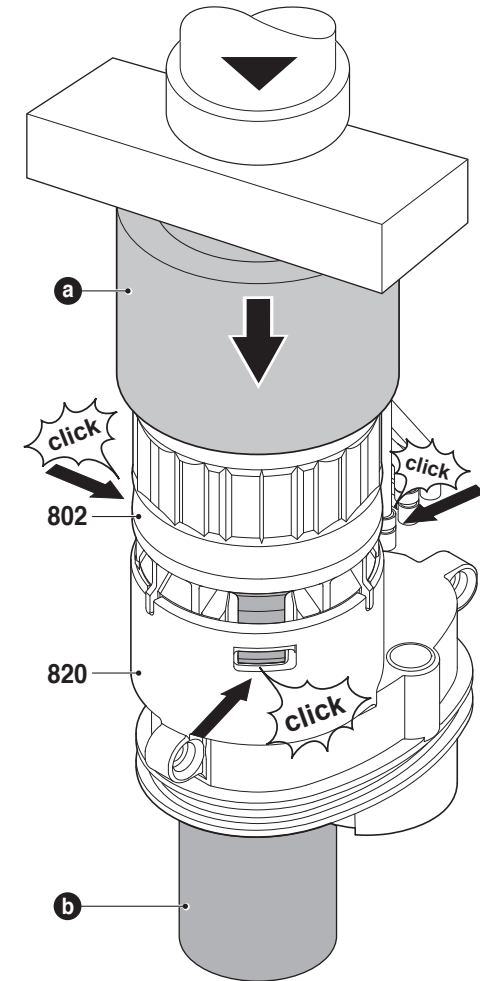
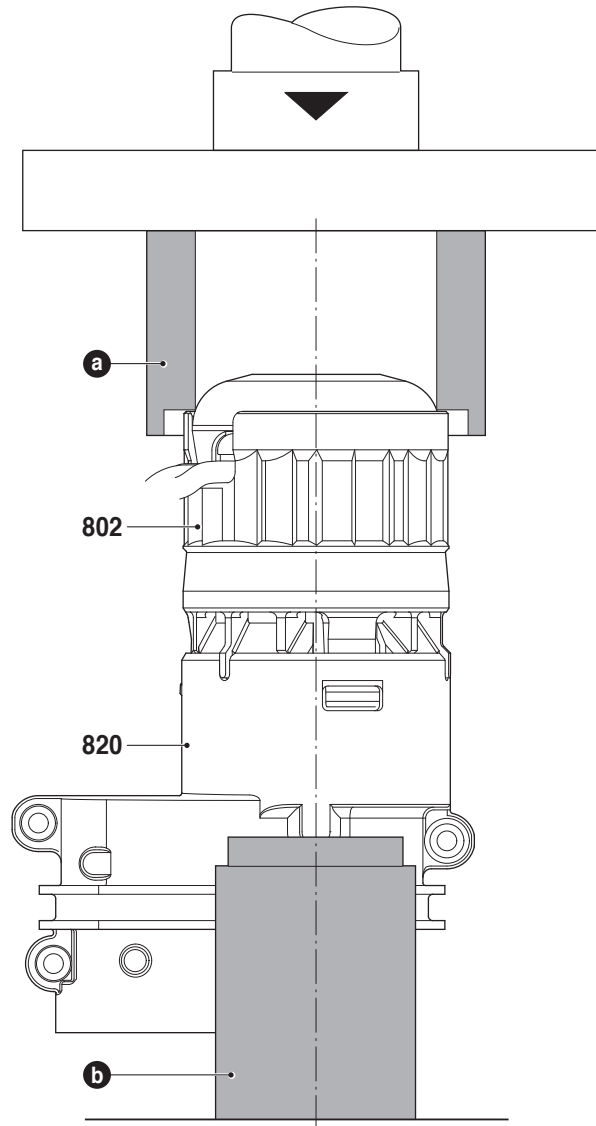

28.

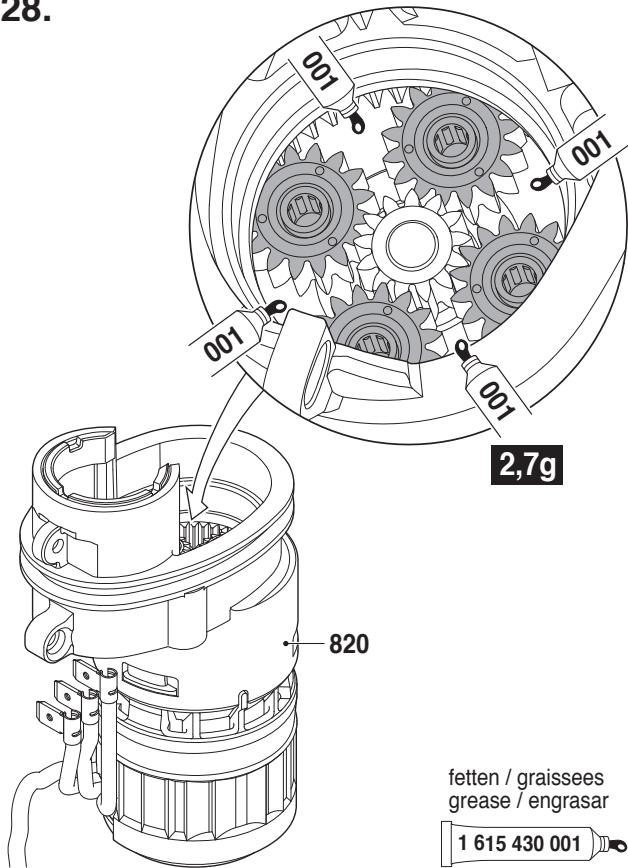

29.

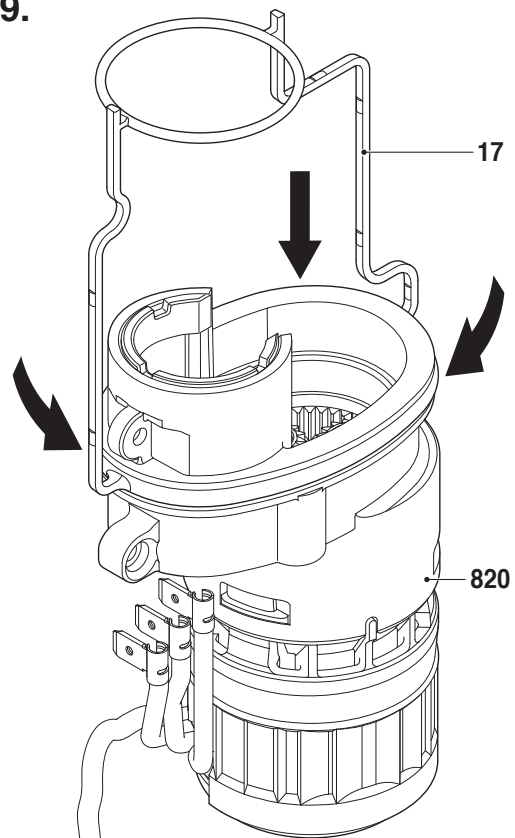

30.

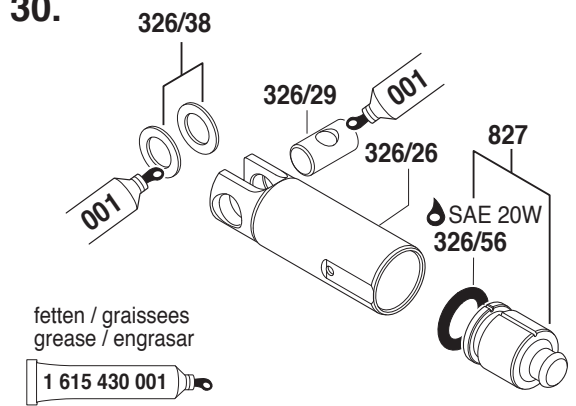

30.1

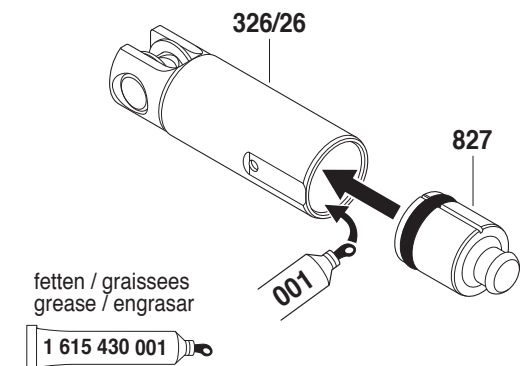

31.

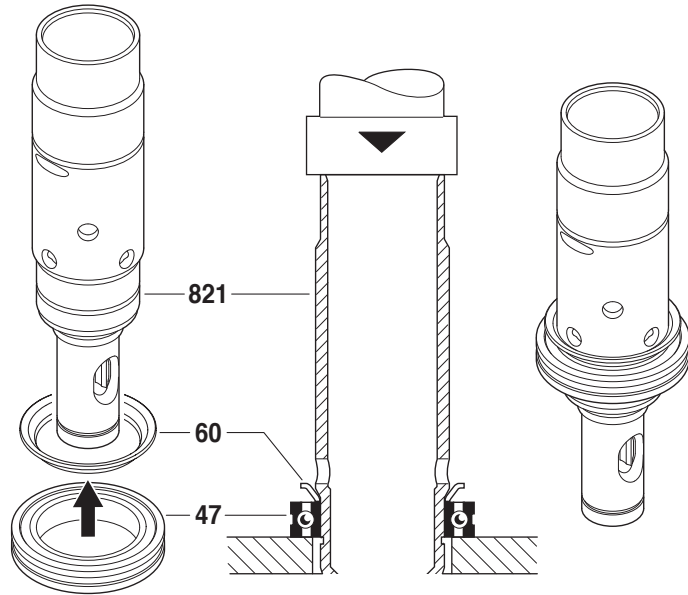

31.1

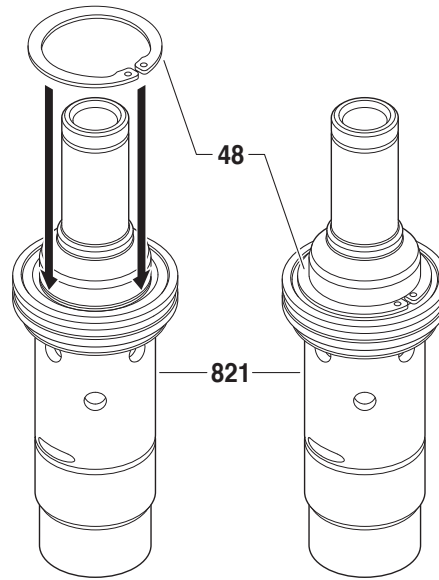

31.2

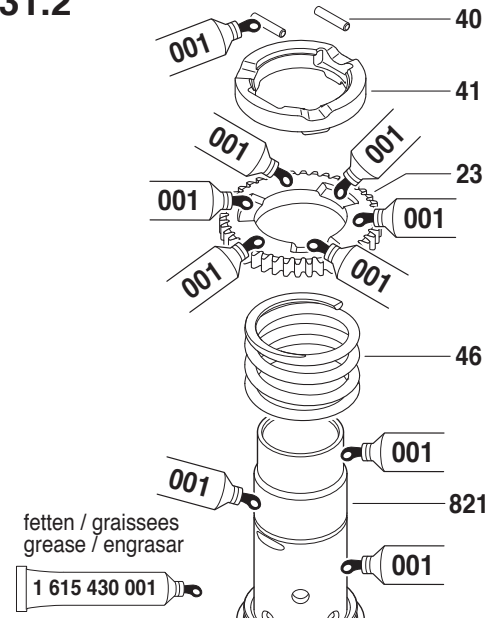

31.3

**C** Hilfswerkzeug zum Selbstanfertigen  
Auxiliary tool (for your own manufacture)  
Outil auxiliaire (fabrication locale)  
Utile (fabricación particular)

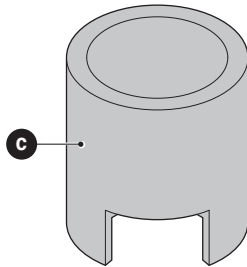
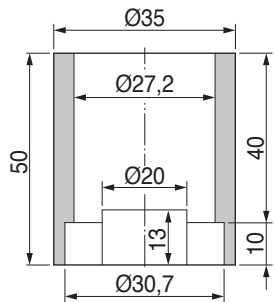

Maße in mm  
Dimensions in mm  
Cotes en mm  
Medidas en mm

31.4

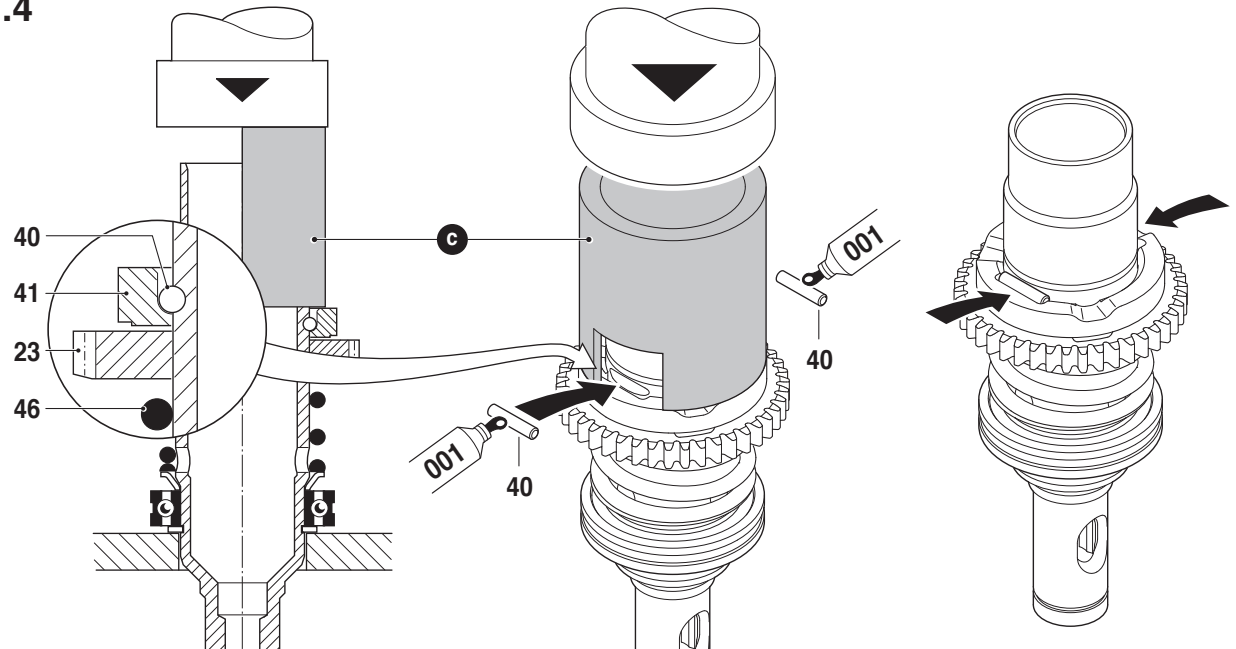



### 31.5

**d** Hilfswerkzeug zum Selbstanfertigen  
 Auxiliary tool (for your own manufacture)  
 Outil auxiliaire (fabrication locale)  
 Utile (fabricación particular)

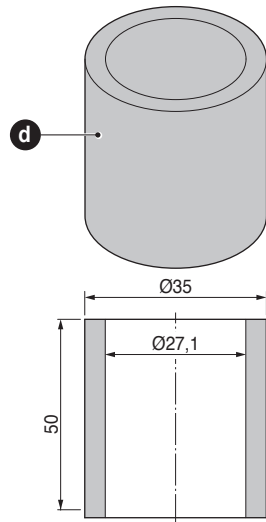

Maße in mm  
 Dimensions in mm  
 Cotes en mm  
 Medidas en mm

### 31.6

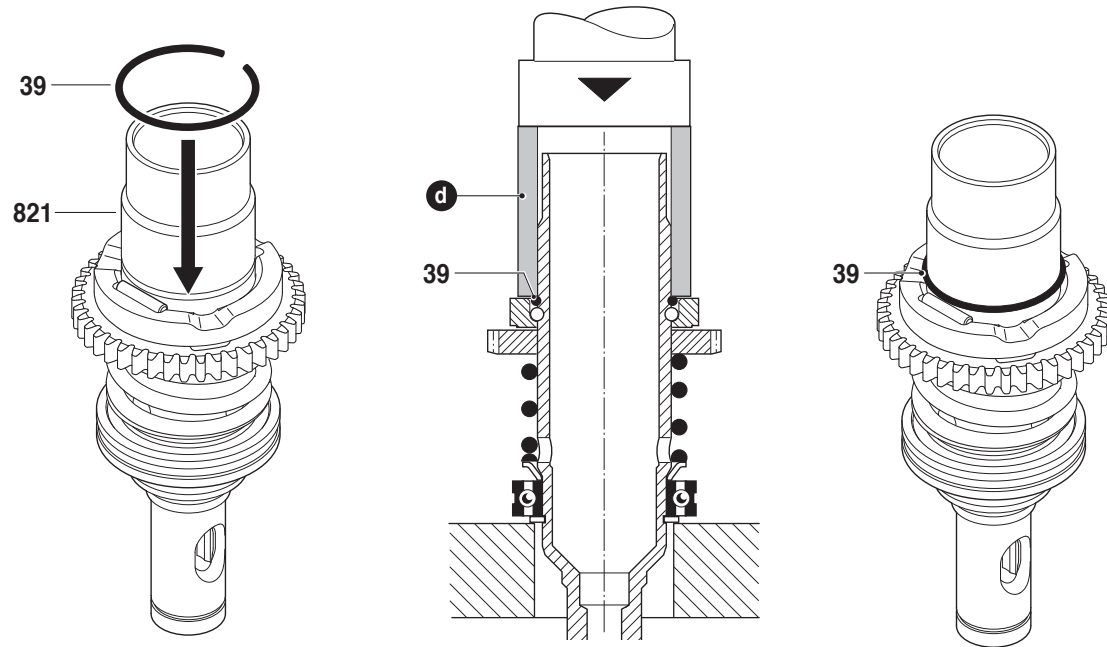

### 31.7

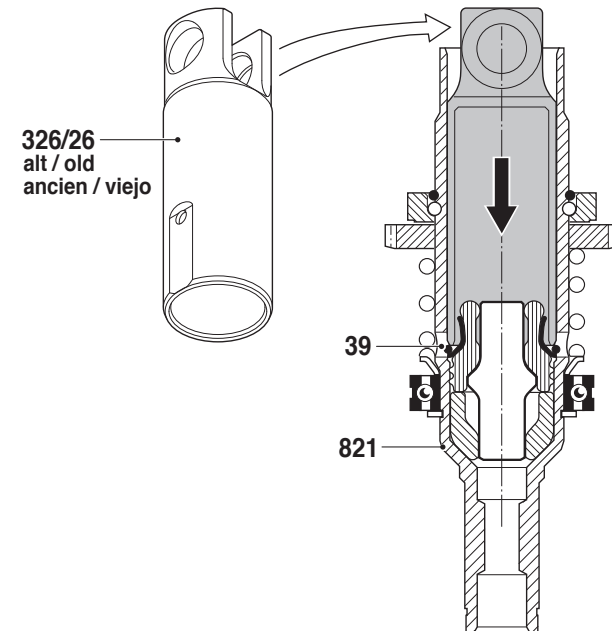
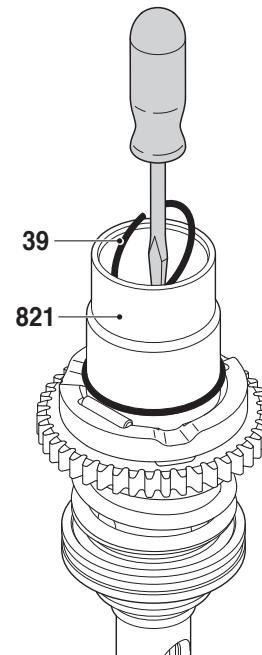
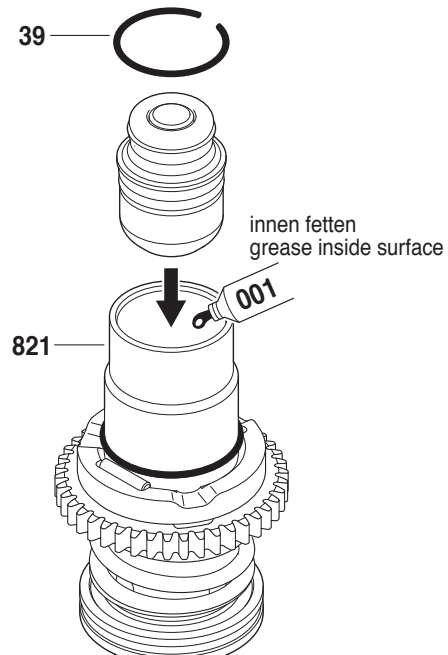
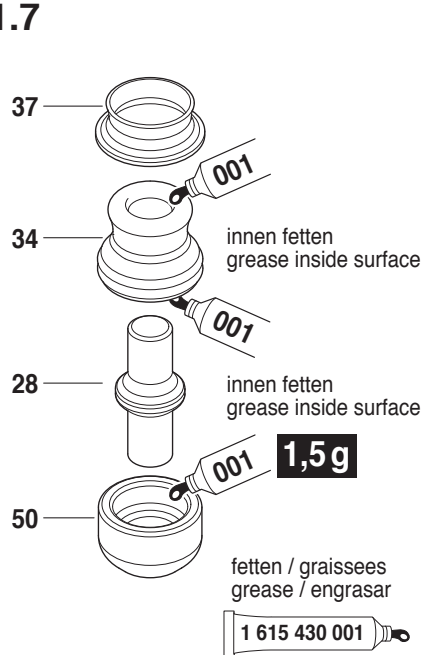

32.

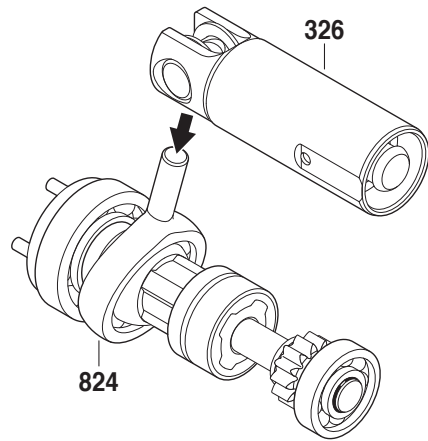

32.1

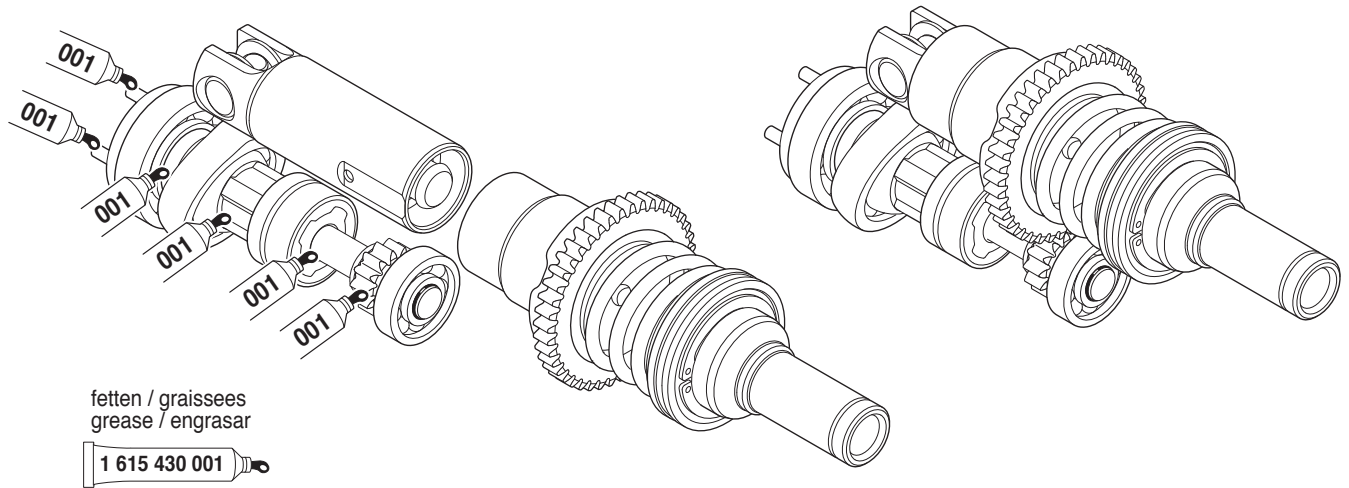

32.2

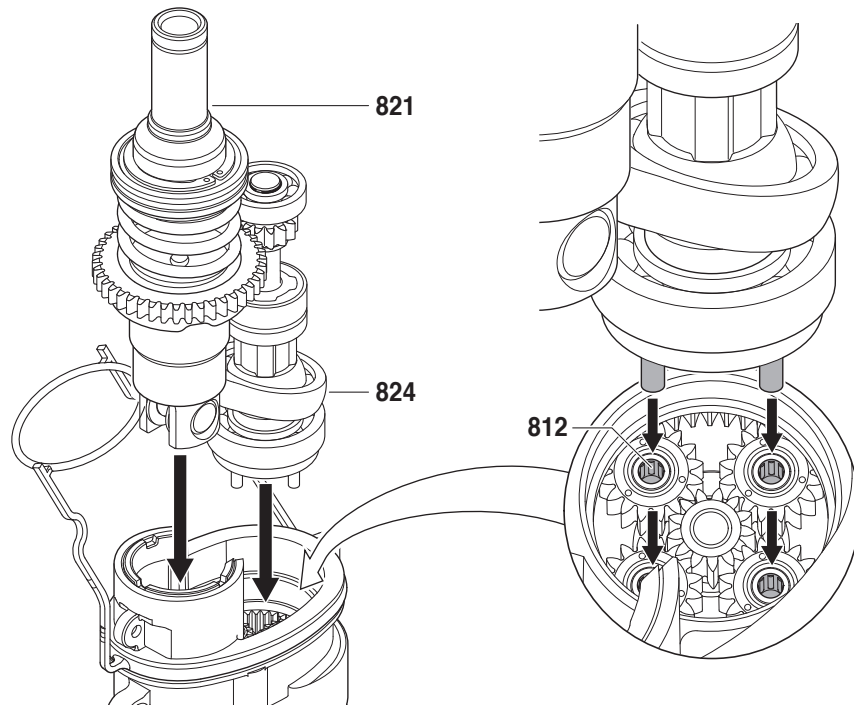

33.

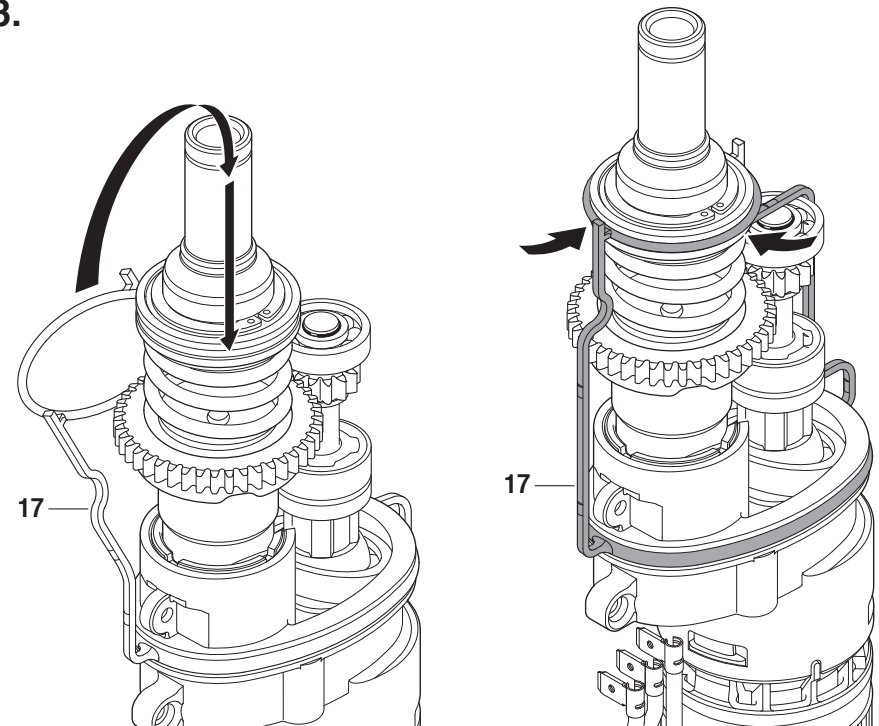

34.

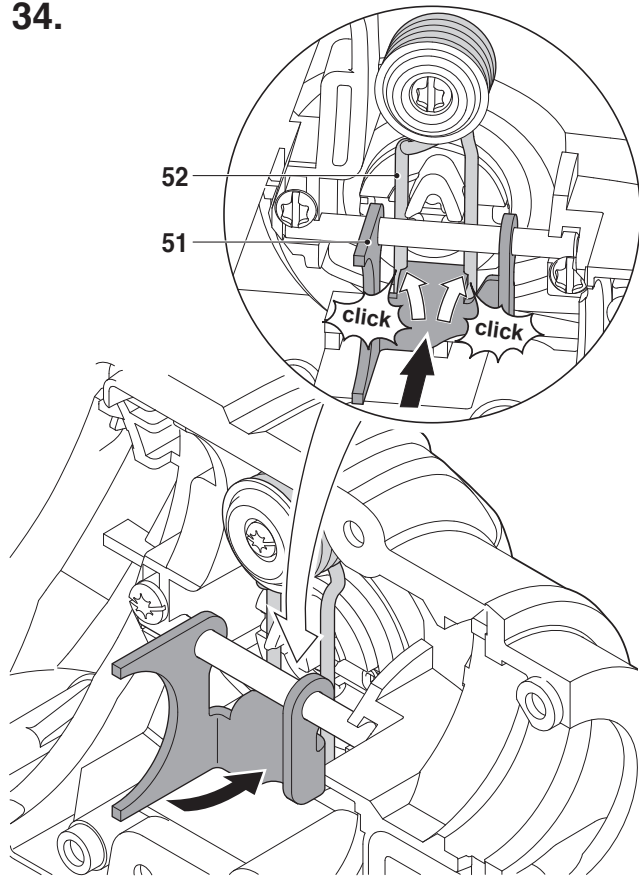

35.

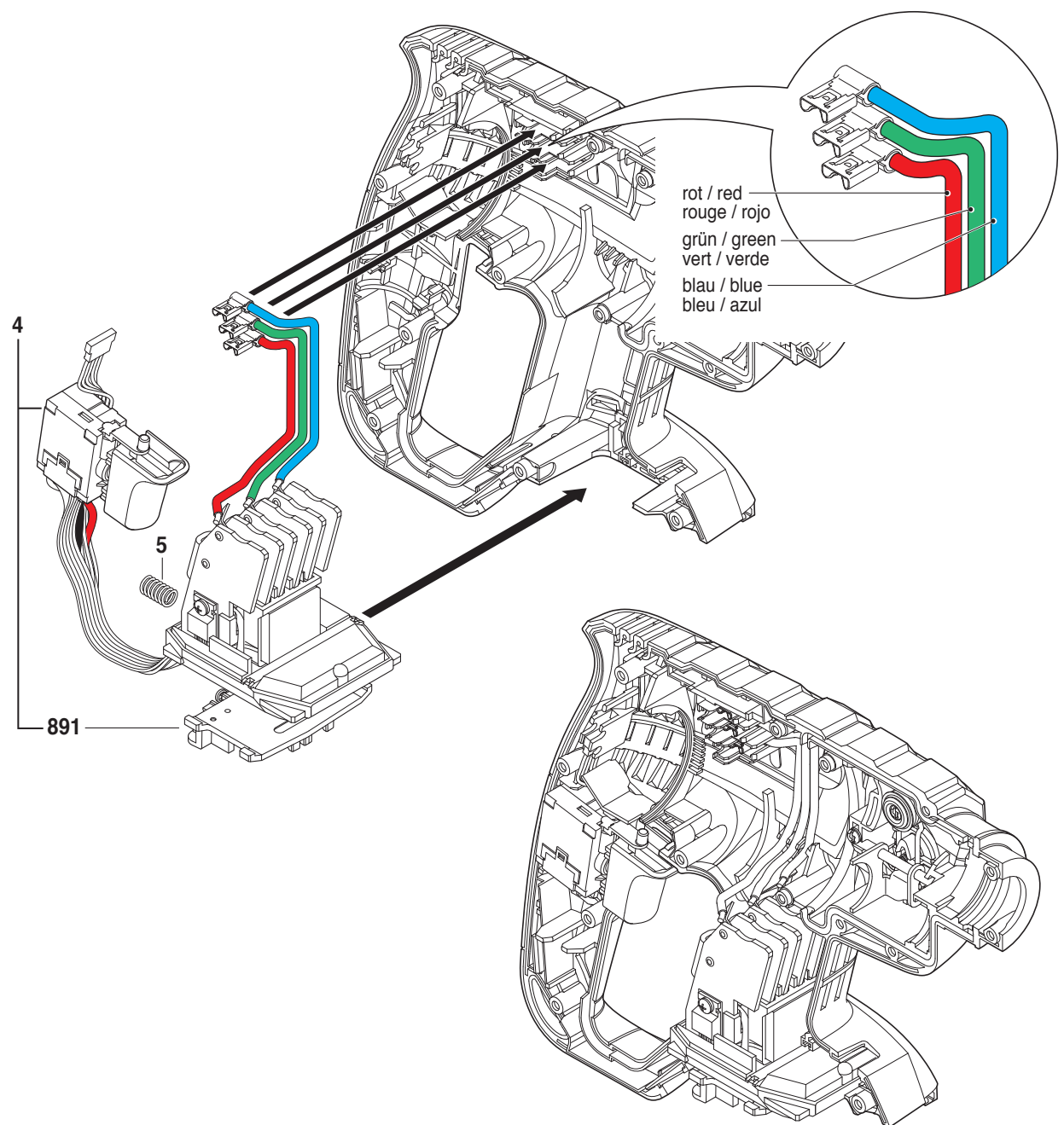

36.

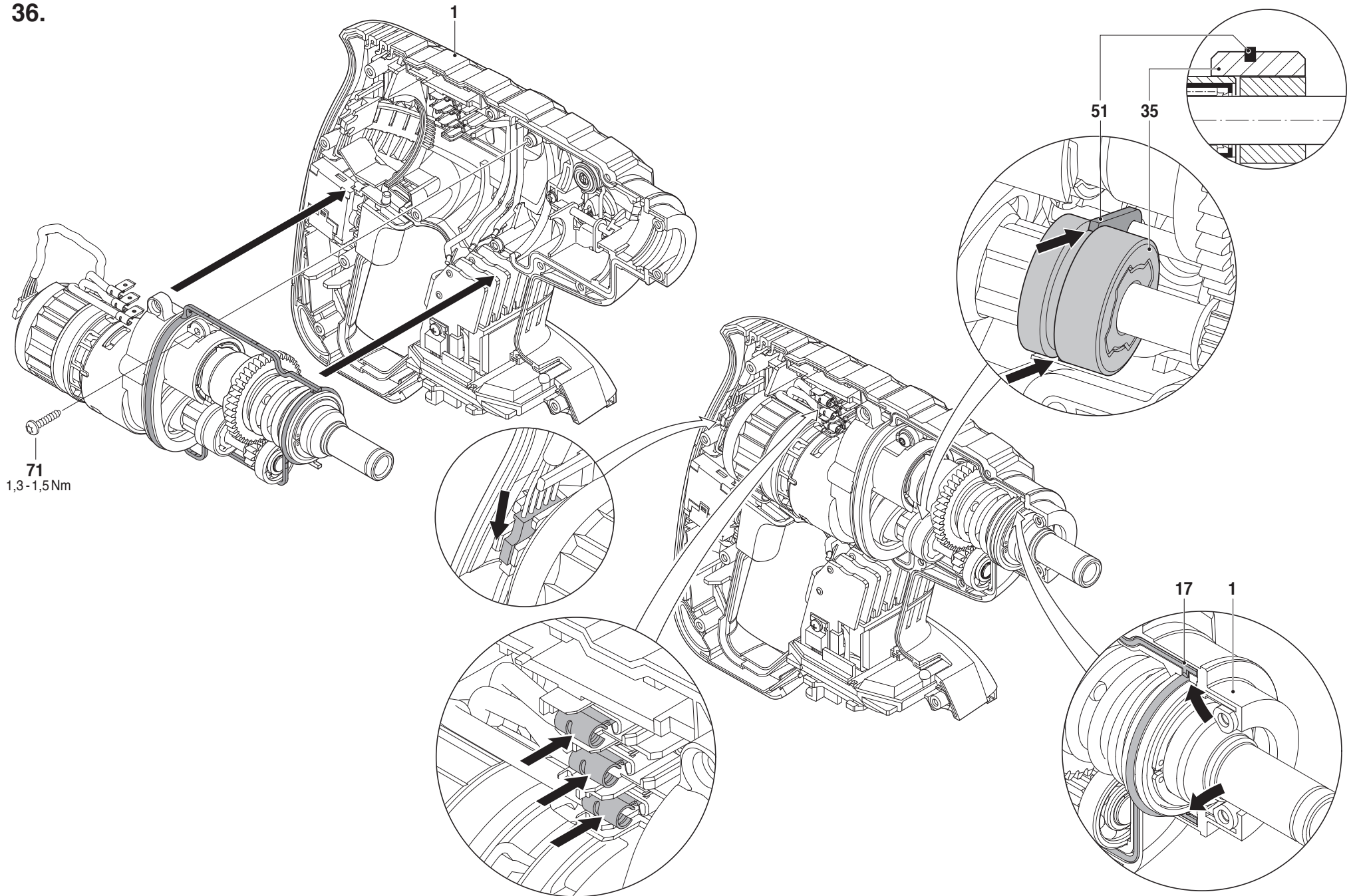



37.

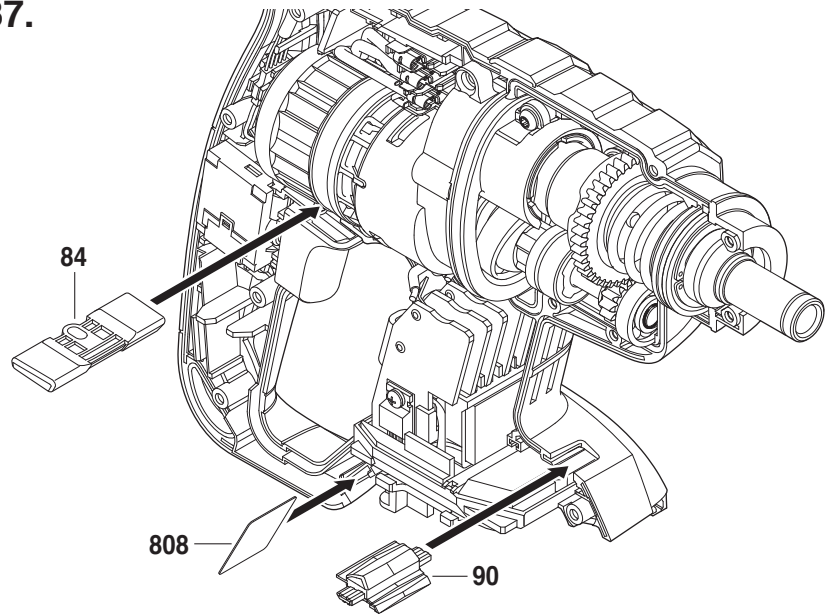

38.

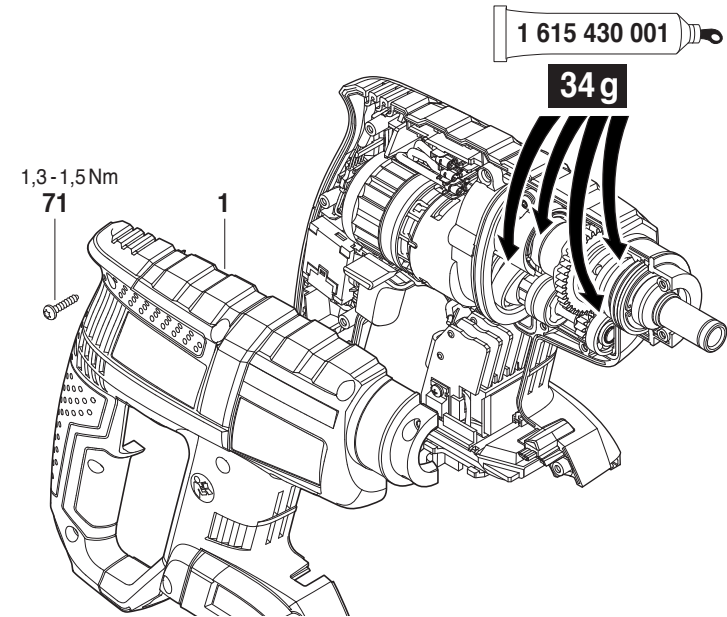

39.

Beachten  
Caution  
Attention  
Observar

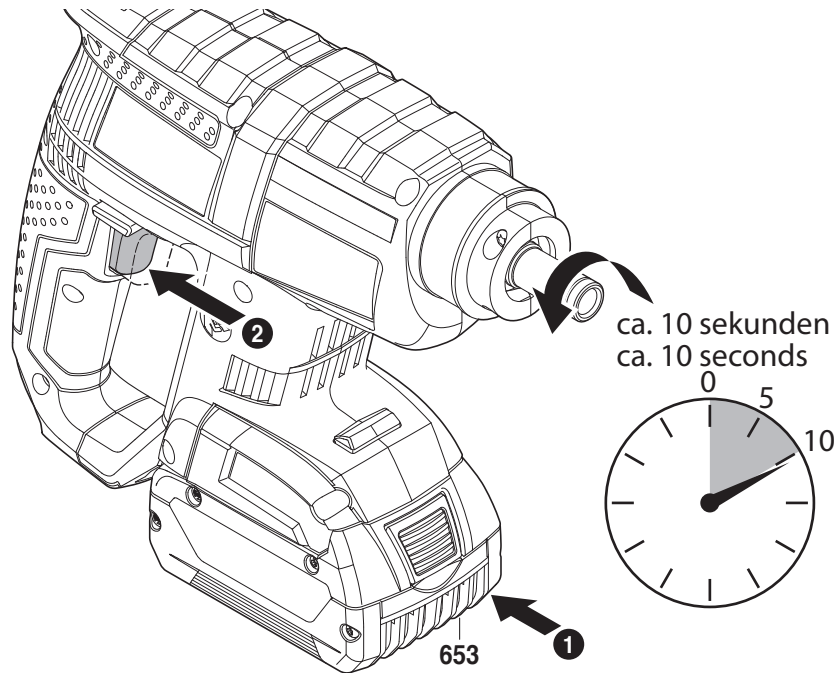

40.

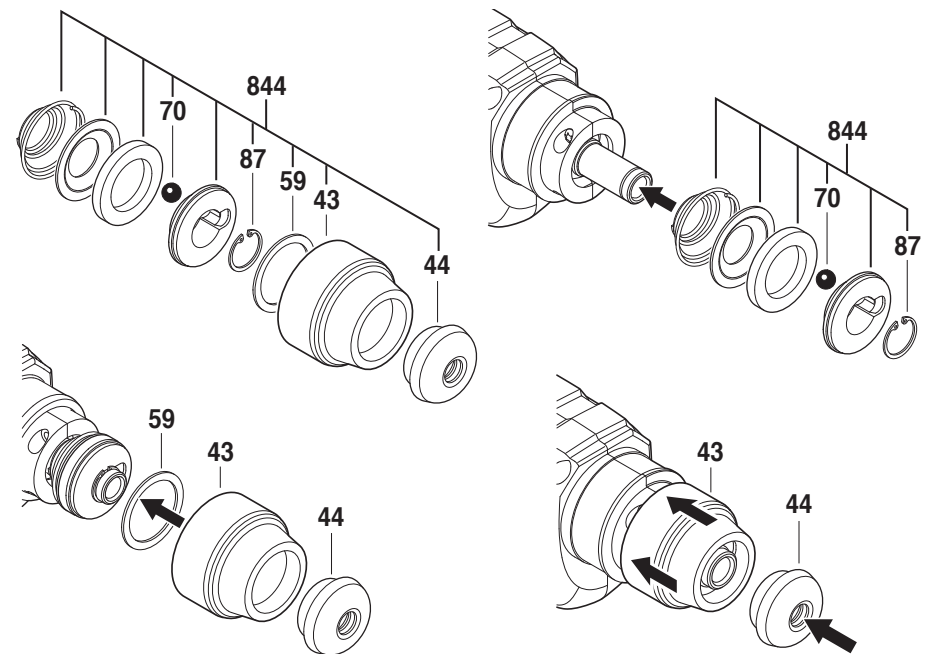

41.

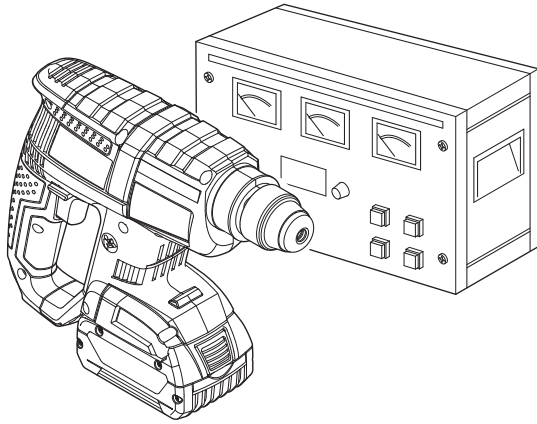

41. Hochspannungsprüfung durchführen.  
**Beachten:**  
Die Sicherheitsvorschriften nach DIN, VDE, CEE, AFNOR und weitere in den einzelnen Ländern gültigen Vorschriften sind einzuhalten.

41. Effectuer un contrôle à haute tension.  
**Attention:**  
Respecter les instructions de sécurité selon DIN, VDE, CEE, AFNOR et les autres instructions valables dans les pays respectifs.

41. Carry out power supply check.  
**Attention:**  
Safety regulations according to DIN, VDE, CEE, AFNOR and further regulations applicable in individual countries must be observed.

41. Efectuar la prueba de alta tensión.  
**Atención:**  
Atenerse a las prescripciones de seguridad según DIN, VDE, CEE, AFNOR y a las prescripciones adicionales específicas que pudieran existir en los respectivos países.

42.

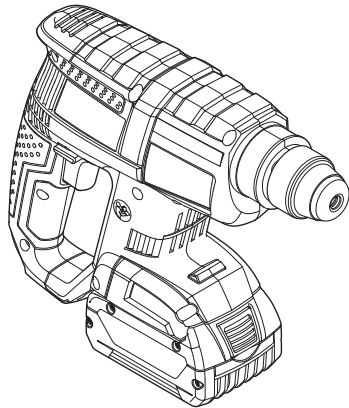

42. Probelauf, Schlagtest, elektrische und mechanische Prüfung durchführen.

42. Marche à titre d'essai, contrôle de frappe et depercage, effectuer un contrôle mécanique et électrique.

42. Perform test run, impact test, electrical and mechanical check-up.

42. Realizar un control funcional, una prueba de taladrado con y sin percusión y los ensayos eléctricos y mecánicos correspondientes.

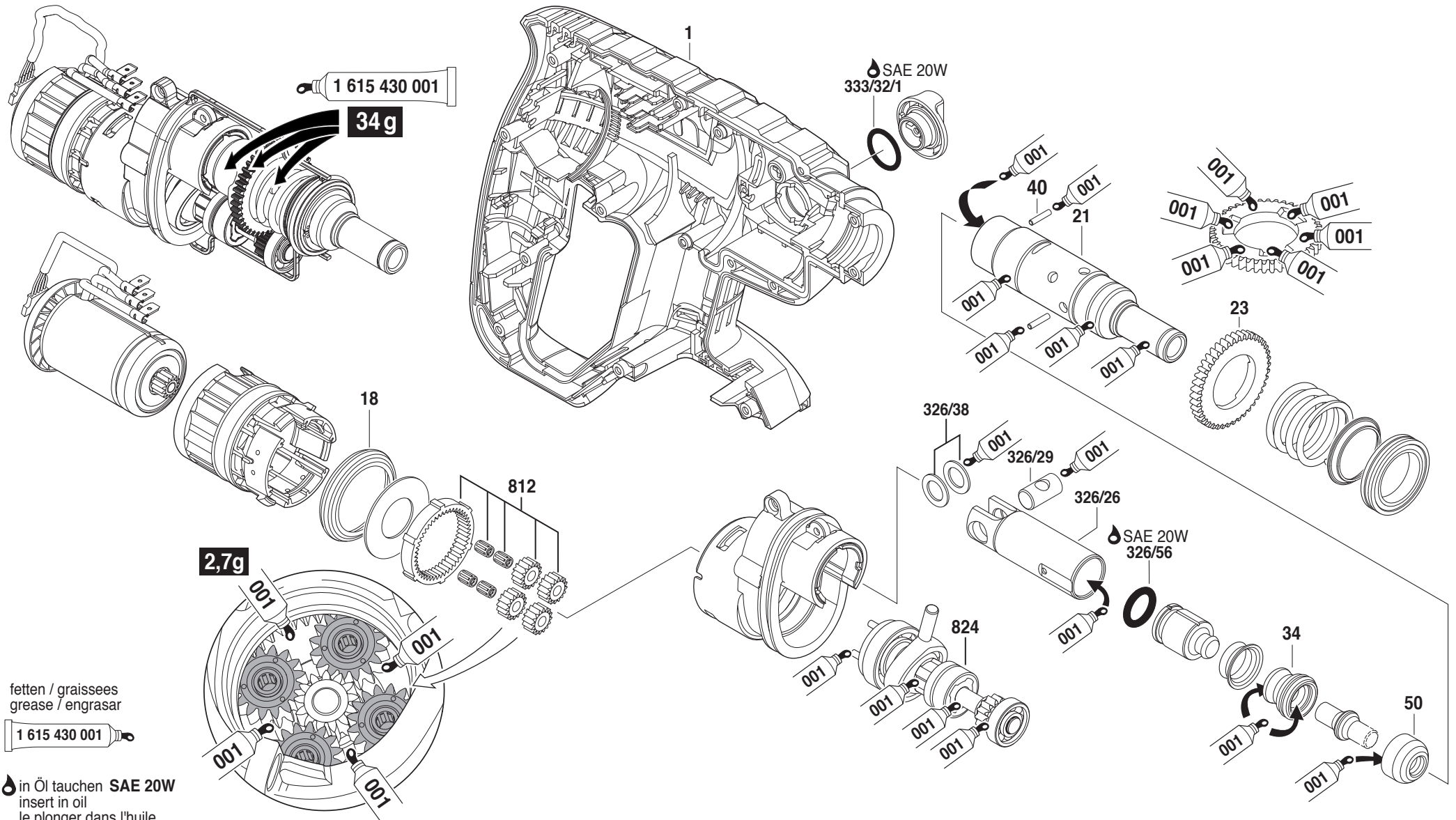

**Achtung:** Hilfswerkzeuge sind dieselben wie für 3 611 J03 R00  
**Attention:** Outils auxiliaire sont la même que celle si 3 611 J03 R00

**Attention:** Auxiliary tools are the same as required for 3 611 J03 R00  
**Attention:** Herramienta auxiliar es la misma que estas 3 611 J03 R00

**a** Hilfswerkzeug zum Selbstanfertigen  
 Auxiliary tool (for your own manufacture)  
 Outil auxiliaire (fabrication locale)  
 Utile (fabricación particular)

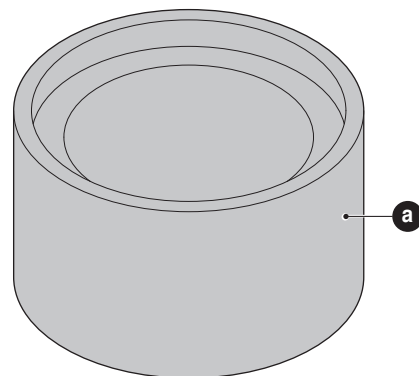
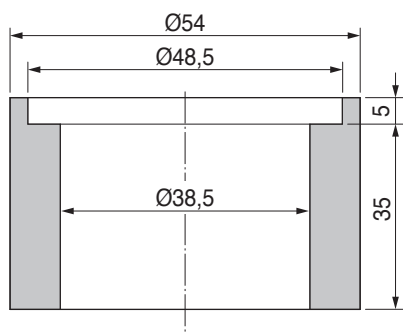

Maße in mm  
 Dimensions in mm  
 Cotes en mm  
 Medidas en mm

Montage

Stützfuß für Pos. 802 (Motoreinheit)

**b** Hilfswerkzeug zum Selbstanfertigen  
 Auxiliary tool (for your own manufacture)  
 Outil auxiliaire (fabrication locale)  
 Utile (fabricación particular)

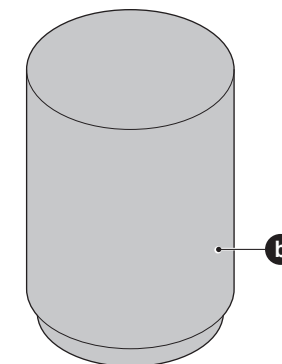
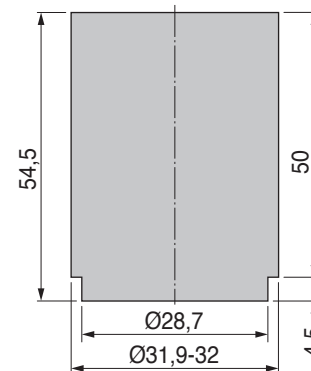

Maße in mm  
 Dimensions in mm  
 Cotes en mm  
 Medidas en mm

Montage

Pos. 802 (Getriebegehäuse) auf Pos. 820 (Motoreinheit) aufpressen

**c** Hilfswerkzeug zum Selbstanfertigen  
 Auxiliary tool (for your own manufacture)  
 Outil auxiliaire (fabrication locale)  
 Utile (fabricación particular)

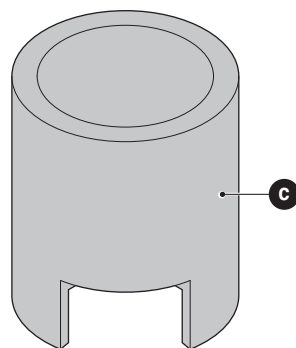
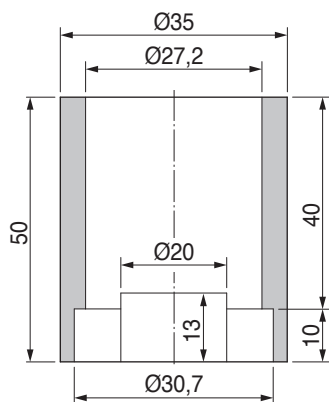

Demontage

Pos. 39 (Sprengring) Demontage. Federentlastung bei Pos. 821 (Hammerrohr)

**d** Hilfswerkzeug zum Selbstanfertigen  
 Auxiliary tool (for your own manufacture)  
 Outil auxiliaire (fabrication locale)  
 Utile (fabricación particular)

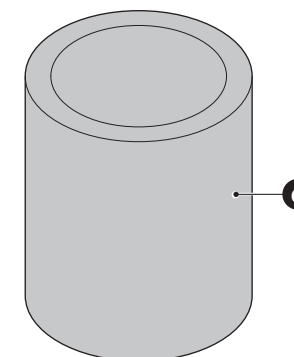
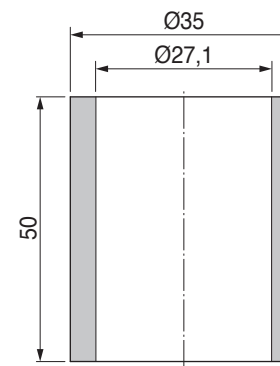

Maße in mm  
 Dimensions in mm  
 Cotes en mm  
 Medidas en mm

Montage

Pos. 39 (Federring) auf Pos. 821 (Hammerrohr) aufpressen