

INSTANDSETZUNGSHINWEISE
REPAIR INSTRUCTIONS
INSTRUCTIONS DE REPARATION
INSTRUCCIONES DE REPARACION



Bohrhammer
Rotary Hammer
Marteau perforateur
Martillo perforador

Typ 3 611 B50 4 . . = GBH 2-23 RE

Änderungen vorbehalten. Unsere Erzeugnisse werden stets dem neuesten technischen Stand angepaßt. Deshalb behalten wir uns Änderungen vor.

Modifications. Our products are constantly modified to meet new technical standards. We therefore reserve the right to alter data and specifications without prior notice.

Modifications. Nos produits sont continuellement adaptés aux dernières nouveautés techniques et les dates sont données sous réserve de changement.

Modificaciones. Nuestros fabricados van siendo adaptos constantemente a las últimas conquistas técnicas. Por ello, tenemos que reservarnos el derecho de introducir modificaciones en los datos técnicos.

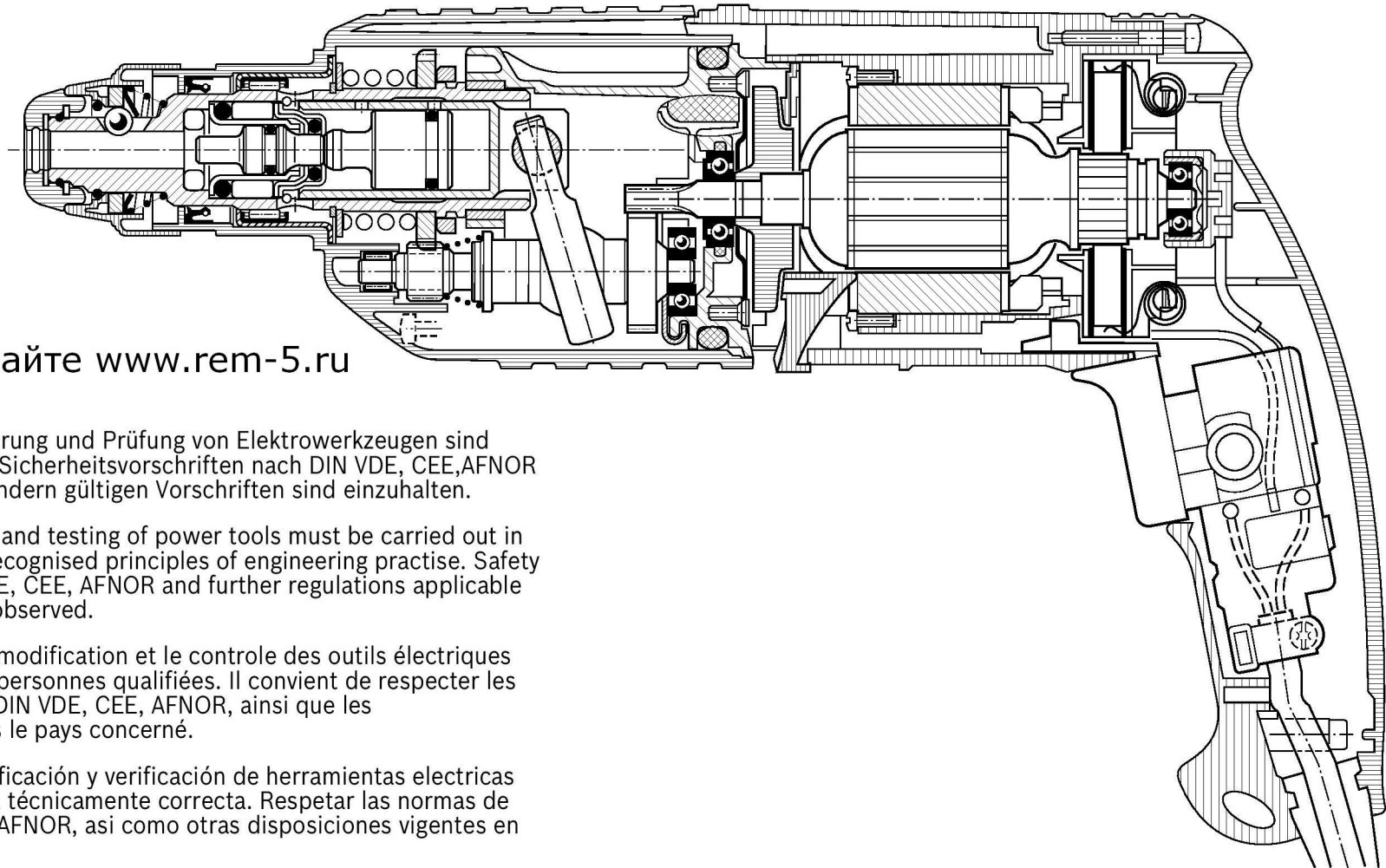

Опубликовано на сайте www.rem-5.ru

Beachten: Instandsetzung, Änderung und Prüfung von Elektrowerkzeugen sind fachgerecht durchzuführen. Die Sicherheitsvorschriften nach DIN VDE, CEE, AFNOR und weitere in den einzelnen Ländern gültigen Vorschriften sind einzuhalten.

Attention: Repair, modification, and testing of power tools must be carried out in accordance with the generally recognised principles of engineering practise. Safety regulations according to DIN VDE, CEE, AFNOR and further regulations applicable in individual countries must be observed.

Attention: La remise en état, la modification et le controle des outils électriques doivent être effectués par des personnes qualifiées. Il convient de respecter les prescriptions de sécurité selon DIN VDE, CEE, AFNOR, ainsi que les réglementations en vigueur dans le pays concerné.

Obsérvese: La reparación, modificación y verificación de herramientas electricas mano debe efectuarse en forma técnicamente correcta. Respetar las normas de seguridad segun DIN VDE, CEE, AFNOR, asi como otras disposiciones vigentes en los distinos paises.

Zerlegen

Für die Demontage werden handelsübliche Werkzeuge benötigt.

1. Eingangsprüfung durchführen.

Beachten:

Die Sicherheitsvorschriften nach DIN, VDE, CEE, AFNOR und weitere in den einzelnen Ländern gültigen Vorschriften sind einzuhalten.

Disassembly

Use normal trade tools by disassembly.

1. Carry out power supply check.

Attention:

Safety regulations according to DIN, VDE, CEE, AFNOR and further regulations applicable in individual countries must be observed.

Démontage

Pour le démontage, des outils en usage dans le commerce sont nécessaires.

1. Effectuer un contrôle préliminaire.

Attention:

Respecter les instructions de sécurité selon DIN, VDE, CEE, AFNOR et les autres instructions valables dans les pays respectifs.

Desmontaje

Para el desmontaje no se precisan herramientas especiales.

1. Realizar control de recepción.

Atención:

Atenerse a las prescripciones de seguridad según DIN, VDE, CEE, AFNOR y a las prescripciones adicionales específicas que pudieran existir en los respectivos países.

1.

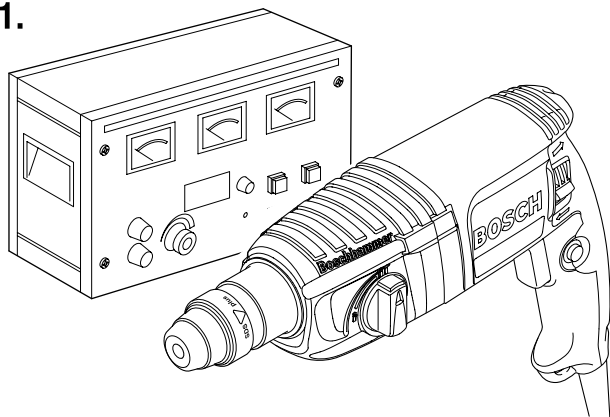

2.

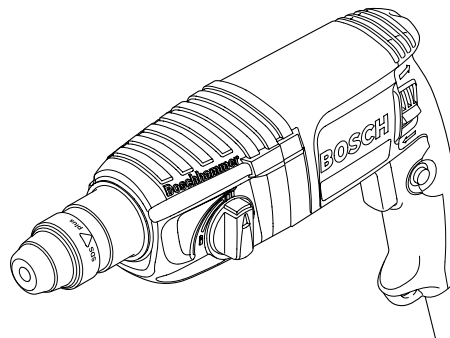

2. Zerlegen nach Explosions-, Schnittzeichnung und diesem Instandsetzungshinweis.
2. Disassembly using explosion, cut-away drawings and these repair instructions!
2. Démontez l'appareil suivant la vue éclatée, le plan en coupe et ces instructions de réparation.
2. Realizar el desmontaje conforme a los dibujos en perspectiva y en sección, y a estas instrucciones de reparación.

3.

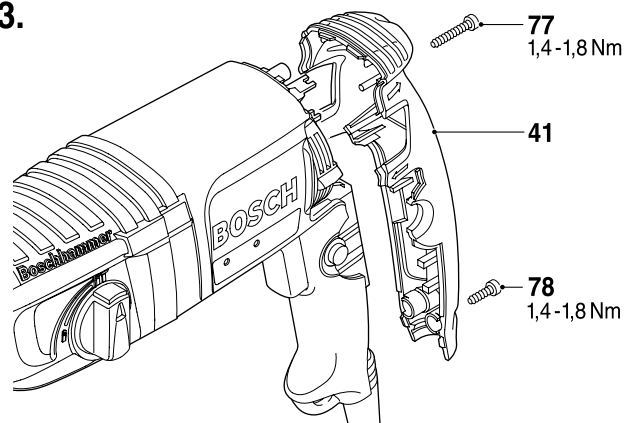

3.1

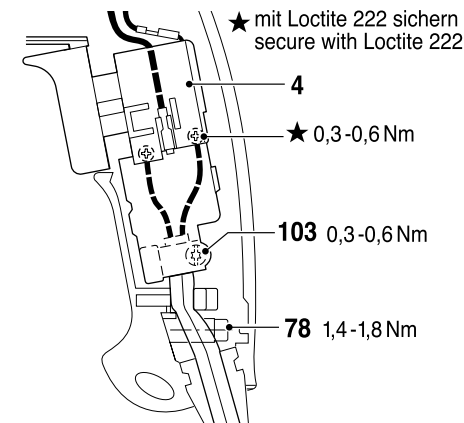
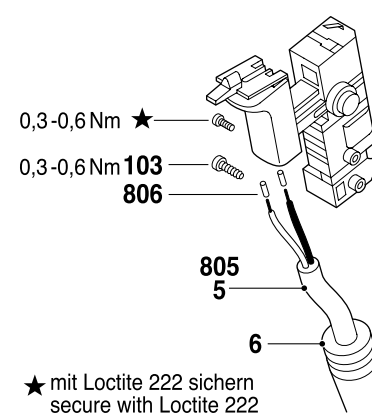
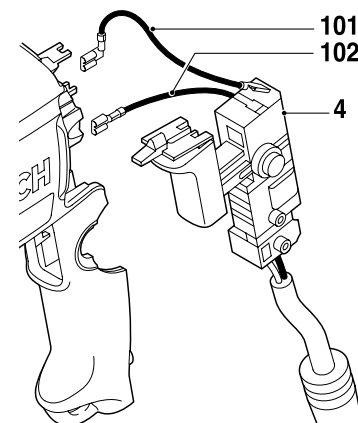

3.2

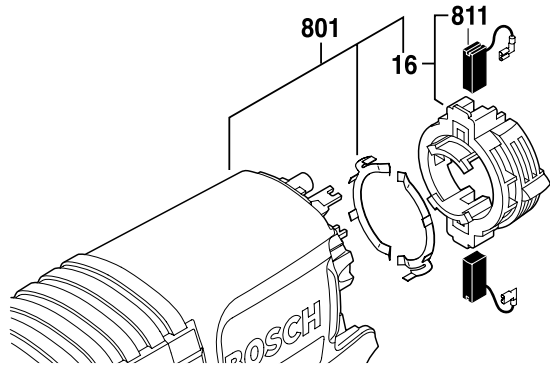

4.

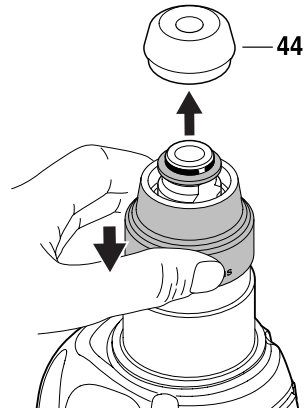

4.1

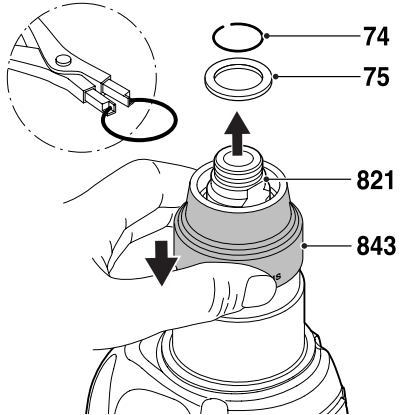

4.2

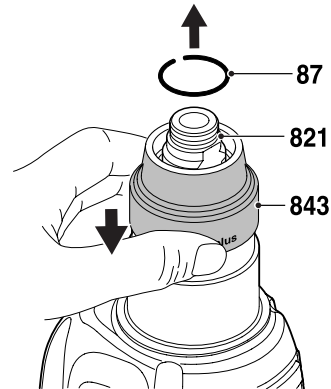

4.3

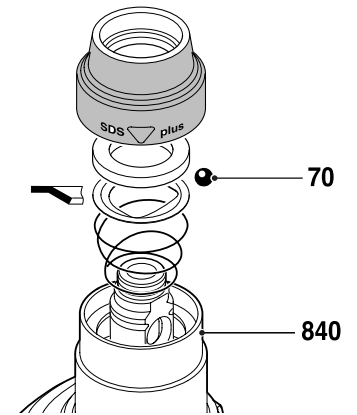

5.

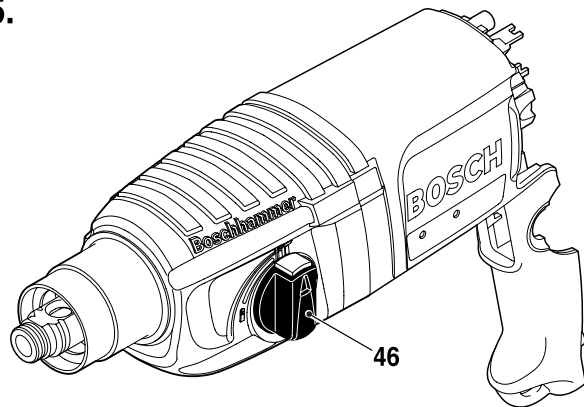

5.1

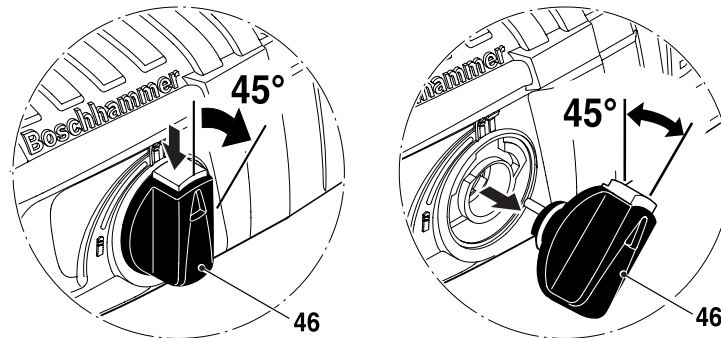

5.2

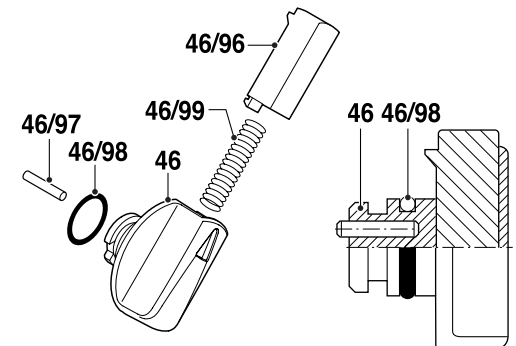

5.3

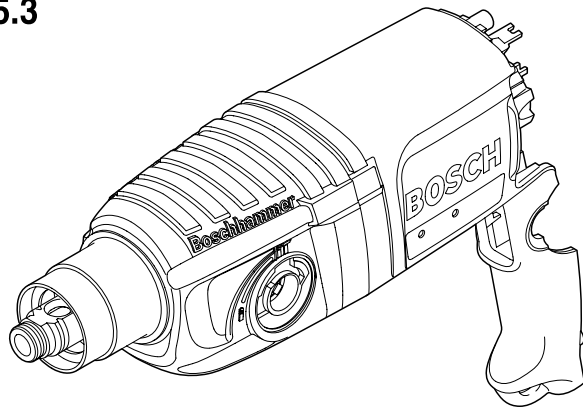

5.4

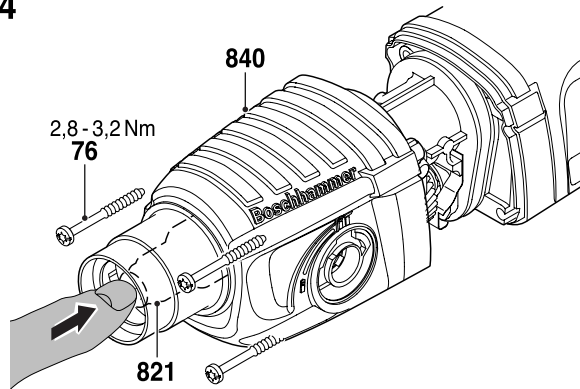

5.5

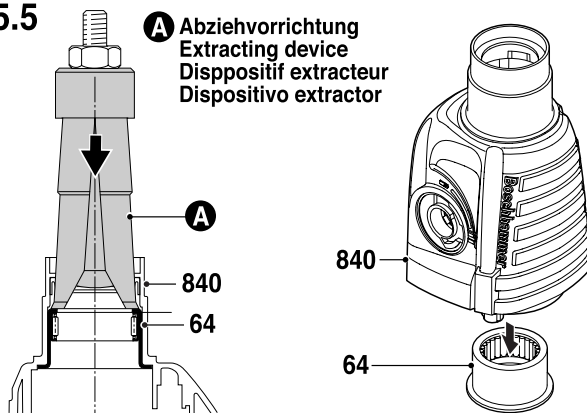

5.6

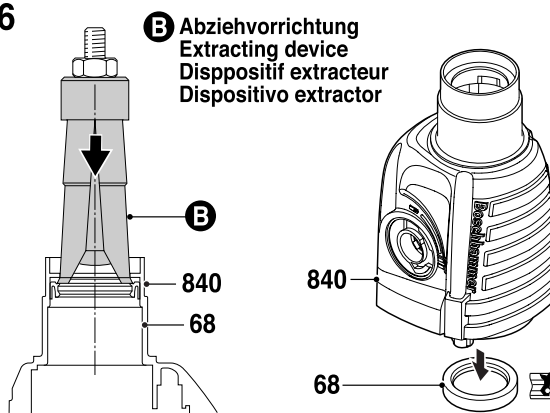

5.7

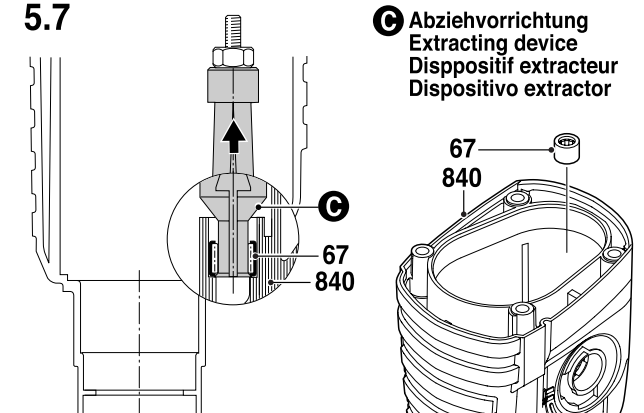

6.

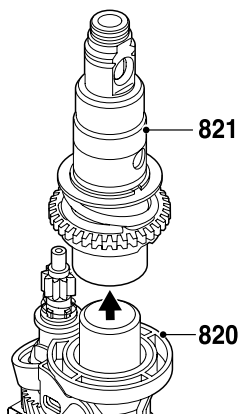

6.1

Ausrastmoment der Sicherheitskupplung prüfen
Check release torque of safety clutch.
Controler le moment de désaccouplement
de l'accouplement de sécurité.
Comprobar el par de desenclavamiento
del embrague de seguridad

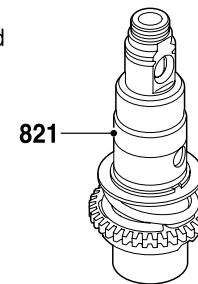

6.2

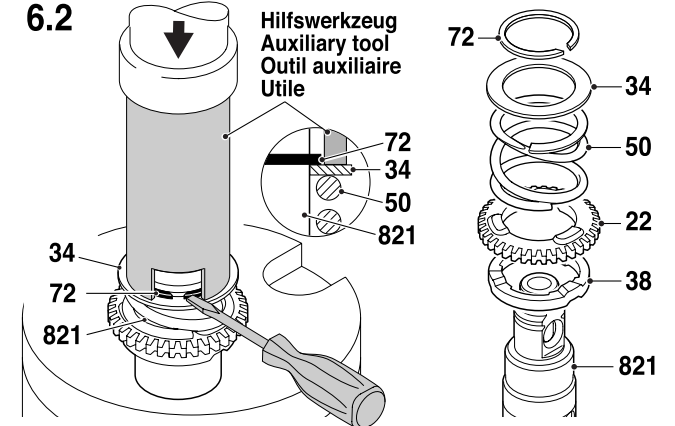

6.3

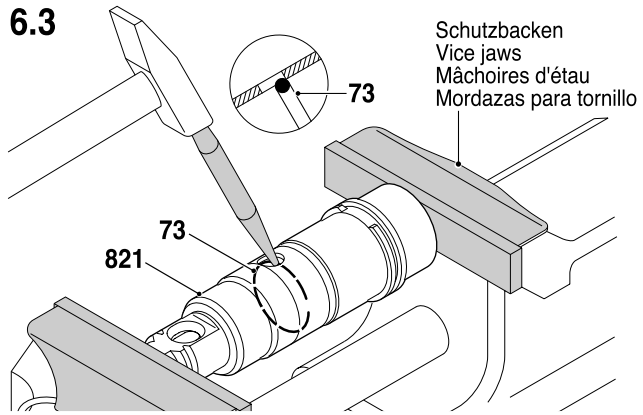

6.4

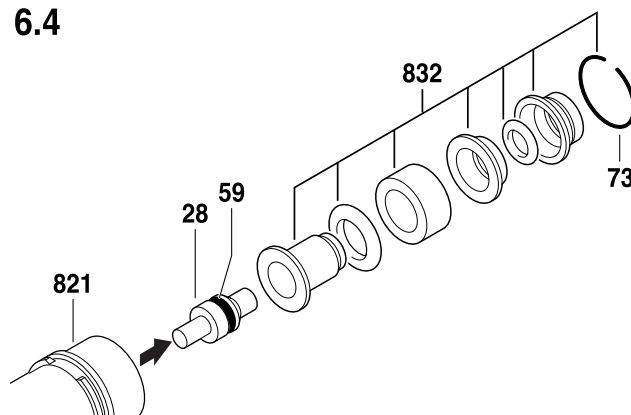

6.5

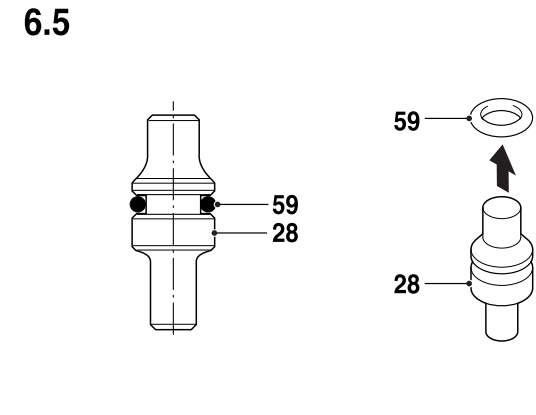

6.6

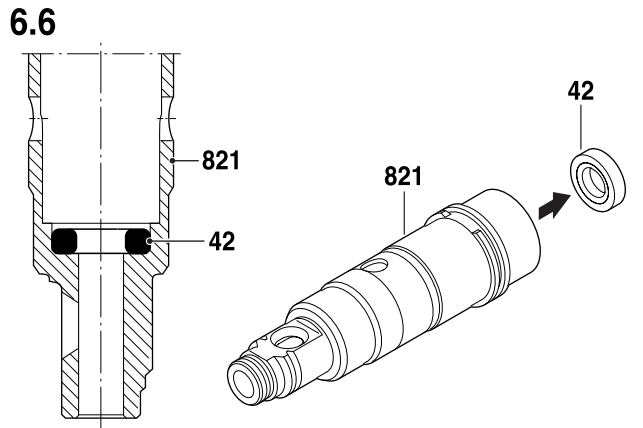

7.

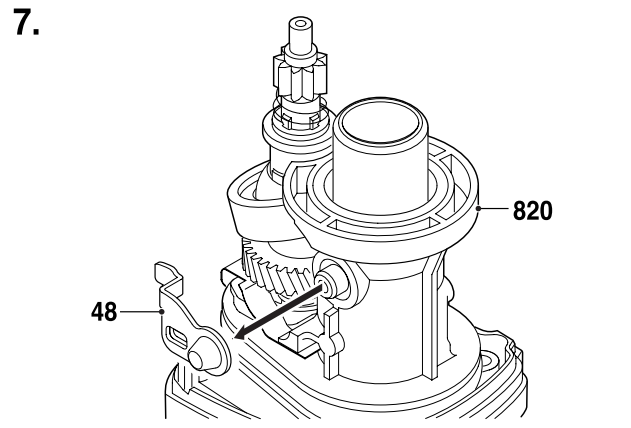

7.1

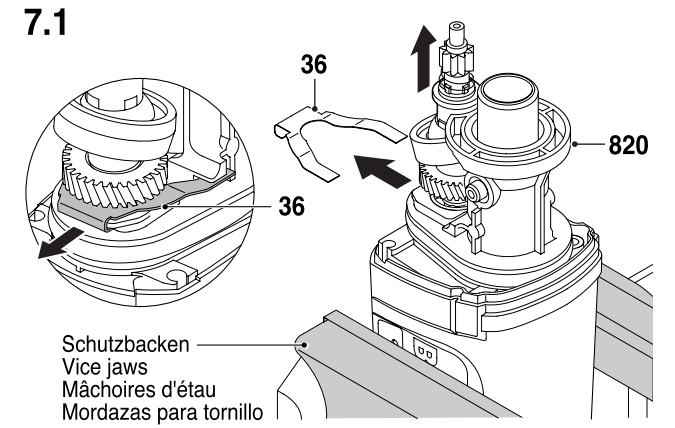

7.2

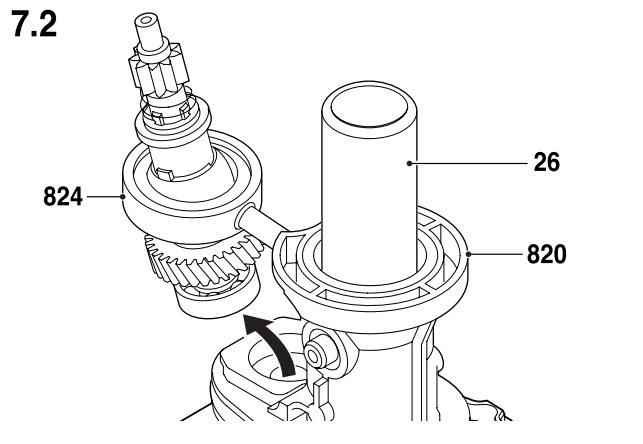

7.3

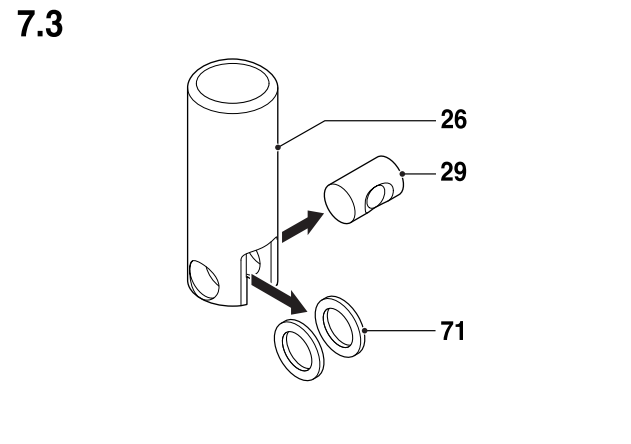

7.4

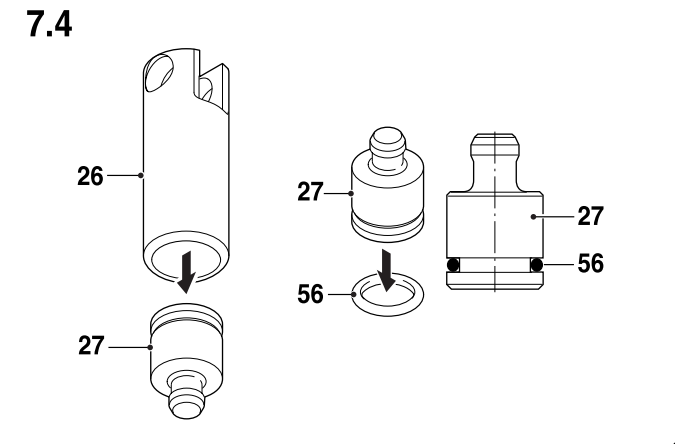

7.5

Montagedorn
Mounting pin
Arbre de montage
Punzón de montaje

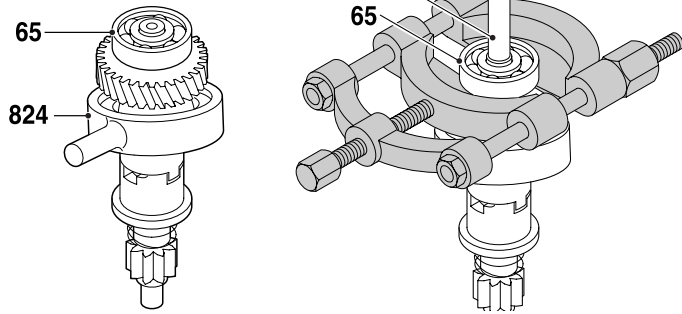

8.

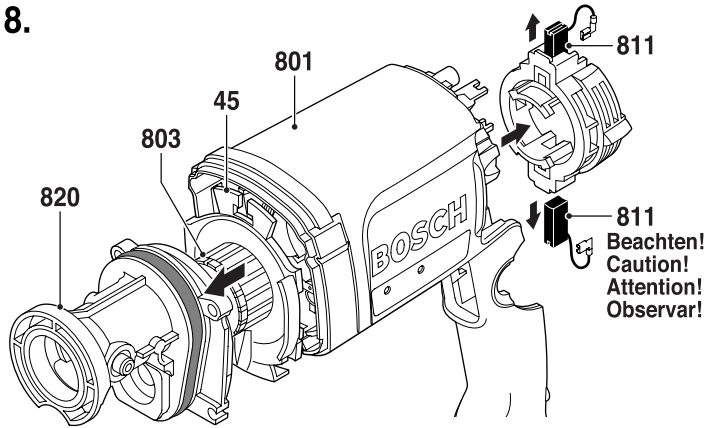

8.1

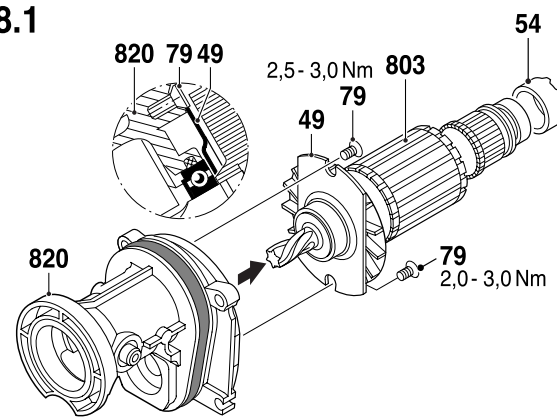

8.2

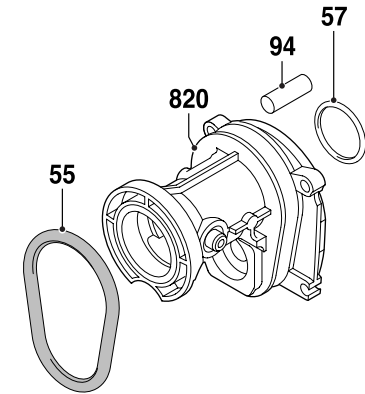

8.3

Abziehvorrichtung
Extracting device
Dispositif extracteur
Dispositivo extractor

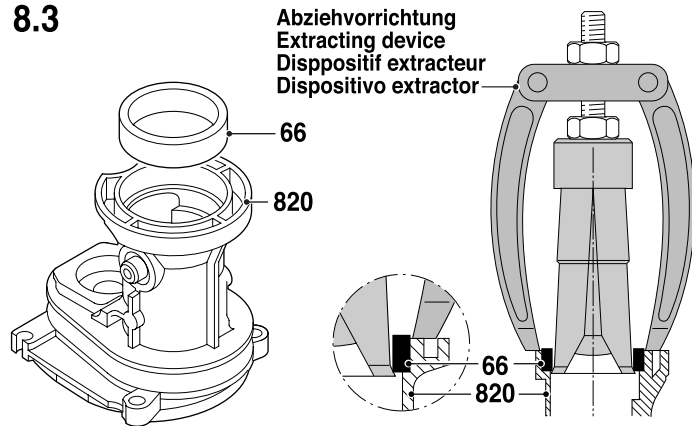

8.4

Abziehvorrichtung
Extracting device
Dispositif extracteur
Dispositivo extractor

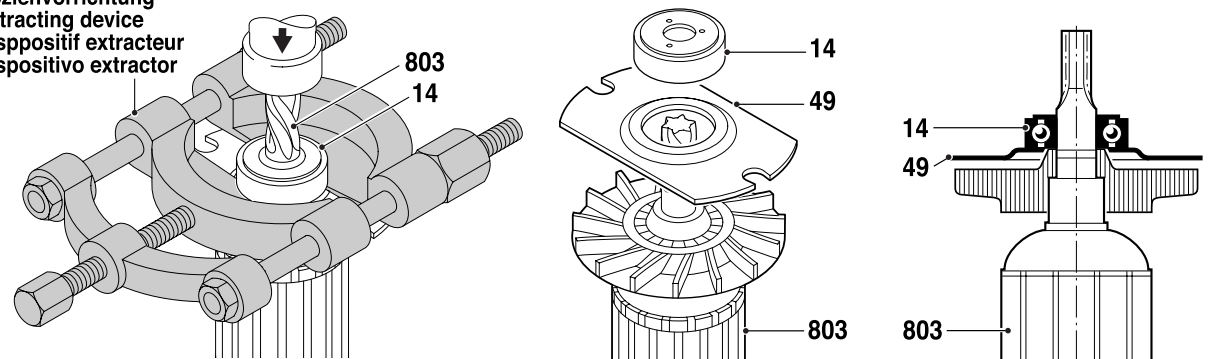

8.5

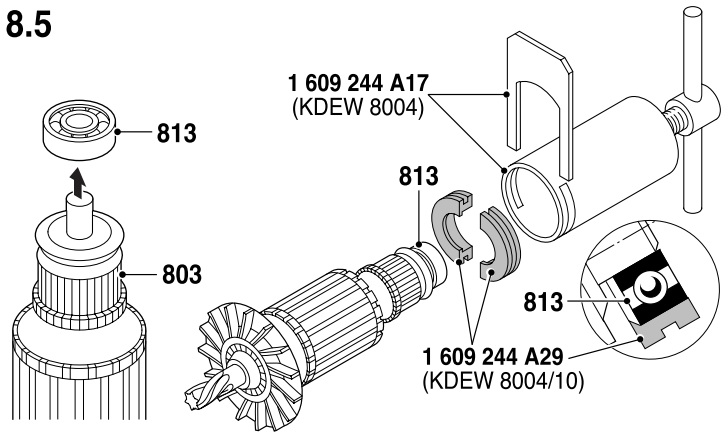

8.6

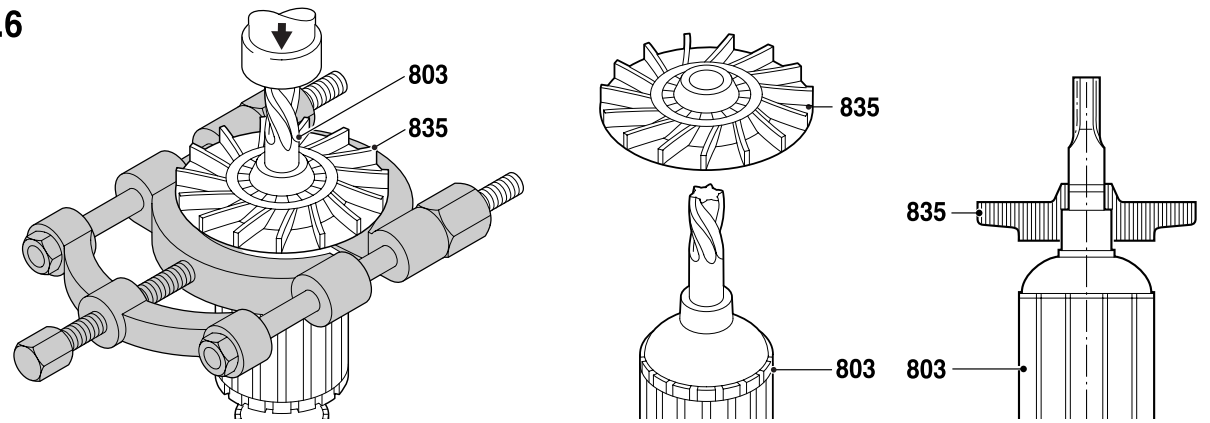

9.

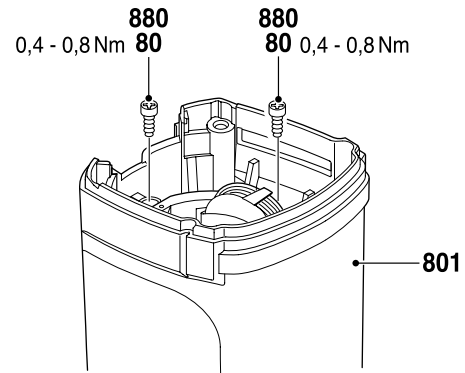

9.1

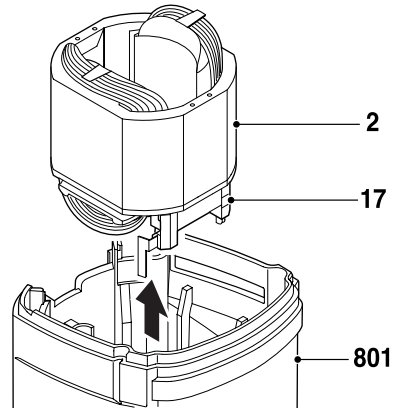

9.2

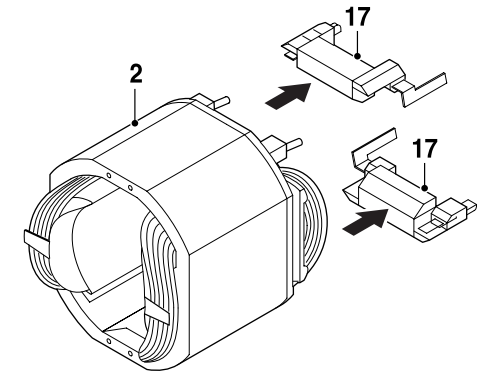

Zusammenbau

Montage nach Explosionszeichnung und diesem Instandsetzungshinweis.

Alle Teile sind gereinigt, abgenutzte und beschädigte Teile werden ersetzt.

Nur Original-Ersatzteile verwenden.

Zähne aller Zahnräder mit Fett **1 615 430 001** bestreichen.

Bitte Schmierhinweise beachten!

Assembly

Assembly using explosion drawings and these repair instructions!

Clean all parts, replace worn-out and damaged parts.

Use only original spare parts!

Grease all gear teeth **1 615 430 001**.

Please note lubrication instructions!

Montage

Le montage s'effectue selon la vue éclatée et les instructions de réparation suivantes.

Toutes les pièces sont nettoyées, les pièces usées ou endommagées doivent être remplacées par des nouvelles. Pour le remplacement de pièces, n'utiliser que des pièces d'origine.

Les dents graisser **1 615 430 001**.

Respecter les instructions de graissage!

Montaje

Realizar el montaje conforme a los dibujos en perspectiva y a estas instrucciones de reparación.

Todas las piezas deben estar limpias. Las piezas desgastadas o danadas deben reemplazarse por piezas nuevas. Utilizar solamente piezas de repuesto originales.

Dientes engrasar **1 615 430 001**.

Observar las instrucciones de lubricación!

21.

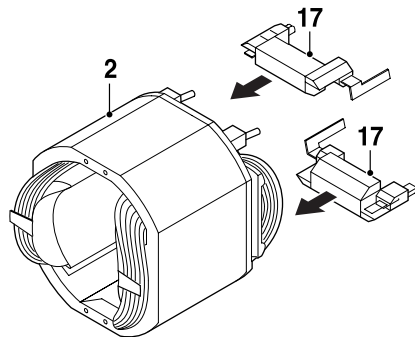

21.1

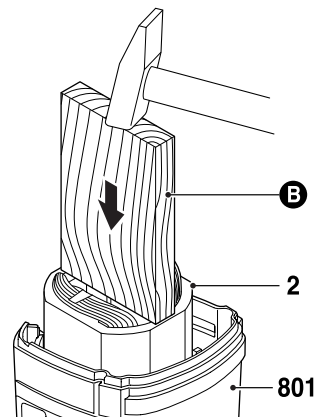

B Hilfswerkzeug zum Selbstanfertigen
Auxiliary tool (for your own manufacture)
Outil auxiliaire (fabrication locale)
Utile (fabricación particular)

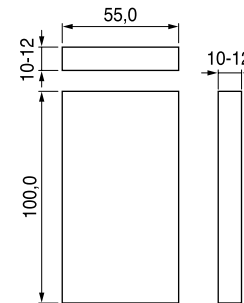

Maße in mm
Dimensions in mm
Cotes en mm
Medidas en mm

21.2

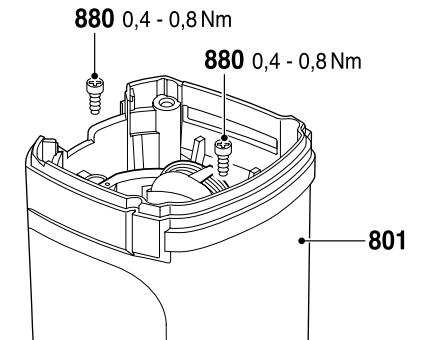

22.

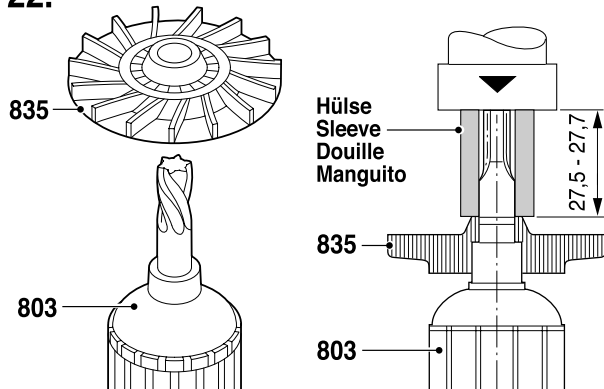

Einbaumaß beachten!
Observe correct installation tolerance!
Attention à la cote de montage!
Obsérvese la medida de montaje!

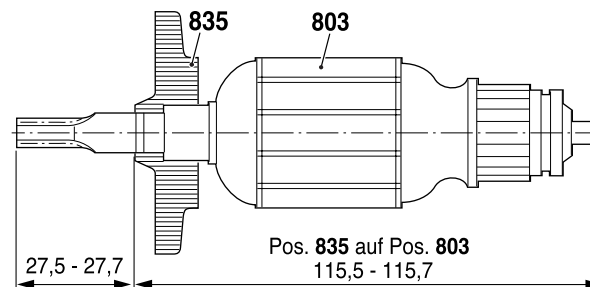

22.2

sofern ungefettet
if unlubricated
si n'est pas graisse
si no engrasado

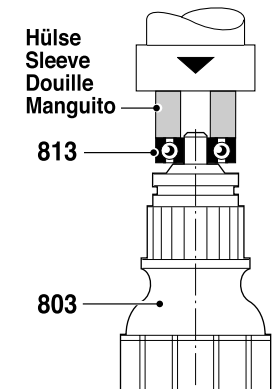
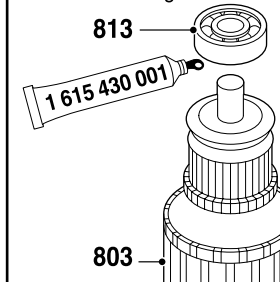

22.3

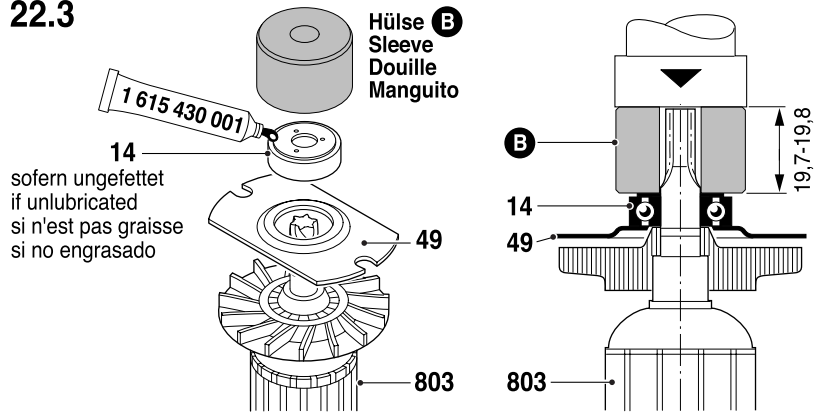

14
sofern ungefettet
if unlubricated
si n'est pas graisse
si no engrasado

Hülse **B**
Sleeve
Douille
Manguito

Hilfswerkzeug zum Selbstanfertigen
Auxiliary tool (for your own manufacture)
Outil auxiliaire (fabrication locale)
Utile (fabricación particular)

Hülse **B**
Sleeve
Douille
Manguito

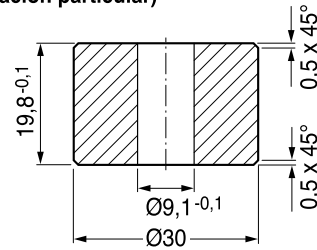

Maße in mm / Dimensions in mm
Cotes en mm / Medidas en mm

23.

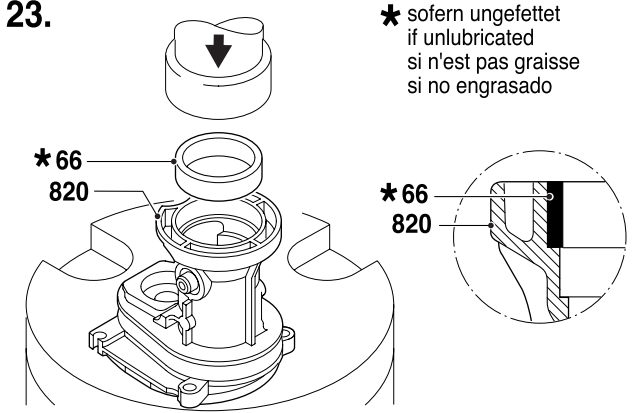

* sofern ungefettet
if unlubricated
si n'est pas graisse
si no engrasado

* 66
820

* 66
820

23.1

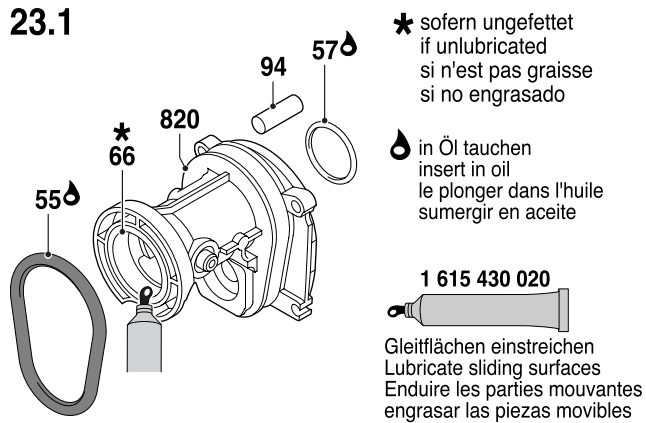

* sofern ungefettet
if unlubricated
si n'est pas graisse
si no engrasado

in Öl tauchen
insert in oil
le plonger dans l'huile
sumergir en aceite

1 615 430 020

Gleitflächen einstreichen
Lubricate sliding surfaces
Enduire les parties mouvantes
engrasar las piezas movibles

23.2

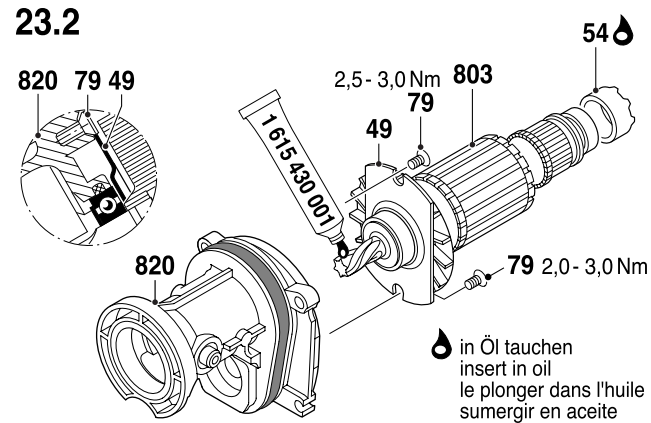

in Öl tauchen
insert in oil
le plonger dans l'huile
sumergir en aceite

23.3

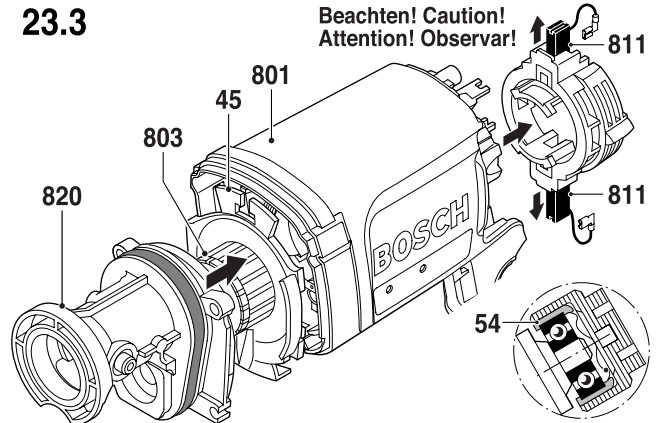

Beachten! Caution!
Attention! Observar!

24.

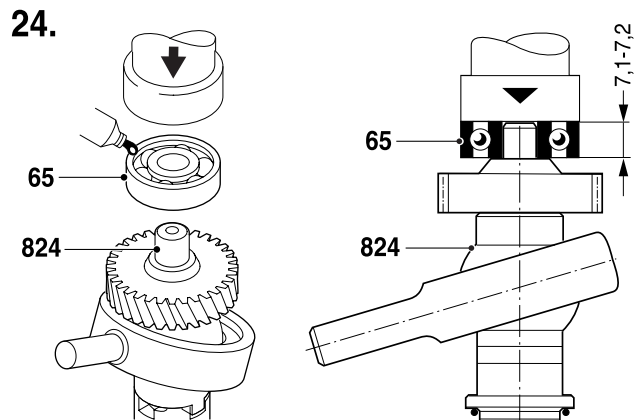

24.1

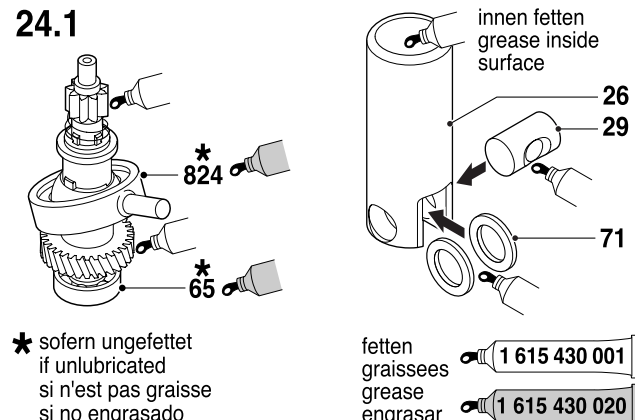

* sofern ungefettet
if unlubricated
si n'est pas graisse
si no engrasado

innen fetten
grease inside
surface

fetten
graissees
grease
engrasar

24.2

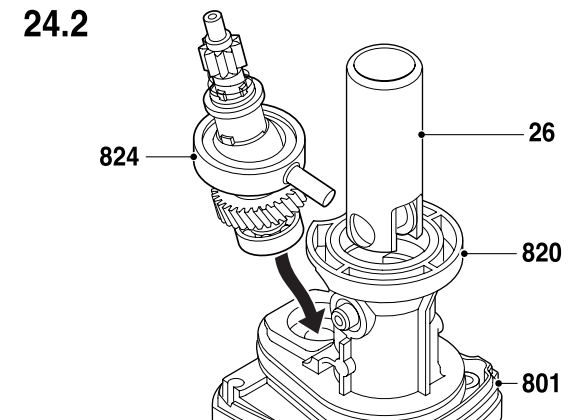

24.3

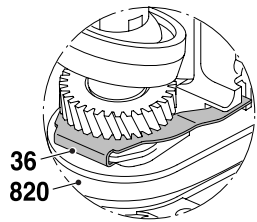

Einbaulage beachten
Check installation position
Attention au positionnement
Téngase en cuenta
la posición de montaje

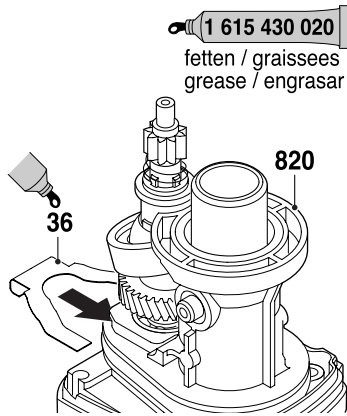

1 615 430 020
 fetten / graissées
 grease / engrasar

24.4

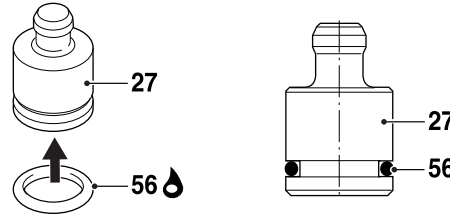

in Öl tauchen
 insert in oil
 le plonger dans l'huile
 sumergir en aceite

24.5

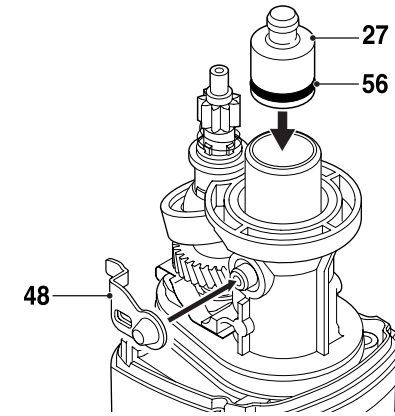

25.

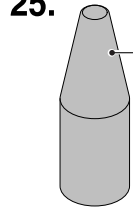

Montagedorn
Mounting pin
Arbre de montage
Punzón de montaje

in Öl tauchen
 insert in oil
 le plonger dans l'huile
 sumergir en aceite

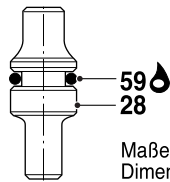
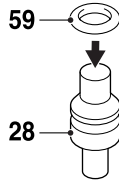

Maße in mm
 Dimensions in mm

Montagedorn
Mounting pin
Arbre de montage
Punzón de montaje

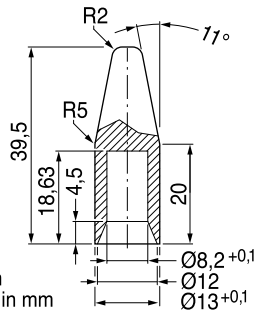

25.1

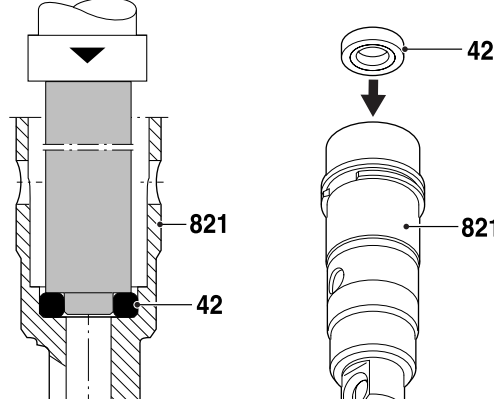

25.2

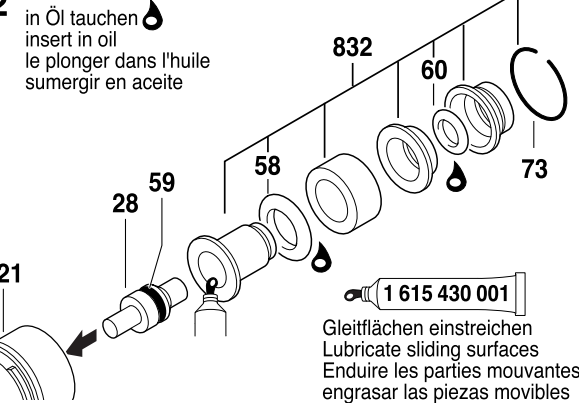

in Öl tauchen
 insert in oil
 le plonger dans l'huile
 sumergir en aceite

1 615 430 001
 Gleitflächen einstreichen
 Lubricate sliding surfaces
 Enduire les parties mouvant
 engrasar las piezas móviles

25.3

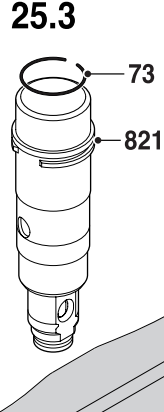

Einbaulage beachten
Check installation position
Attention au positionnement
Téngase en cuenta
la posición de montaje

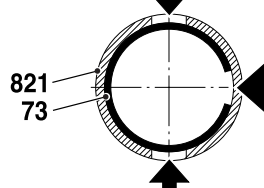

Spreng-Öffnung muß zwischen
den beiden Bohrungen liegen.
Retaining spring gap must lie
between the two bore-holes.

25.4 Hilfswerkzeug / Auxiliary tool

Pos. 26
alter Kolben
old piston
ancien
vieja

Schutzbacken
Vice jaws
Mâchoires d'étau
Mordazas para
tornillo

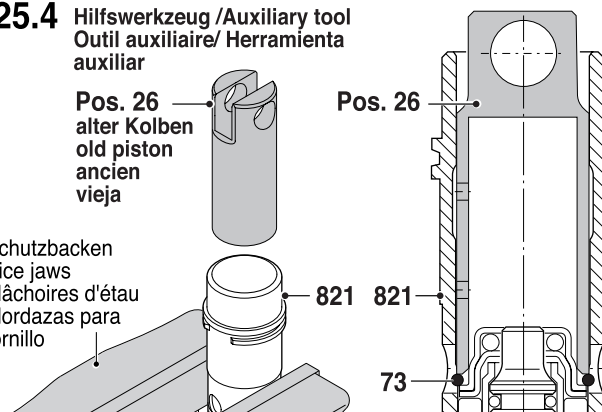

Hilfswerkzeug zum Selbst-
anfertigen / Auxiliary tool
(for your own manufacture)
Outil auxiliaire
(fabrication locale)
Utile (fabricación particular)

Montagedorn D
Mounting pin
Arbre de montage
Punzón de montaje

Maße in mm
 Dimensions in mm
 Cotes en mm
 Medidas en mm

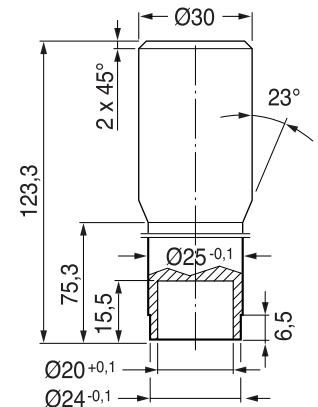

25.5

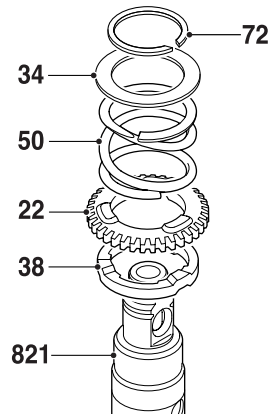

25.6

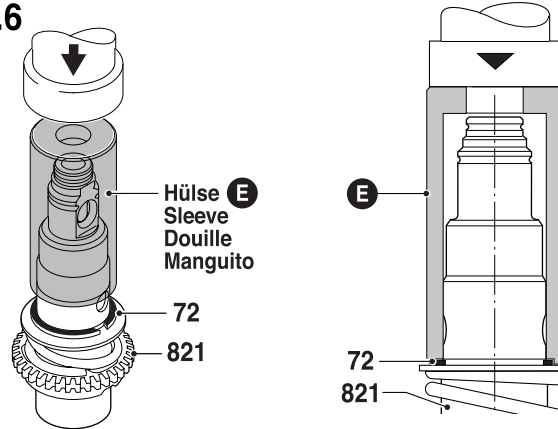

Hilfswerkzeug zum Selbstanfertigen / Auxiliary tool (for your own manufacture)
Outil auxiliaire (fabrication locale)
Utile (fabricación particular)

Hülse **E**
Sleeve
Douille
Manguito

Maße in mm
Dimensions in mm
Cotes en mm
Medidas en mm

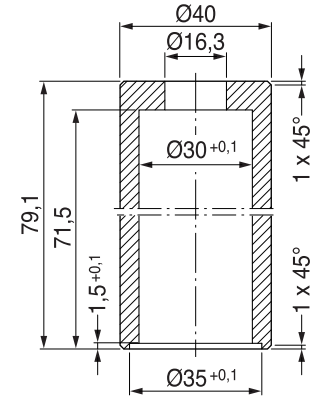

26.

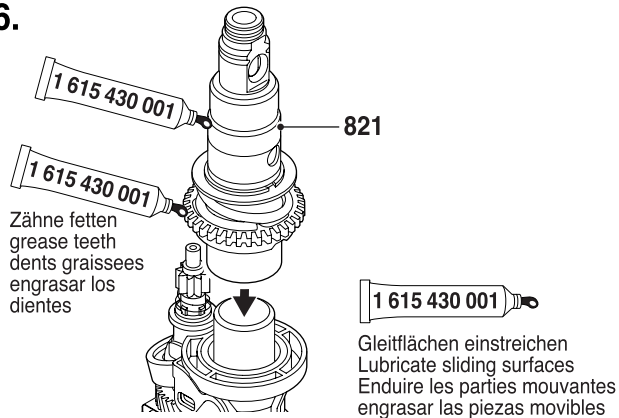

26.1

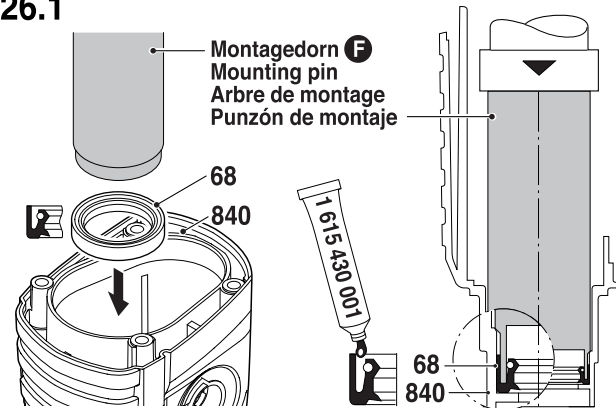

Hilfswerkzeug zum Selbstanfertigen / Auxiliary tool (for your own manufacture)
Outil auxiliaire (fabrication locale)
Utile (fabricación particular)

Montagedorn **F**
Mounting pin
Arbre de montage
Punzón de montaje

Maße in mm
Dimensions in mm
Cotes en mm
Medidas en mm

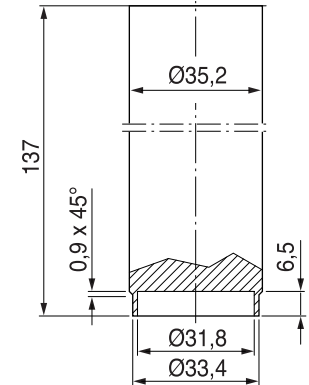

26.2

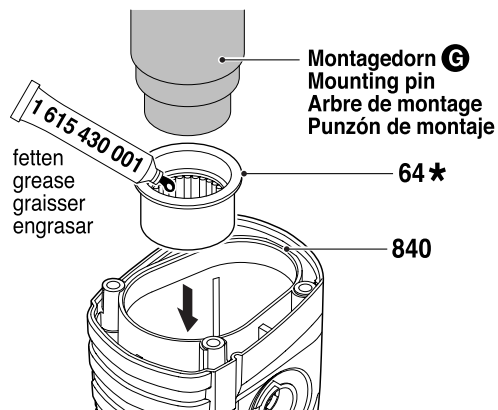

* sofern ungefettet
if unlubricated
si n'est pas graisse
si no engrasado

Montagedorn **G**
Mounting pin
Arbre de montage
Punzón de montaje

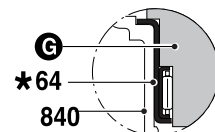

26.3

Hilfswerkzeug zum Selbstanfertigen / Auxiliary tool (for your own manufacture)
Outil auxiliaire (fabrication locale)
Utile (fabricación particular)

Montagedorn **G**
Mounting pin
Arbre de montage
Punzón de montaje

Maße in mm
Dimensions in mm
Cotes en mm
Medidas en mm

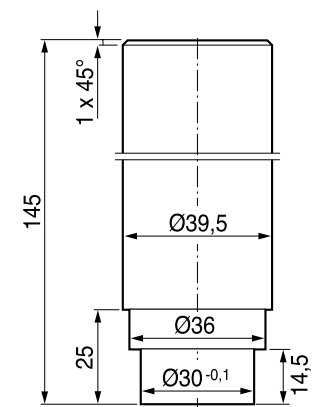

26.4

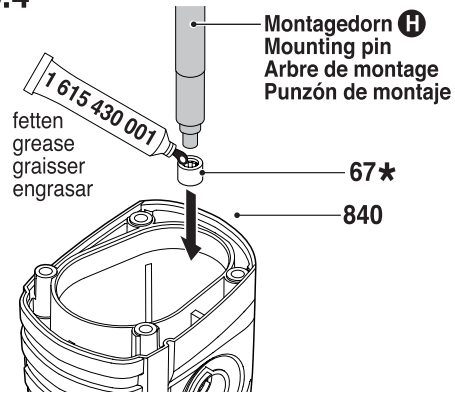

* sofern ungefettet
 if unlubricated
 si n'est pas graisse
 si no engrasado

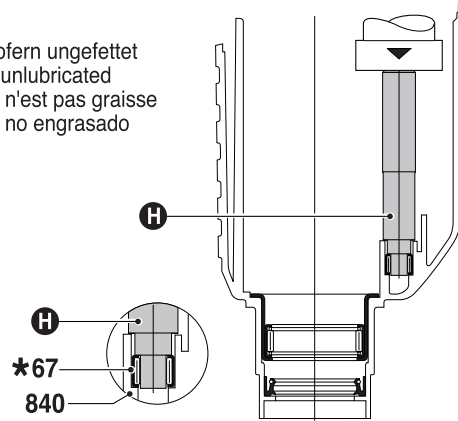

26.5

**Hilfswerkzeug zum Selbst-
 anfertigen / Auxiliary tool
 (for your own manufacture)**
**Outil auxiliaire
 (fabrication locale)**
Utile (fabricación particular)

Montagedorn H
Mounting pin
Arbre de montage
Punzón de montaje

Maße in mm
 Dimensions in mm
 Cotes en mm
 Medidas en mm

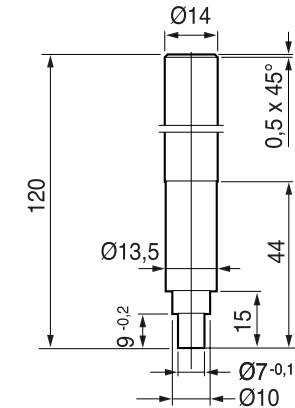

27. Teile fetten (35 g); Rest in Getrieberaum Pos. 840.
 Grease the parts (35 g); rest into gear compartment pos. 840.
 Graisser les pieces (35 g); la graisse restante dans le
 compartiment d'engrenage 840.
 Engrasar las piezas (35 g); resto en el
 compartimento del engranaje pos. 840.

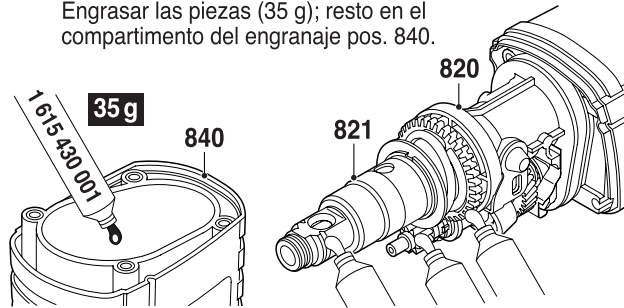

27.1

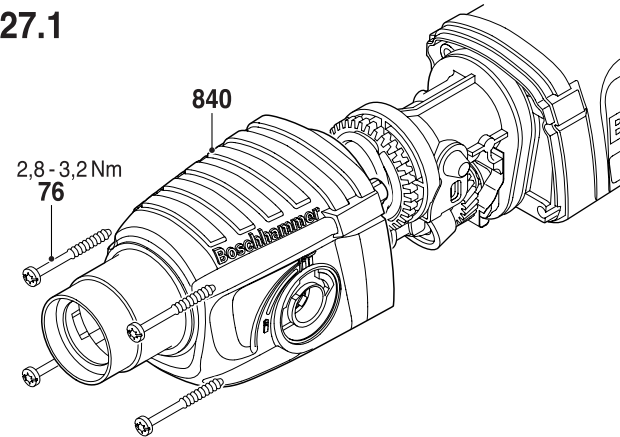

27.2

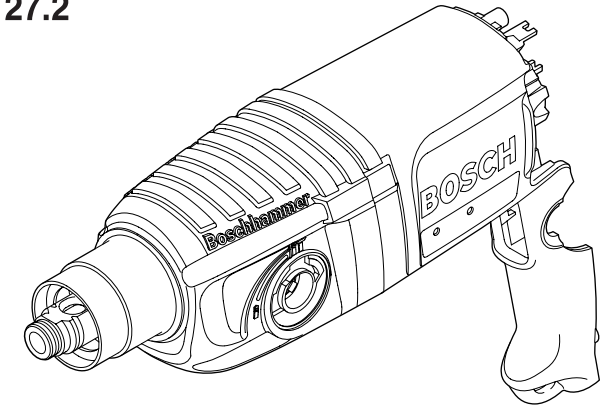

27.

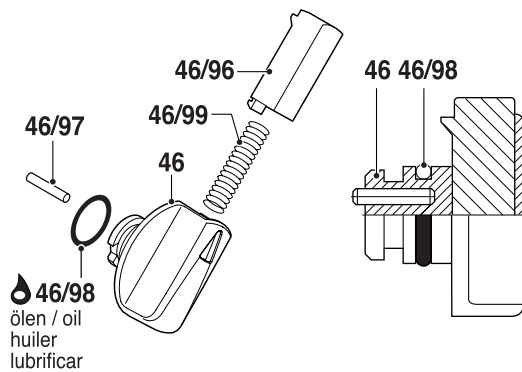

27.1

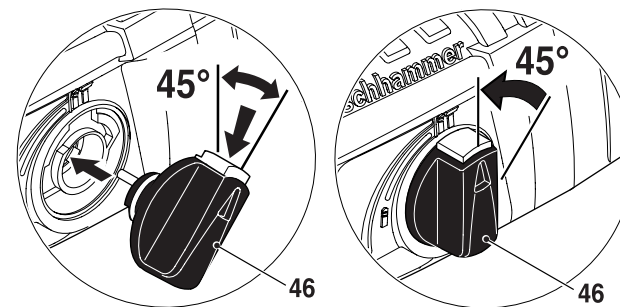

27.2

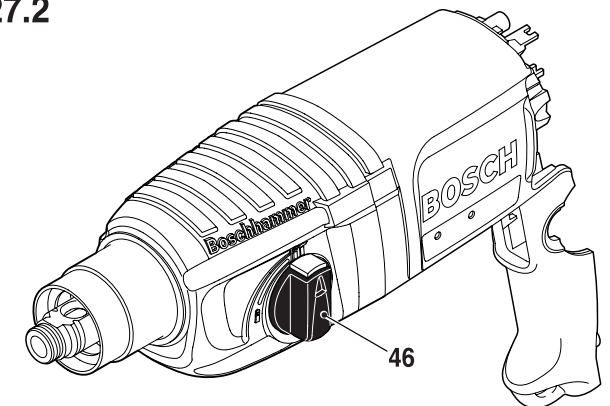

28.

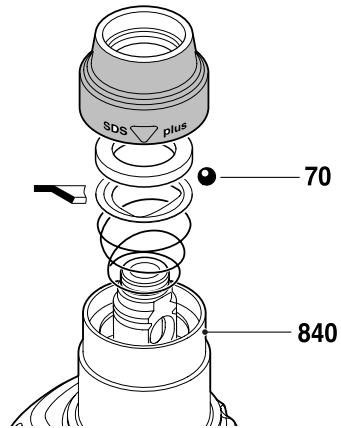

28.1

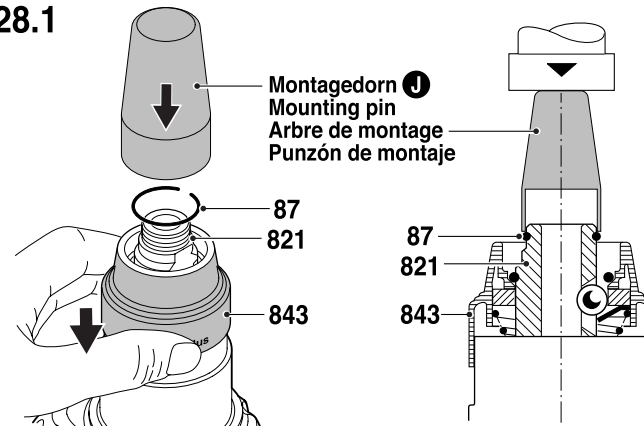

Hilfswerkzeug zum Selbstanfertigen
Auxiliary tool (for your own manufacture)
Outil auxiliaire (fabrication locale)
Utile (fabricación particular)

Montagedorn Ⓡ
Mounting pin
Arbre de montage
Punzón de montaje

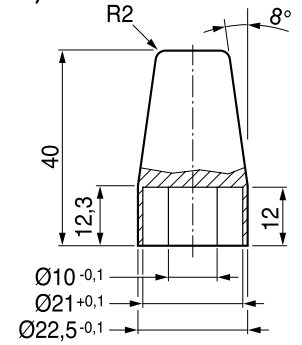

Maße in mm
Dimensions in mm
Cotes en mm
Medidas en mm

28.2

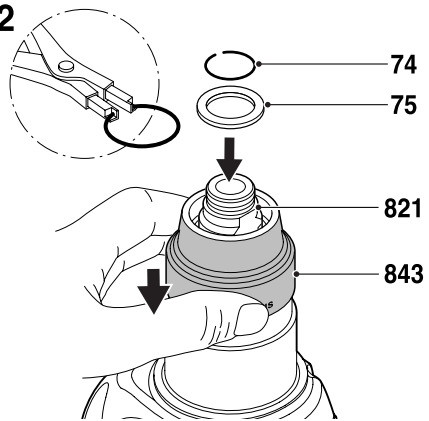

28.3

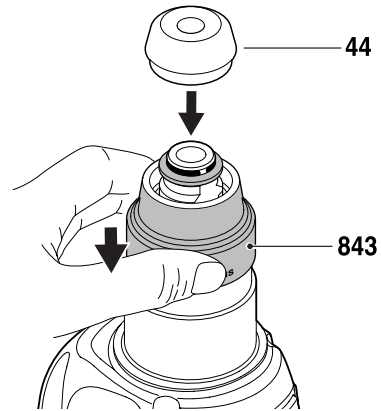

29.

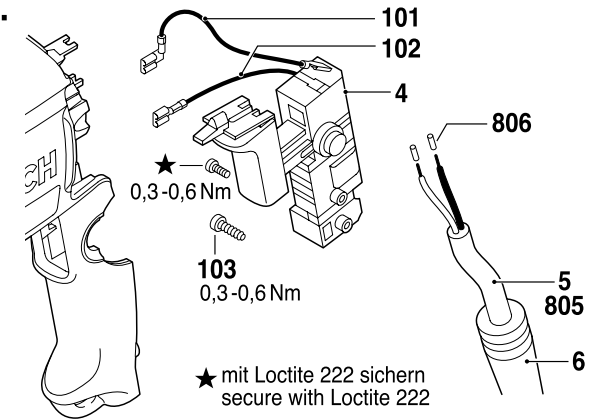

29.1

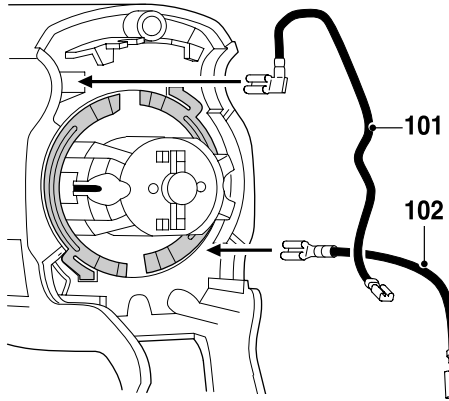

29.2

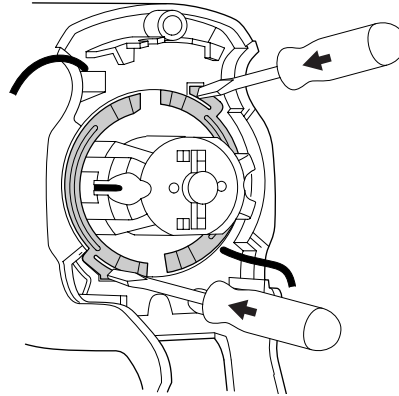

29.3

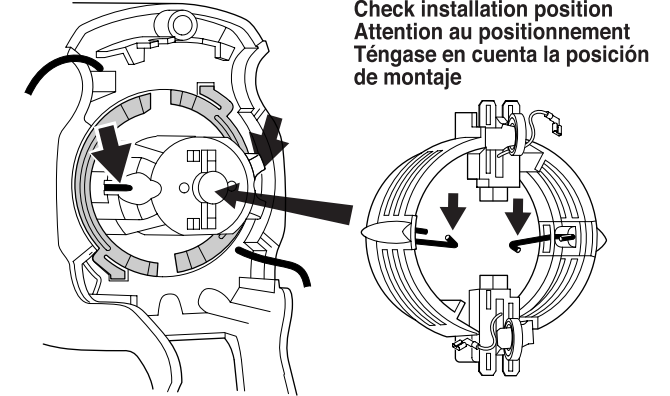

29.4

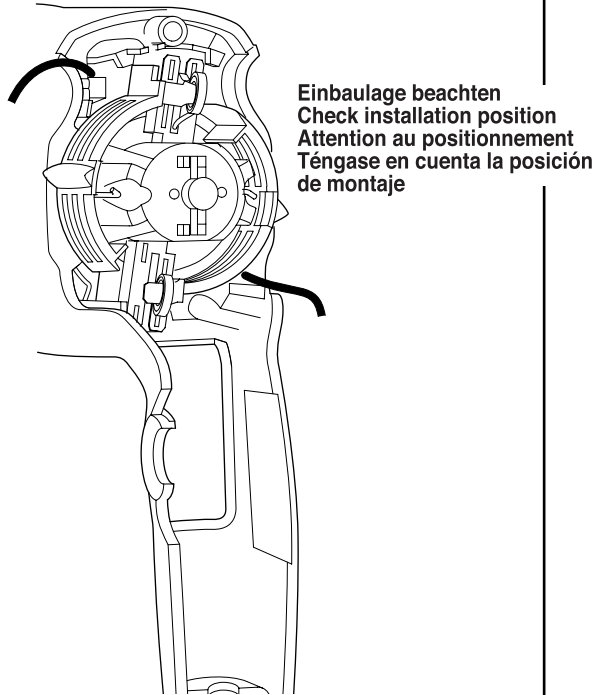

29.5

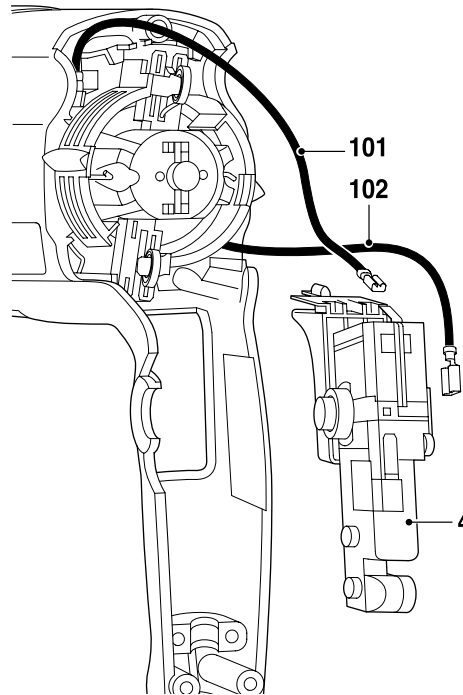

29.6

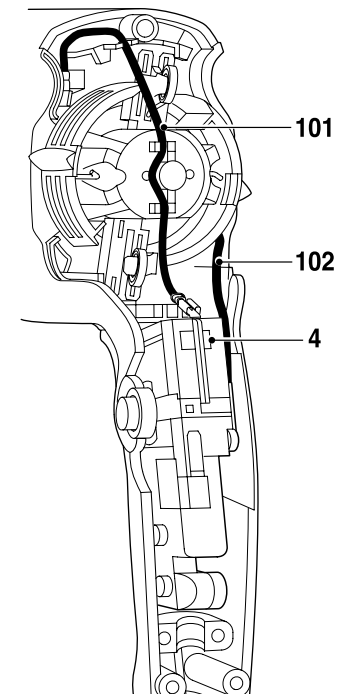

30.6

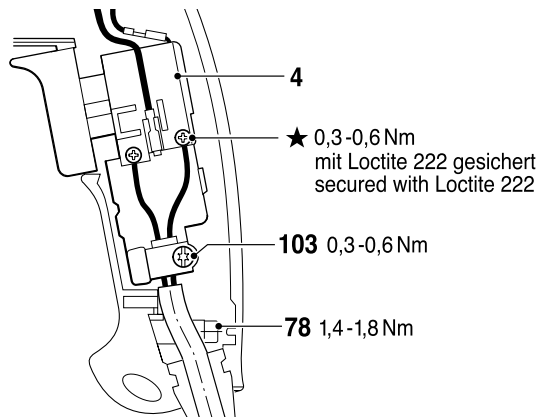

30.7

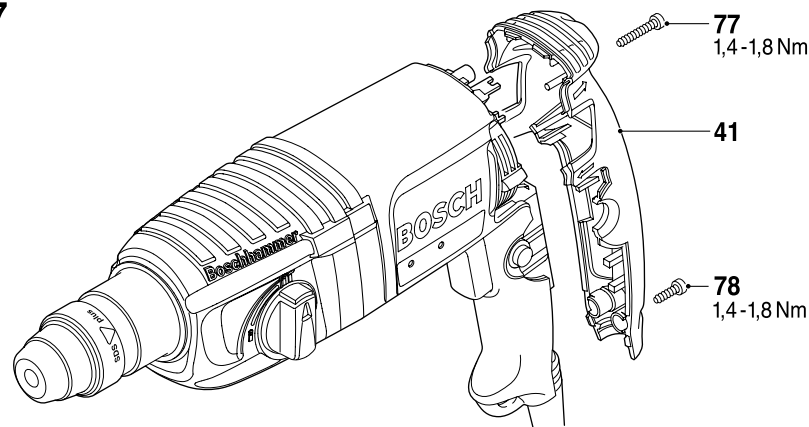

31.

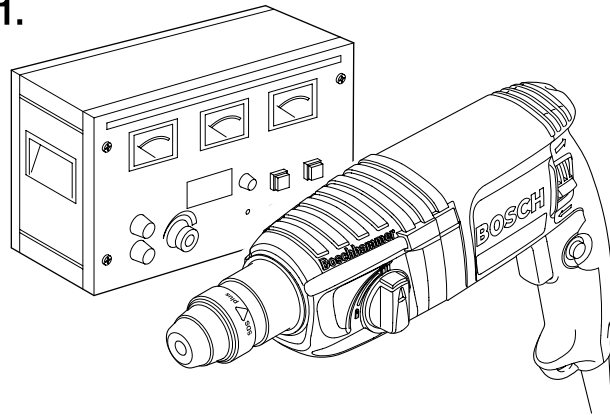

31. Hochspannungsprüfung durchführen.
Beachten:
Die Sicherheitsvorschriften nach DIN, VDE, CEE, AFNOR und weitere in den einzelnen Ländern gültigen Vorschriften sind einzuhalten.
31. Carry out power supply check.
Attention:
Safety regulations according to DIN, VDE, CEE, AFNOR and further regulations applicable in individual countries must be observed.

31. Effectuer un contrôle à haute tension.
Attention:
Respecter les instructions de sécurité selon DIN, VDE, CEE, AFNOR et les autres instructions valables dans les pays respectifs.
31. Efectuar la prueba de alta tensión.
Atención:
Atenerse a las prescripciones de seguridad según DIN, VDE, CEE, AFNOR y a las prescripciones adicionales específicas que pudieran existir en los respectivos países.

32.

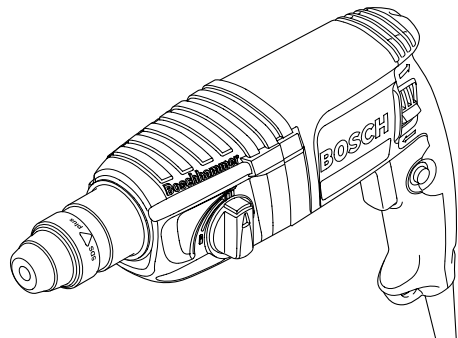

32. Probelauf, Schlagtest, elektrische und mechanische Prüfung durchführen.
32. Perform test run, impact test, electrical and mechanical check-up.

32. Marche à titre d'essai, contrôle de frappe et depercage, effectuer un contrôle mécanique et électrique.
32. Realizar un control funcional, una prueba de taladrado con y sin percusión y los ensayos eléctricos y mecánicos correspondientes.

(Getriebegeh.) Nadelhülse Pos. 67 einpressen

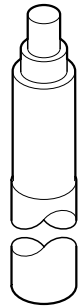
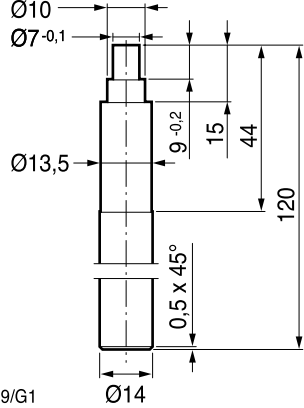

Maße in mm
Dimensions in mm
Cotes en mm
Medidas en mm

EW 576/0139/G1

(Motorgeh.) Polschuh Pos. 2 incl. Pos. 17 einpressen

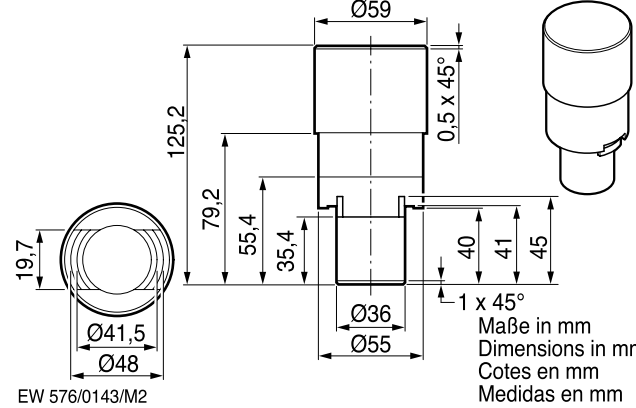

Maße in mm
Dimensions in mm
Cotes en mm
Medidas en mm

EW 576/0143/M2

(Hammerrohrgruppe) Sprengring Pos. 73 montieren

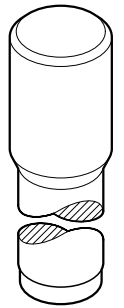
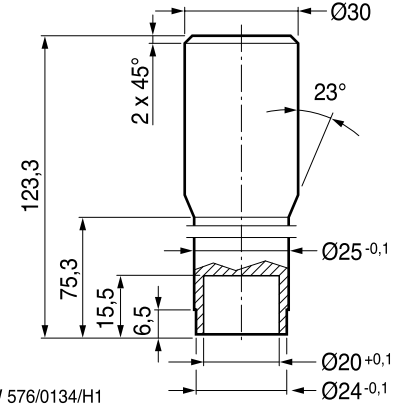

Maße in mm
Dimensions in mm
Cotes en mm
Medidas en mm

EW 576/0134/H1

(Getriebegeh.) Wellendichtring Pos. 66 einpressen

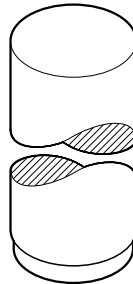
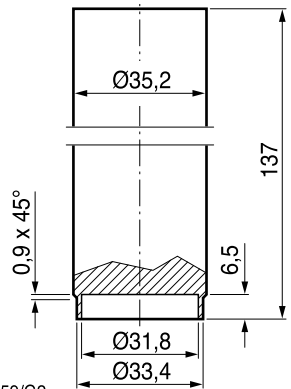

Maße in mm
Dimensions in mm
Cotes en mm
Medidas en mm

EW 576/0159/G2

(Motorgeh.) Einpressen der Schlatkontakte Pos. 19

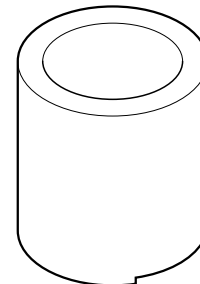
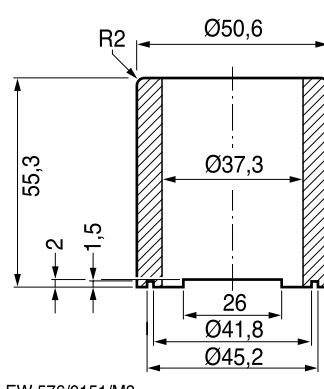

Maße in mm
Dimensions in mm
Cotes en mm
Medidas en mm

EW 576/0151/M3

(Hammerrohrgruppe) Sprengring 72 und Sicherungsring 35 mon.

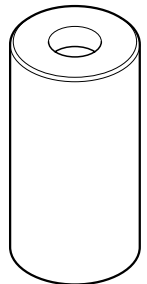
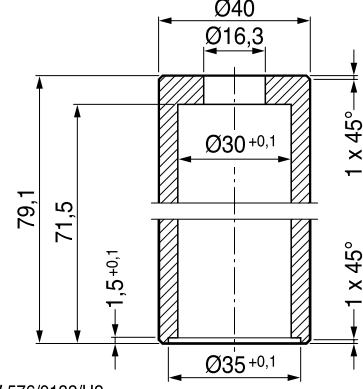

Maße in mm
Dimensions in mm
Cotes en mm
Medidas en mm

EW 576/0132/H2

(Getriebegeh.) Nadellager Pos. 64 einpressen

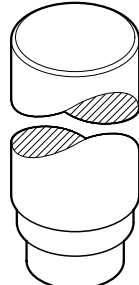
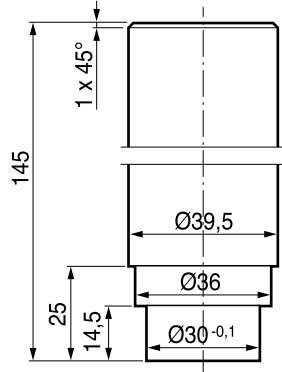

Maße in mm
Dimensions in mm
Cotes en mm
Medidas en mm

EW 576/0160/G3

Vorderes Ankerlager Pos. 14 Aufpressen

A Hilfswerkzeug zum Selbstanfertigen
Auxiliary tool (for your own manufacture)
Outil auxiliaire (fabrication locale)
Utile (fabricación particular)

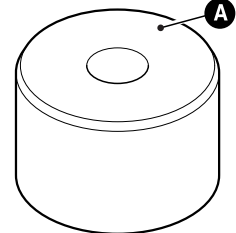
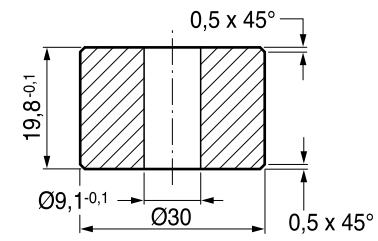

Maße in mm
Dimensions in mm
Cotes en mm
Medidas en mm

EW 576/0133/A4

Stirrad Pos. 23 aufpressen

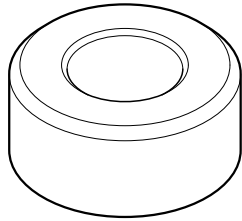
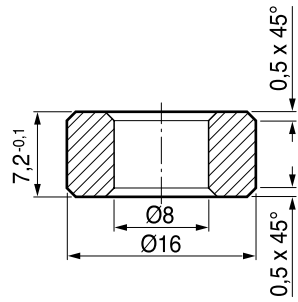

Maße in mm
Dimensions in mm
Cotes en mm
Medidas en mm

EW 576/0155/Z1

Sprengung Pos. 87 montieren

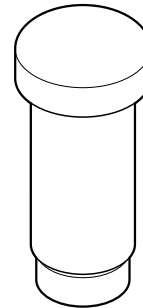
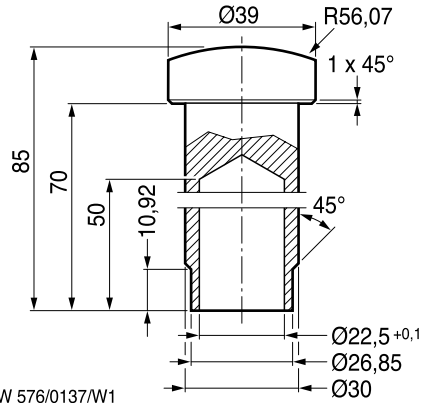

Maße in mm
Dimensions in mm
Cotes en mm
Medidas en mm

EW 576/0137/W1

Sprengung Pos. 74 montieren

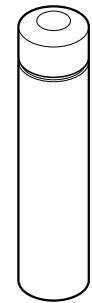
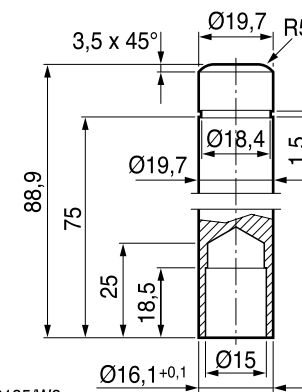

Maße in mm
Dimensions in mm
Cotes en mm
Medidas en mm

EW 576/0135/W2

Abstreifer Pos. 59 montieren

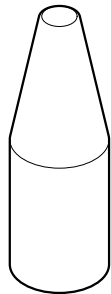
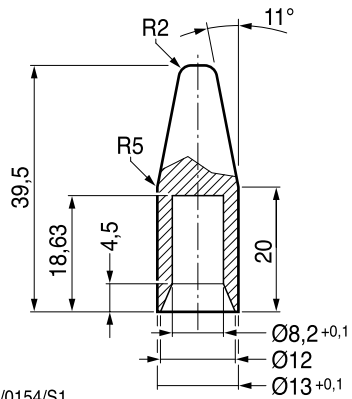

Maße in mm
Dimensions in mm
Cotes en mm
Medidas en mm

EW 576/0154/S1

Sprengung Pos. 87 montieren

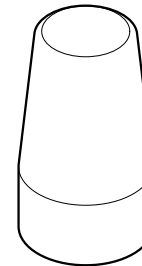
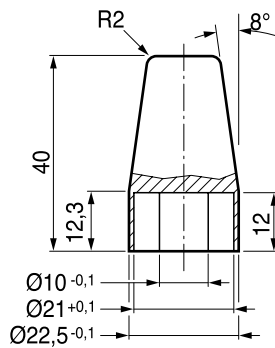

Maße in mm
Dimensions in mm
Cotes en mm
Medidas en mm

EW 576/0138/W1

Sprengung Pos. 74 montieren

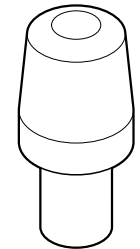
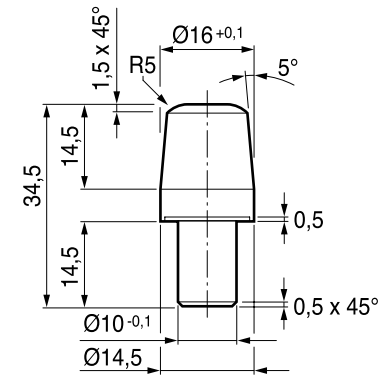

Maße in mm
Dimensions in mm
Cotes en mm
Medidas en mm

EW 576/0136/W2

Teile fetten (35 g); Rest in Getrieberaum Pos. 840.
 Grease the parts (35 g); rest into gear compartment pos. 840.
 Graisser les pieces (35 g); la graisse restante dans le compartiment d'engrenage 840.
 Engrasar las piezas (35 g); resto en el compartimento del engranaje pos. 840.

Fett-Gesamtmenge 40g

Zahnräder-Zähne fetten mit 1 615 430 001
 Grease all gear teeth
 Les dents graisser
 Dientes engrasar

