

BOSCH



Service



INSTANDSETZUNGSHINWEISE
REPAIR INSTRUCTIONS
INSTRUCTIONS DE REPARATION
INSTRUCCIONES DE REPARACION

EW/WJW 0 611 213 0../1../7.. (99 - 07) X

Bohrhammer
Rotary Hammer
Marteau perforateur
Martillo perforador

Typ 0 611 213 0 .. = GBH 24 V
0 611 213 1 .. = GBH 24 VR
0 611 213 7 .. = GBH 24 VRE

Änderungen vorbehalten. Unsere Erzeugnisse werden stets dem neuesten technischen Stand angepaßt. Deshalb behalten wir uns Änderungen vor.

Modifications. Our products are constantly modified to meet new technical standards. We therefore reserve the right to alter data and specifications without prior notice.

Modifications. Nos produits sont continuellement adaptés aux dernières nouveautés techniques et les dates sont données sous réserve de changement.

Modificaciones. Nuestros fabricados van siendo adaptos constantemente a las últimas conquistas técnicas. Por ello, tenemos que reservarnos el derecho de introducir modificaciones en los datos técnicos.

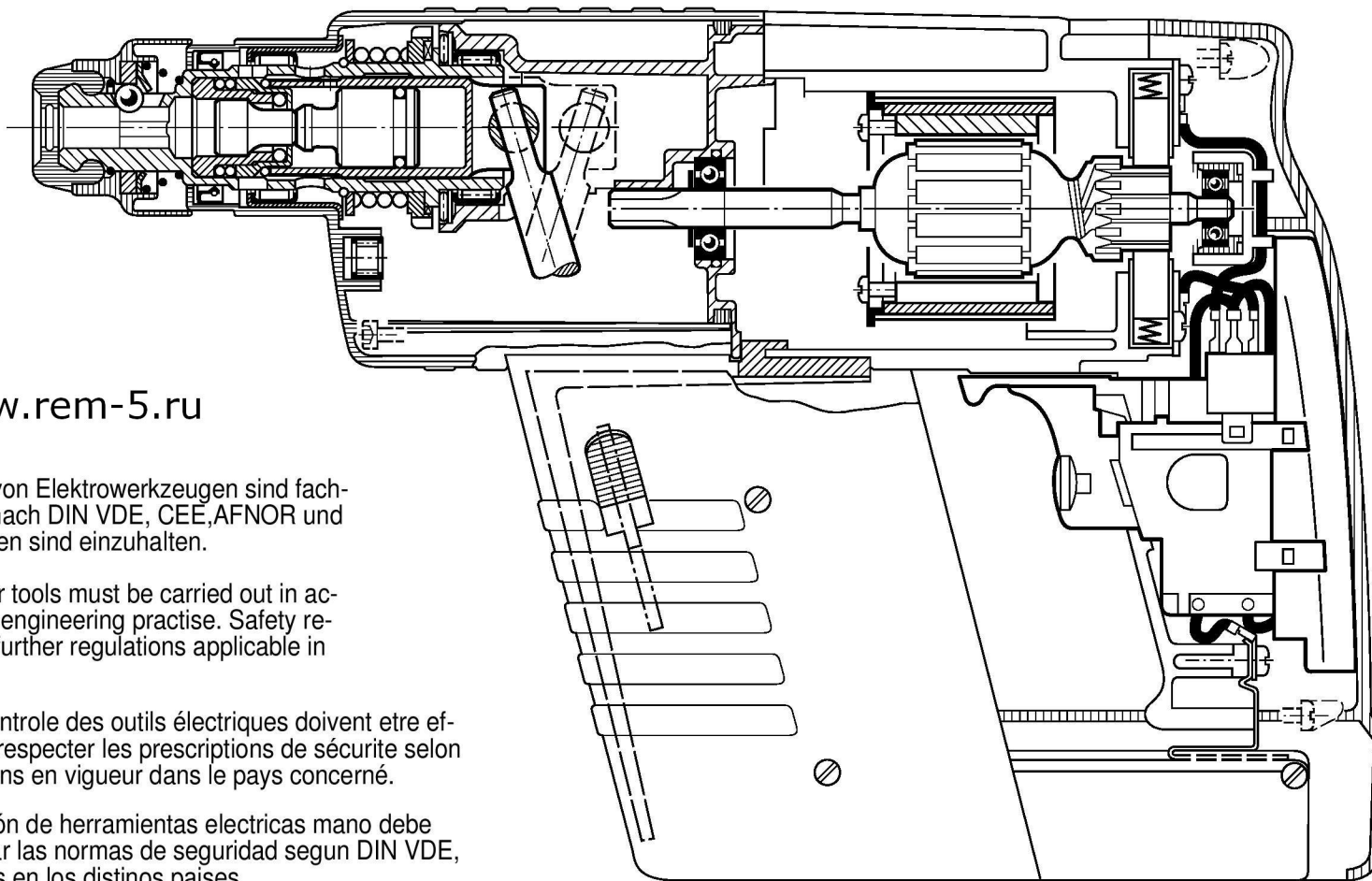

Опубликовано на сайте www.rem-5.ru

Beachten: Instandsetzung, Änderung und Prüfung von Elektrowerkzeugen sind fachgerecht durchzuführen. Die Sicherheitsvorschriften nach DIN VDE, CEE, AFNOR und weitere in den einzelnen Ländern gültigen Vorschriften sind einzuhalten.

Attention: Repair, modification, and testing of power tools must be carried out in accordance with the generally recognised principles of engineering practise. Safety regulations according to DIN VDE, CEE, AFNOR and further regulations applicable in individual countries must be observed.

Attention: La remise en état, la modification et le contrôle des outils électriques doivent être effectués par des personnes qualifiées. Il convient de respecter les prescriptions de sécurité selon DIN VDE, CEE, AFNOR, ainsi que les réglementations en vigueur dans le pays concerné.

Obsérvese: La reparación, modificación y verificación de herramientas eléctricas mano debe efectuarse en forma técnicamente correcta. Respetar las normas de seguridad según DIN VDE, CEE, AFNOR, así como otras disposiciones vigentes en los distintos países.

ROBERT BOSCH GMBH GESCHÄFTSBEREICH ELEKTROWERKZEUGE D-70745 LEINFELDEN-ECHTERDINGEN



Typ 0 611 213 0../1../7..

Zerlegen

Für die Demontage werden handelsübliche Werkzeuge benötigt.

1. Zerlegen nach Explosions-, Schnittzeichnung und diesem Instandsetzungshinweis.

Disassembly

Use normal trade tools by disassembly.

1. Disassembly using explosion, cut-away drawings and these repair instructions!

Démontage

Pour le démontage, des outils en usage dans le commerce sont nécessaires.

1. Démontez l'appareil suivant la vue éclatée, le plan en coupe et ces instructions de réparation.

Desmontaje

Para el desmontaje no se precisan herramientas especiales.

1. Realizar el desmontaje conforme a los dibujos en perspectiva y en sección, y a estas instrucciones de reparación.

1.

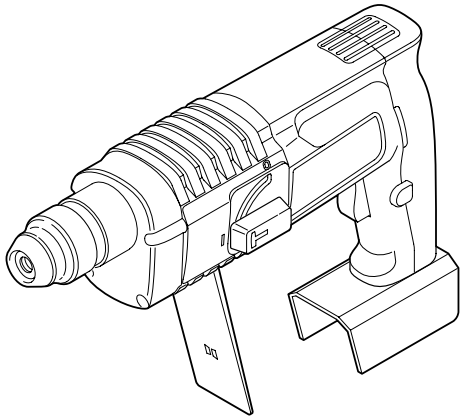

2.

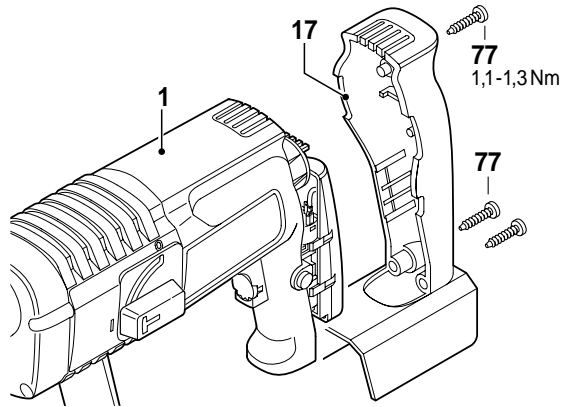

2.1

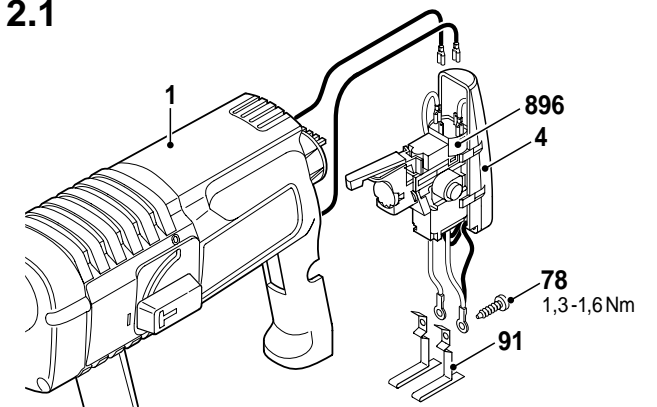

2.2

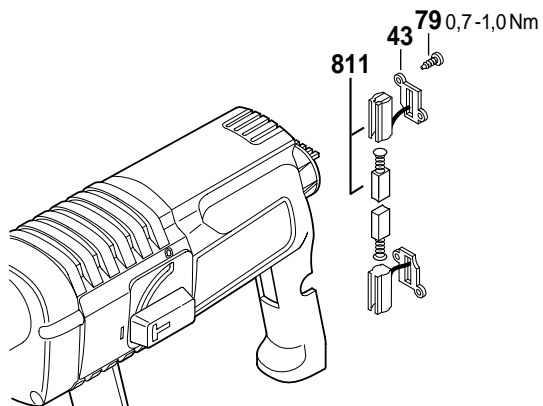

3.

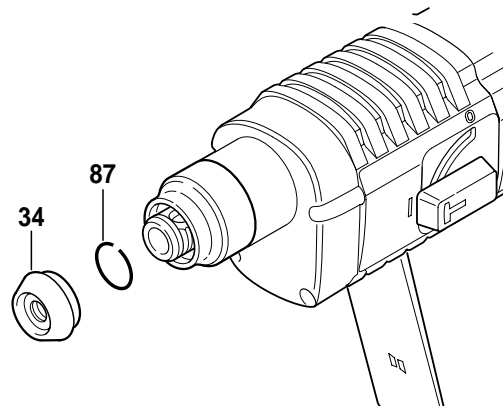

3.1

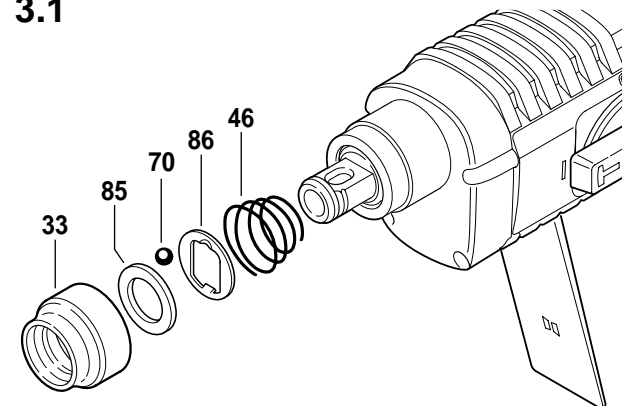

4.

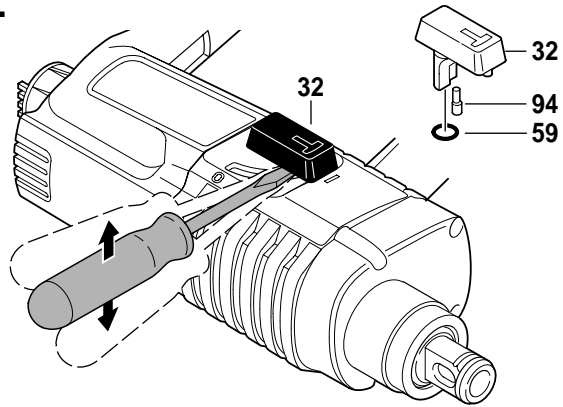

5.

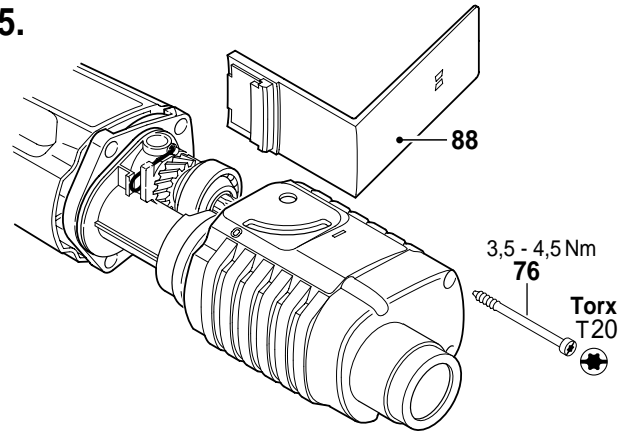

6.

Abziehvorrichtung
Extracting device
Dispositif extracteur
Dispositivo extractor

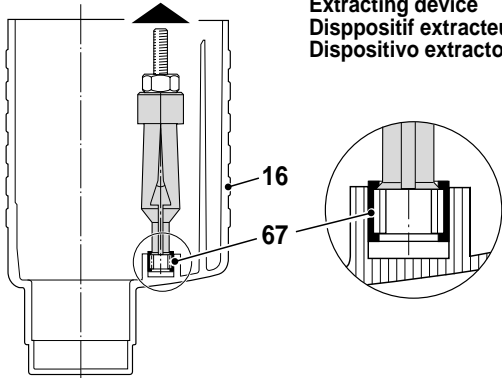

6.1

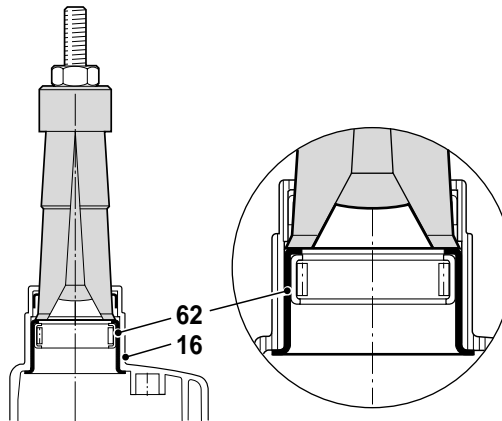

6.2

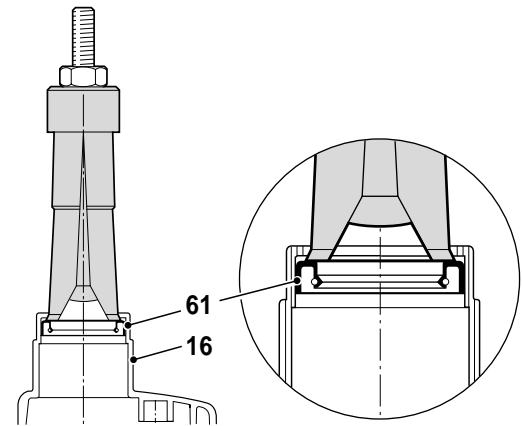

7.

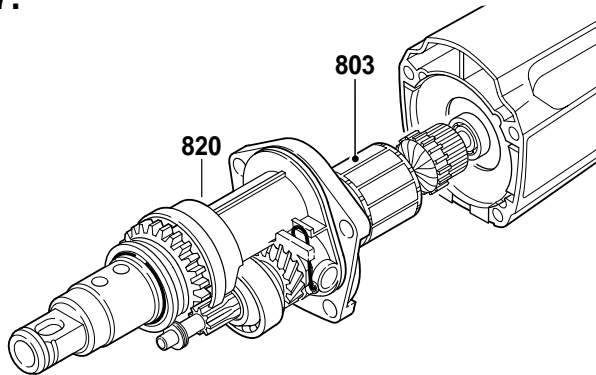

8.

Schutzbacken **S**
Vise jaws
Mâchoires de l'étau
Mordazas de tornillo
de banco

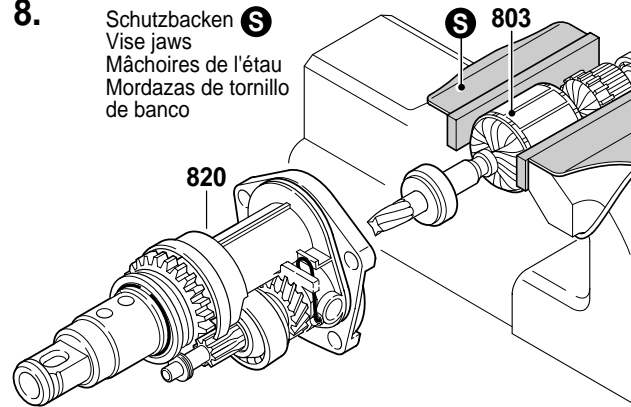

8.1

Austrastmoment 12- 20 Nm
Slipping point of clutch
Couple de glessement
Momento de desen-
clavamiento

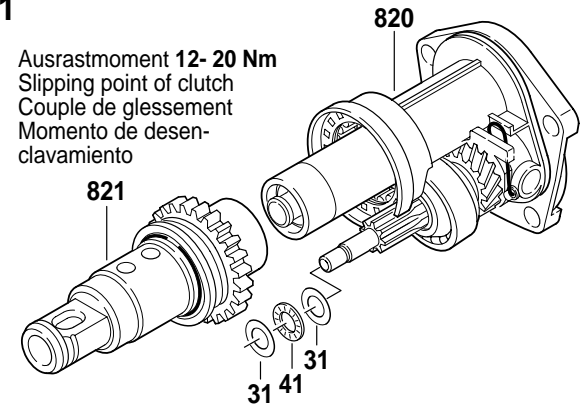

9. **A** KDEW 8103 nach Skizze ändern
 modify according to drawing
 modifier selon le schéma
 modificar según croquis

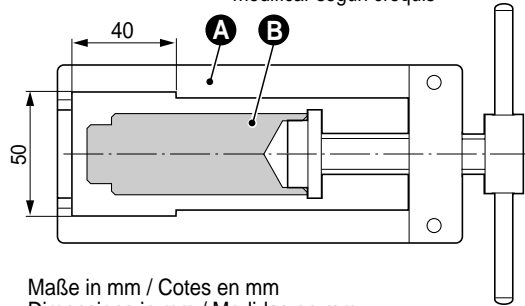

Maße in mm / Cotes en mm
 Dimensions in mm / Medidas en mm

9.1 Hilfswerkzeug zum Selbstanfertigen
 Auxiliary tool (for your own manufacture)
 Outil auxiliaire (fabrication locale)
 Utile (fabricación particular)

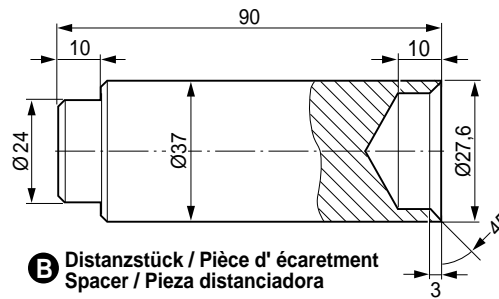

B Distanzstück / Pièce d'écartement
 Spacer / Pieza distanciadora

9.2 **A** KDEW 8103

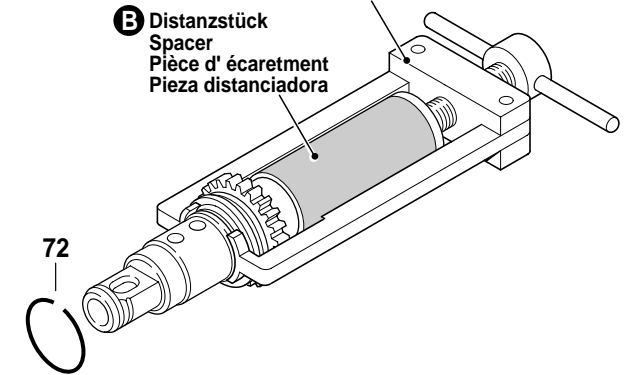

9.3

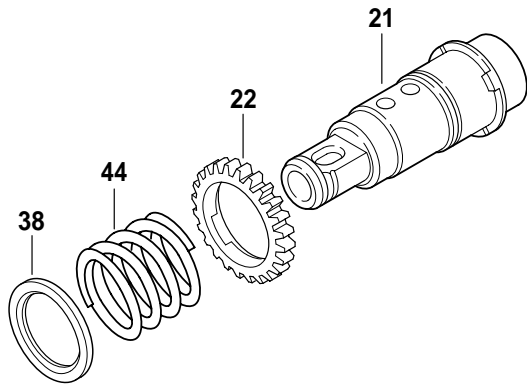

9.4

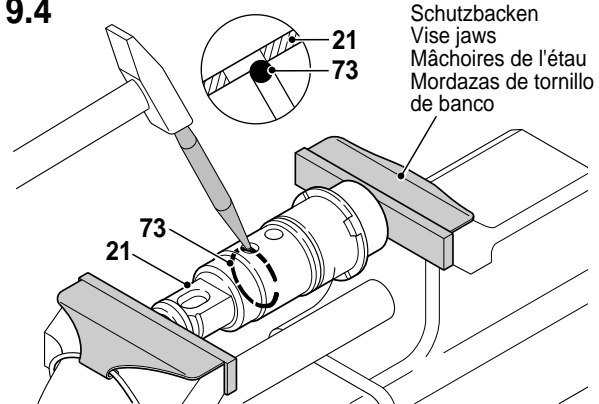

9.5

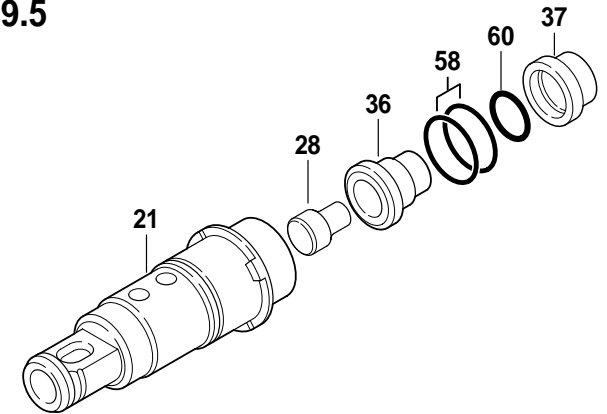

10.

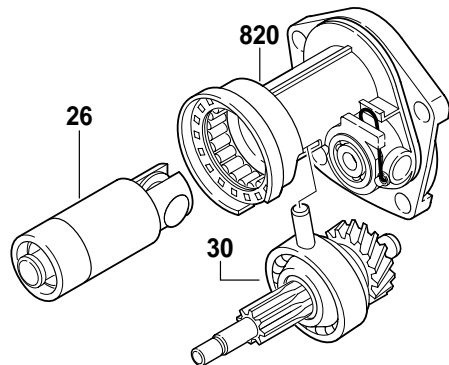

10.1

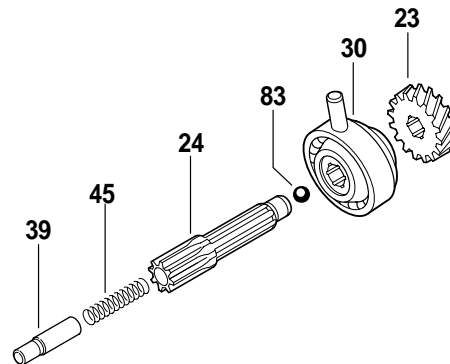

10.2

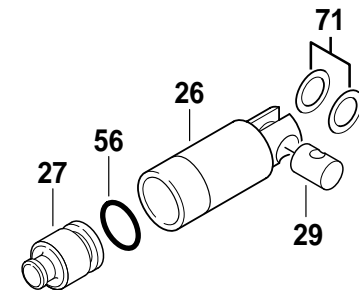

11.

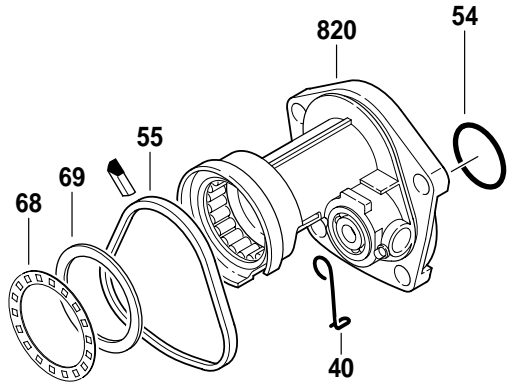

11.1

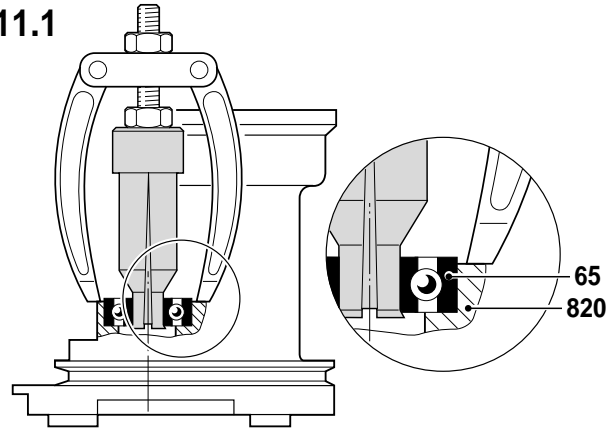

11.2

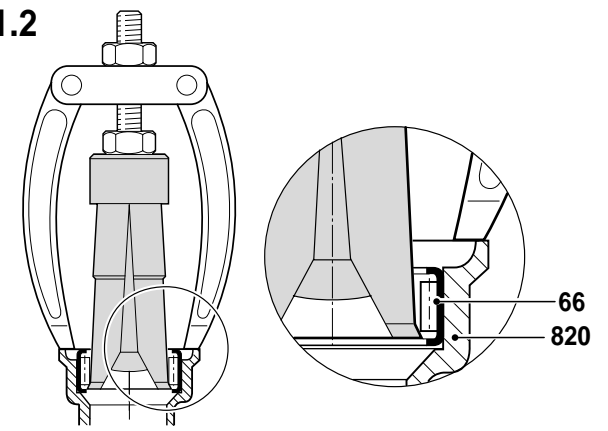

12.

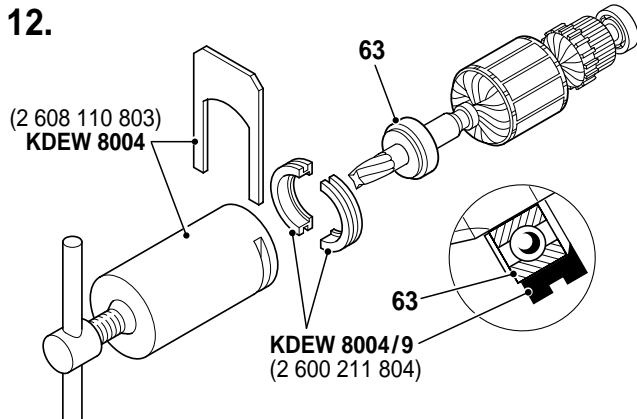

12.1

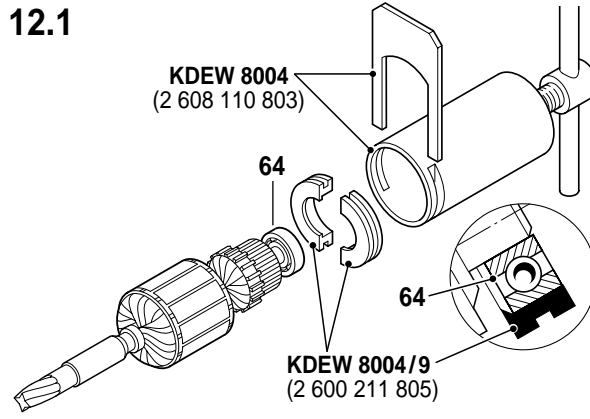

13.

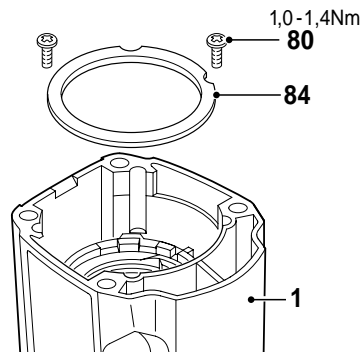

13.1

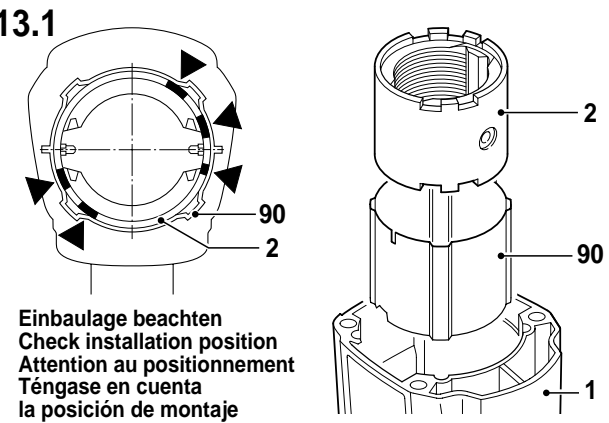

14.

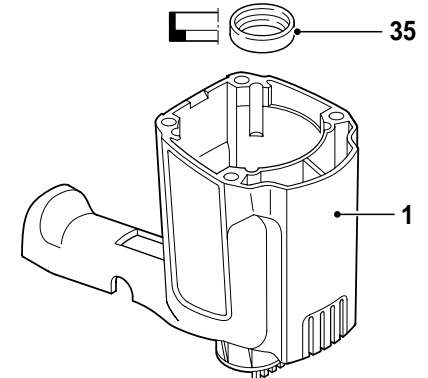

Zusammenbau

Montage nach Explosionszeichnung und diesem Instandsetzungshinweis.

Alle Teile sind gereinigt, abgenutzte und beschädigte Teile werden ersetzt.

Nur Original-Ersatzteile verwenden.

Zähne aller Zahnräder mit Fett **1 615 430 002** bestreichen.

Bitte Schmierhinweise beachten!

Assembly

Assembly using explosion drawings and these repair instructions!

Clean all parts, replace worn-out and damaged parts.

Use only original spare parts!

Grease all gear teeth **1 615 430 002**.

Please note lubrication instructions!

Montage

Le montage s'effectue selon la vue éclatée et les instructions de réparation suivantes.

Toutes les pièces sont nettoyées, les pièces usées ou endommagées doivent être remplacées par des nouvelles. Pour le remplacement de pièces, n'utiliser que des pièces d'origine.

Les dents graisser **1 615 430 002**.

Respecter les instructions de graissage!

Montaje

Realizar el montaje conforme a los dibujos en perspectiva y a estas instrucciones de reparación.

Todas las piezas deben estar limpias. Las piezas desgastadas o dañadas deben reemplazarse por piezas nuevas. Utilizar solamente piezas de repuesto originales.

Dientes engrasar **1 615 430 002**.

Observar las instrucciones de lubricación!

21.

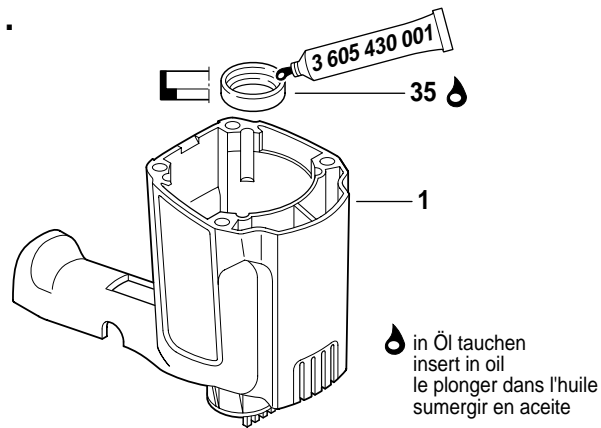

21.1

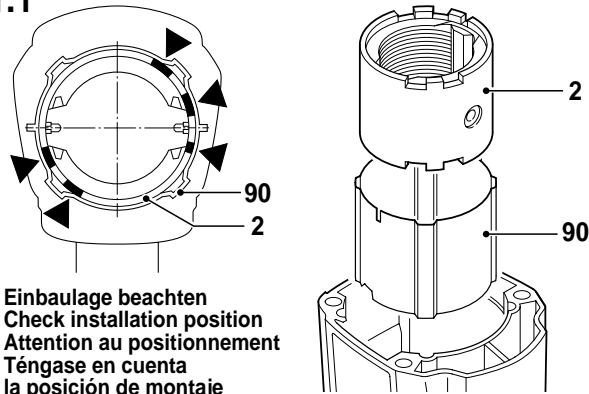

Einbauage beachten
Check installation position
Attention au positionnement
Téngase en cuenta
la posición de montaje

21.2

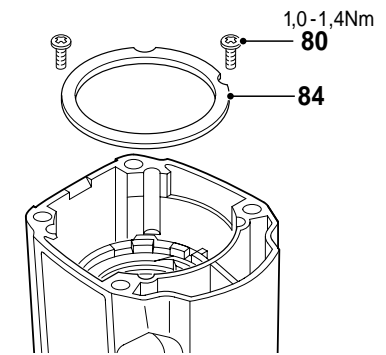

22.

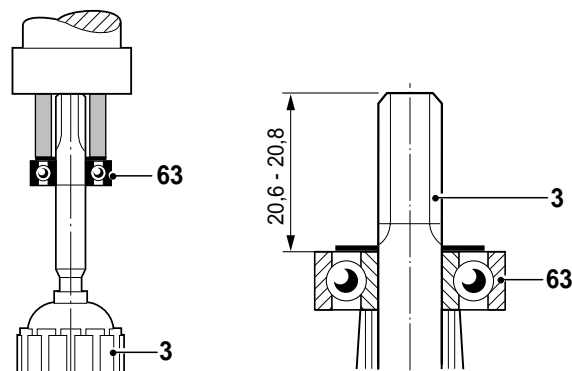

22.1

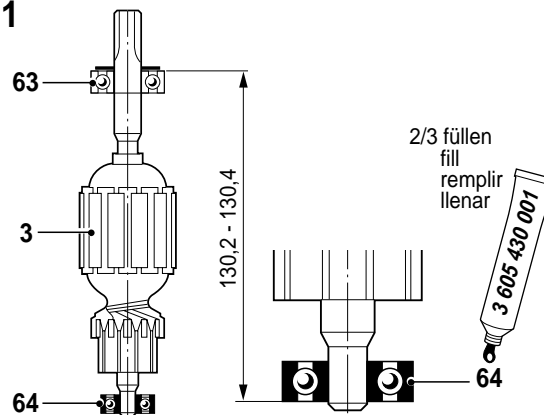

23.

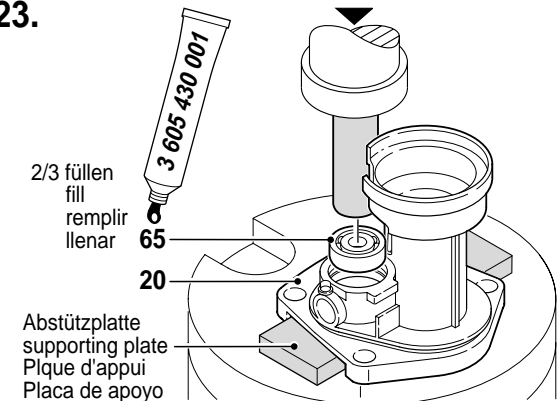

23.1

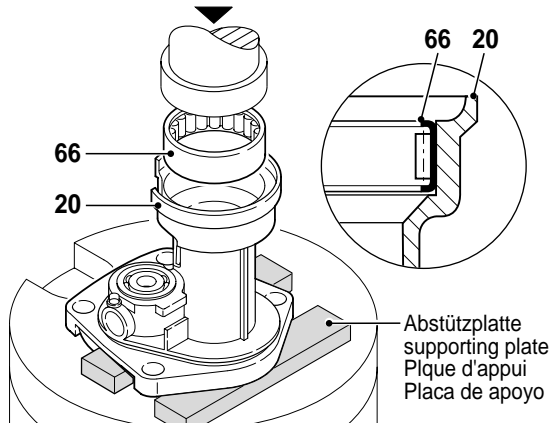

23.2

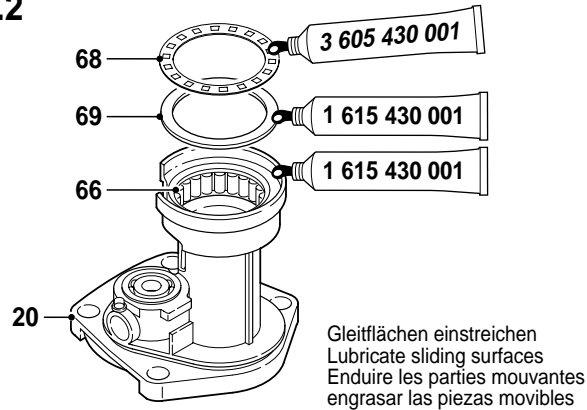

23.3

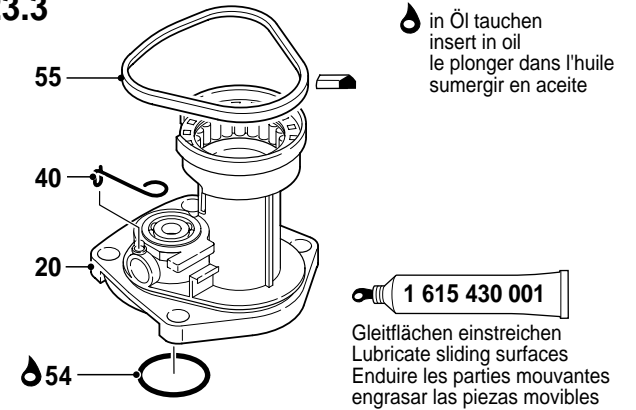

23.4

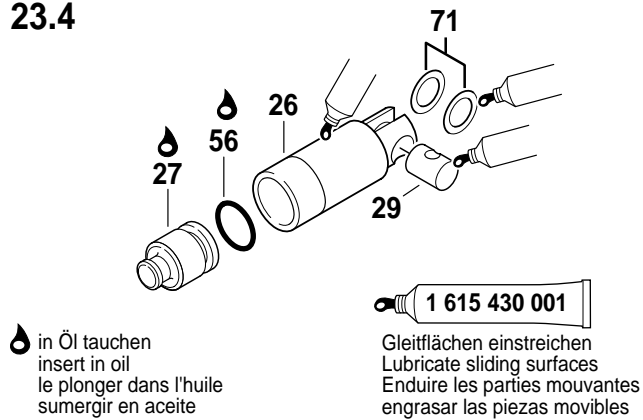

23.5

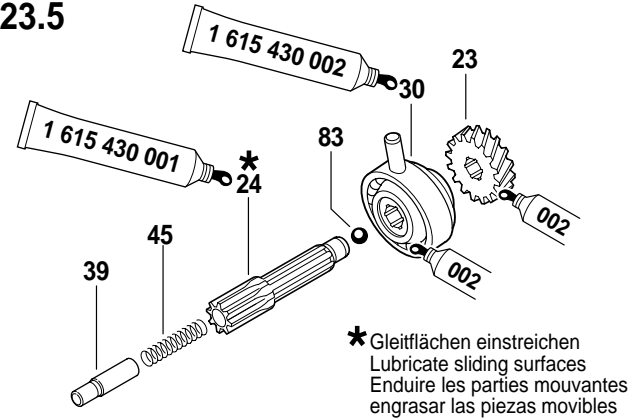

23.6

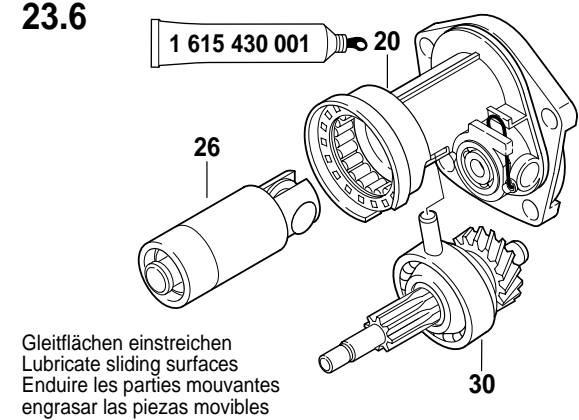

24.

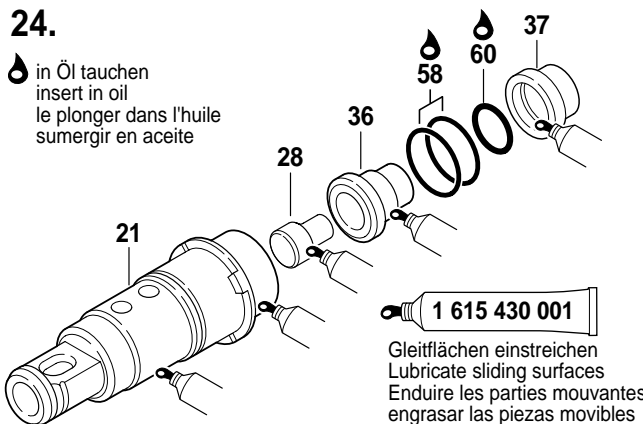

24.1

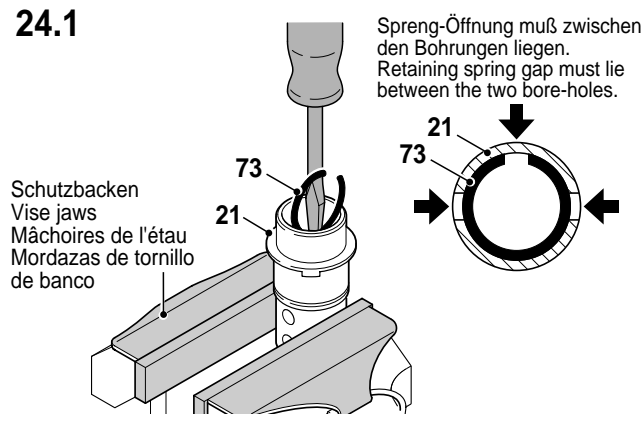

24.2

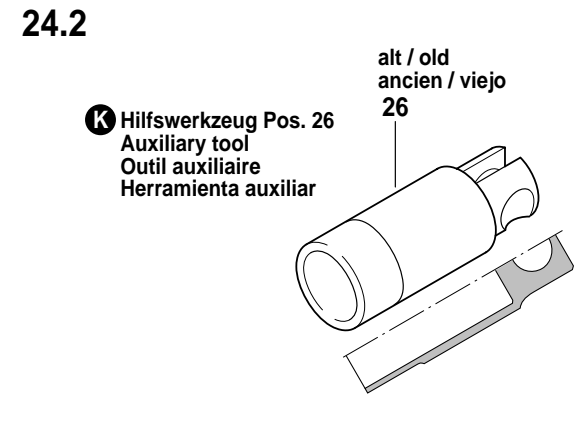

24.3

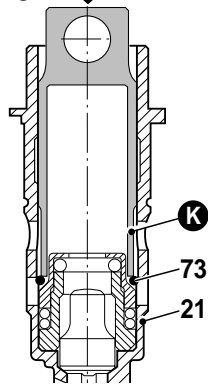

Spreng-Öffnung muß zwischen den Bohrungen liegen.
Retaining spring gap must lie between the two bore-holes.

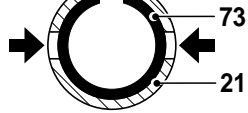

K

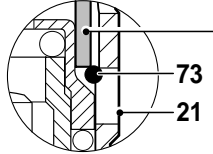

Pos. 26
Hilfswerkzeug
Auxiliary tool
Outil auxiliaire
Herramienta auxiliar

24.4

Einbaulage beachten
Check installation position
Attention au positionnement
Téngase en cuenta la posición de montaje

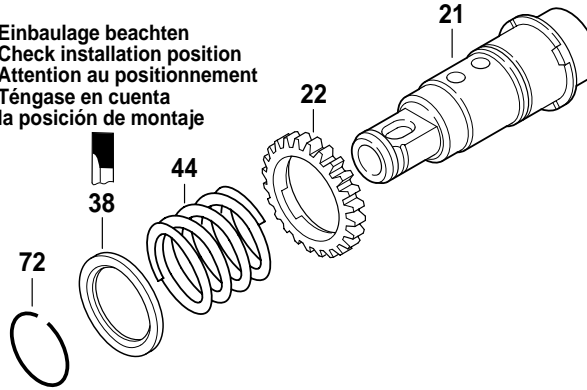

25.

H Hilfswerkzeug zum Selbstanfertigen
Auxiliary tool (for your own manufacture)
Outil auxiliaire (fabrication locale)
Utile (fabricación particular)

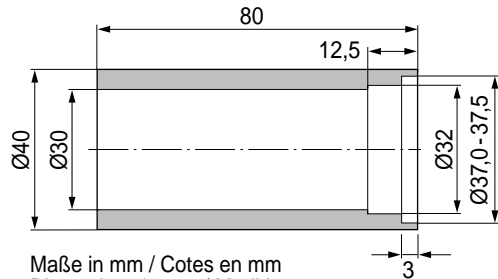

Maße in mm / Cotes en mm
Dimensions in mm / Medidas en mm

25.1

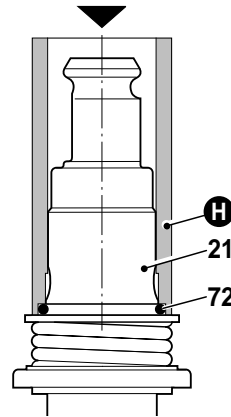

H Hilfswerkzeug
Auxiliary tool
Outil auxiliaire
Herramienta auxiliar

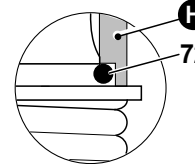

25.2

Austrastmoment 12- 20 Nm
Slipping point of clutch
Couple de glissement
Momento de desenclavamiento

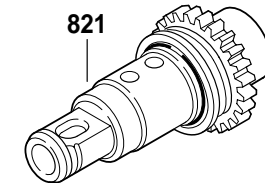

25.3

Zähne füllen
Fill teeth
Remplir les dents
Llenar dientes

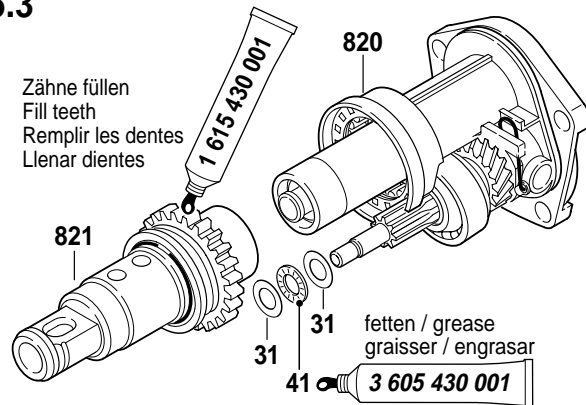

fetten / grease
graisser / engrasar

25.4

S Schutzbacken
Vise jaws
Mâchoires de l'étau
Mordazas de tornillo de banco

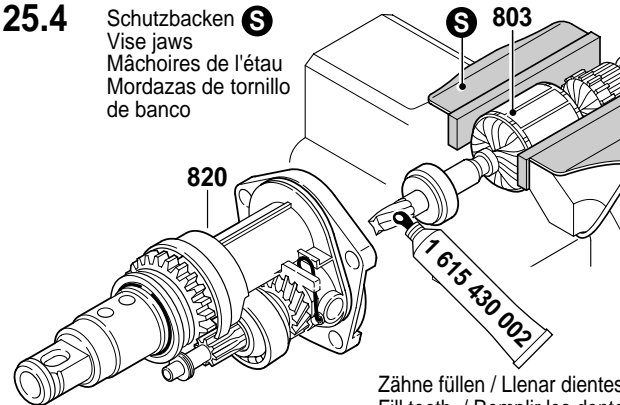

Zähne füllen / Llenar dientes
Fill teeth / Remplir les dents

25.5

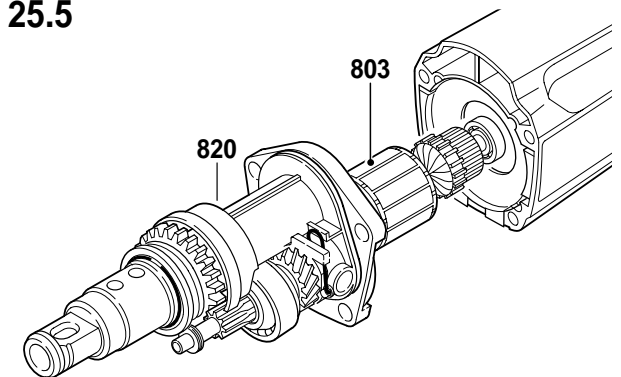

26.

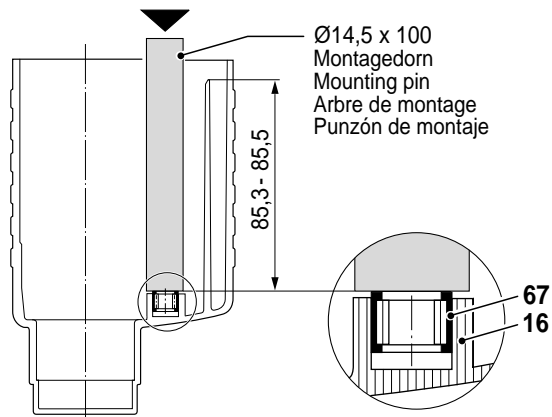

Ø14,5 x 100
Montagedorn
Mounting pin
Arbre de montage
Punzón de montaje

26.1

⊙ Hilfswerkzeug zum Selbstanfertigen
Auxiliary tool (for your own manufacture)
Outil auxiliaire (fabrication locale)
Utile (fabricación particular)

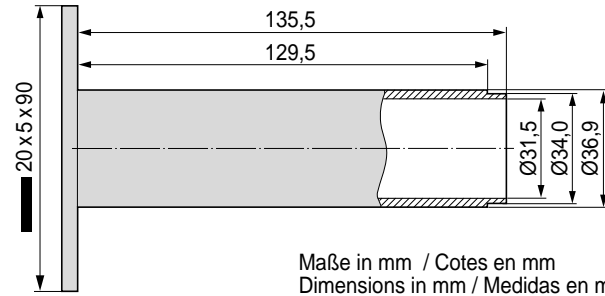

Maße in mm / Cotes en mm
Dimensions in mm / Medidas en mm

26.2

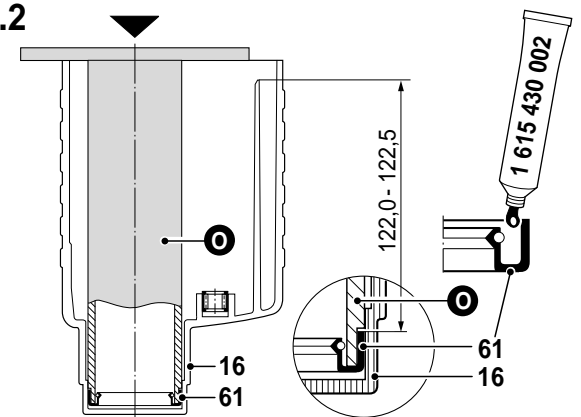

26.3

Ⓟ Hilfswerkzeug zum Selbstanfertigen
Auxiliary tool (for your own manufacture)
Outil auxiliaire (fabrication locale)
Utile (fabricación particular)

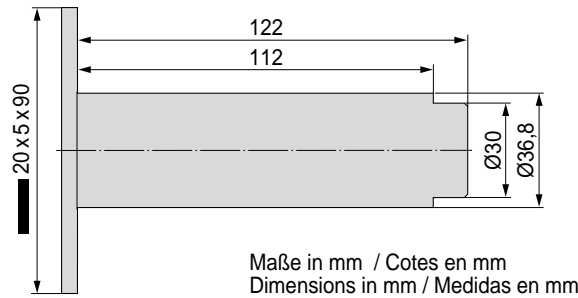

Maße in mm / Cotes en mm
Dimensions in mm / Medidas en mm

26.4

Neue Ausführung
New execution
Nouvelle exécution
Nueva ejecución

Alte Ausführung
Old execution
Ancien exécution
Vieja ejecución

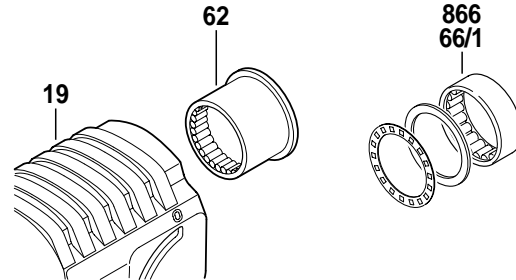

26.5

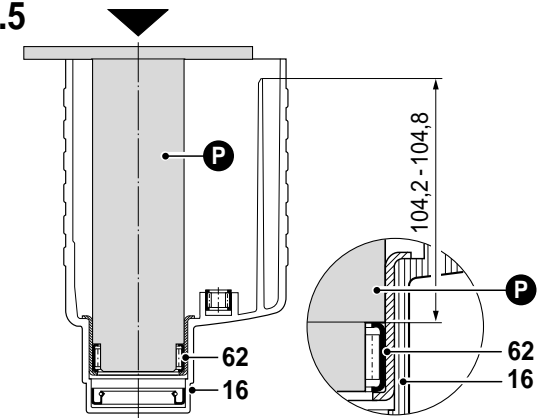

26.6

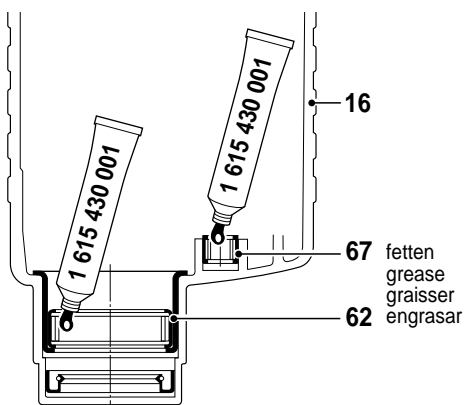

fetten
grease
graisser
engrasar

26.7

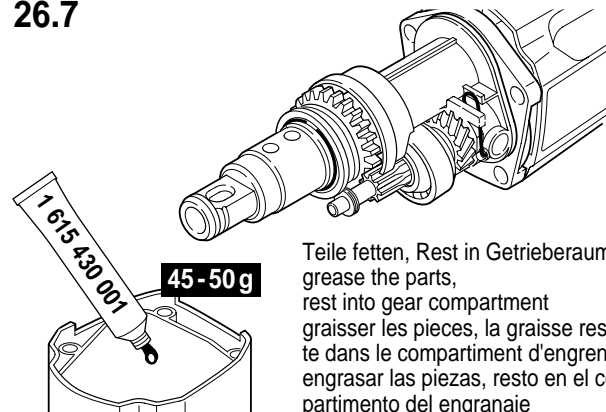

45-50 g

Teile fetten, Rest in Getrieberaum
grease the parts, rest into gear compartment
graisser les pieces, la graisse restant
dans le compartiment d'engrenage
engrasar las piezas, resto en el compartimento del engranaje

26.8

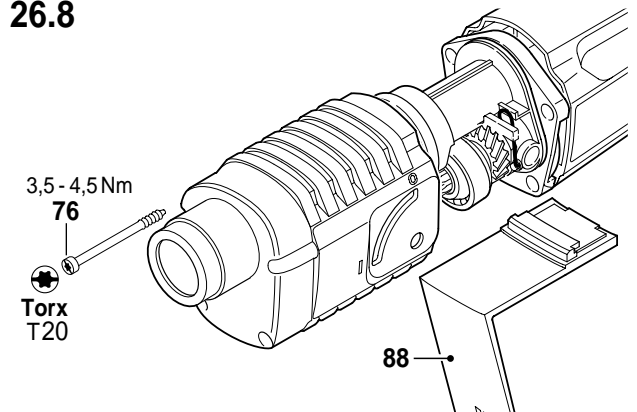

3,5-4,5Nm
76
Torx
T20

27.

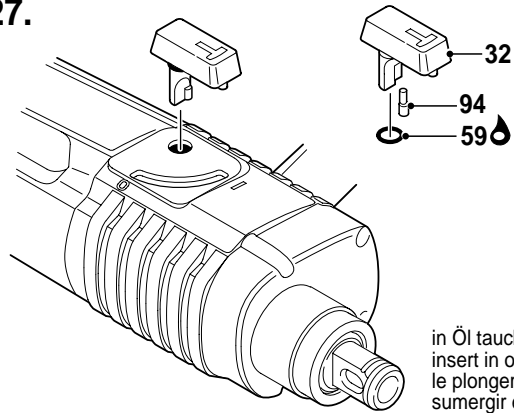

in Öl tauchen
insert in oil
le plonger dans l'huile
sumergir en aceite

28.

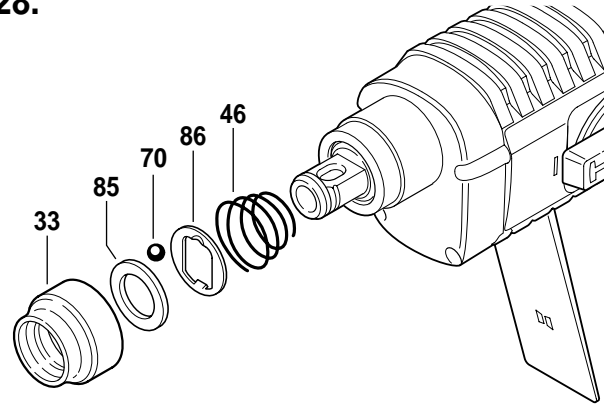

28.1

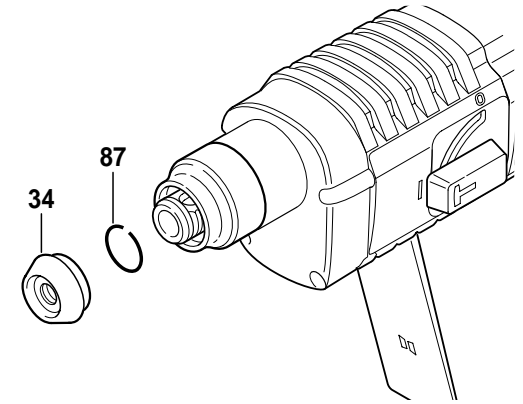

29.

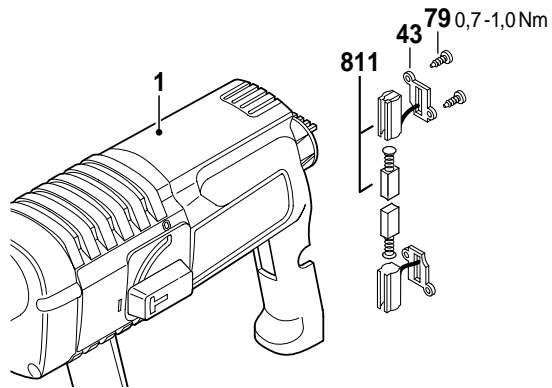

29.1

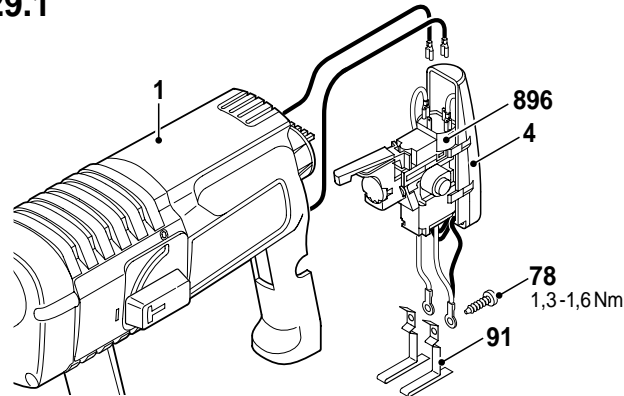

29.2

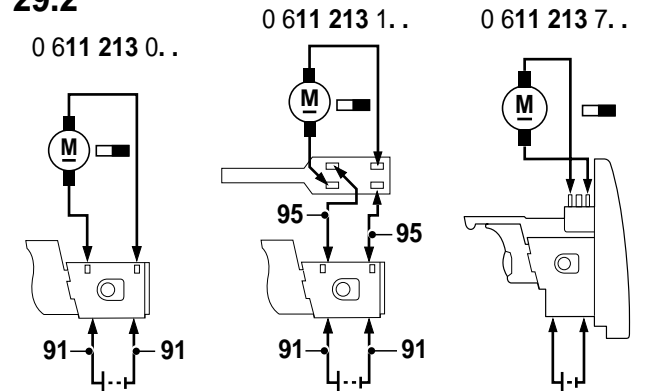

30.

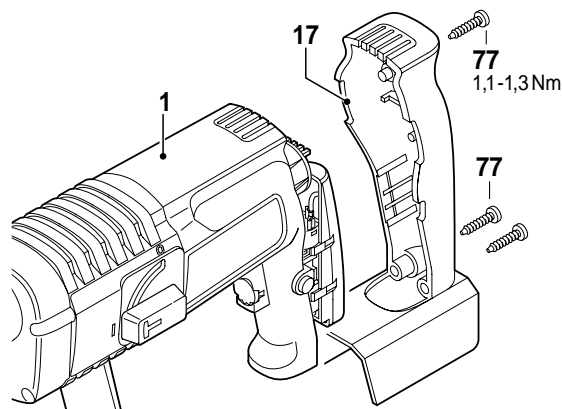

31.

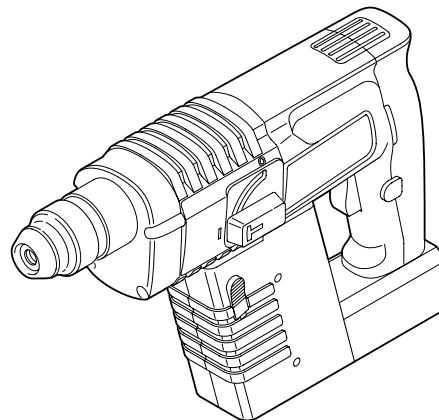

31. Probelauf, Schlagtest, elektrische und mechanische Prüfung durchführen.

31. Perform test run, impact test, electrical and mechanical check-up.

31. Marche à titre d'essai, contrôle de frappe et deperçage, effectuer un contrôle mécanique et électrique.

31. Realizar un control funcional, una prueba de taladrado con y sin percusión y los ensayos eléctricos y mecánicos correspondientes.

Schmierung 0 611 213 0.. = GBH 24 V
 Lubrication 0 611 213 1.. = GBH 24 VR
 Lubrification 0 611 213 7.. = GBH 24 VRE
 Lubricacion

Stand / Issue: 99-07

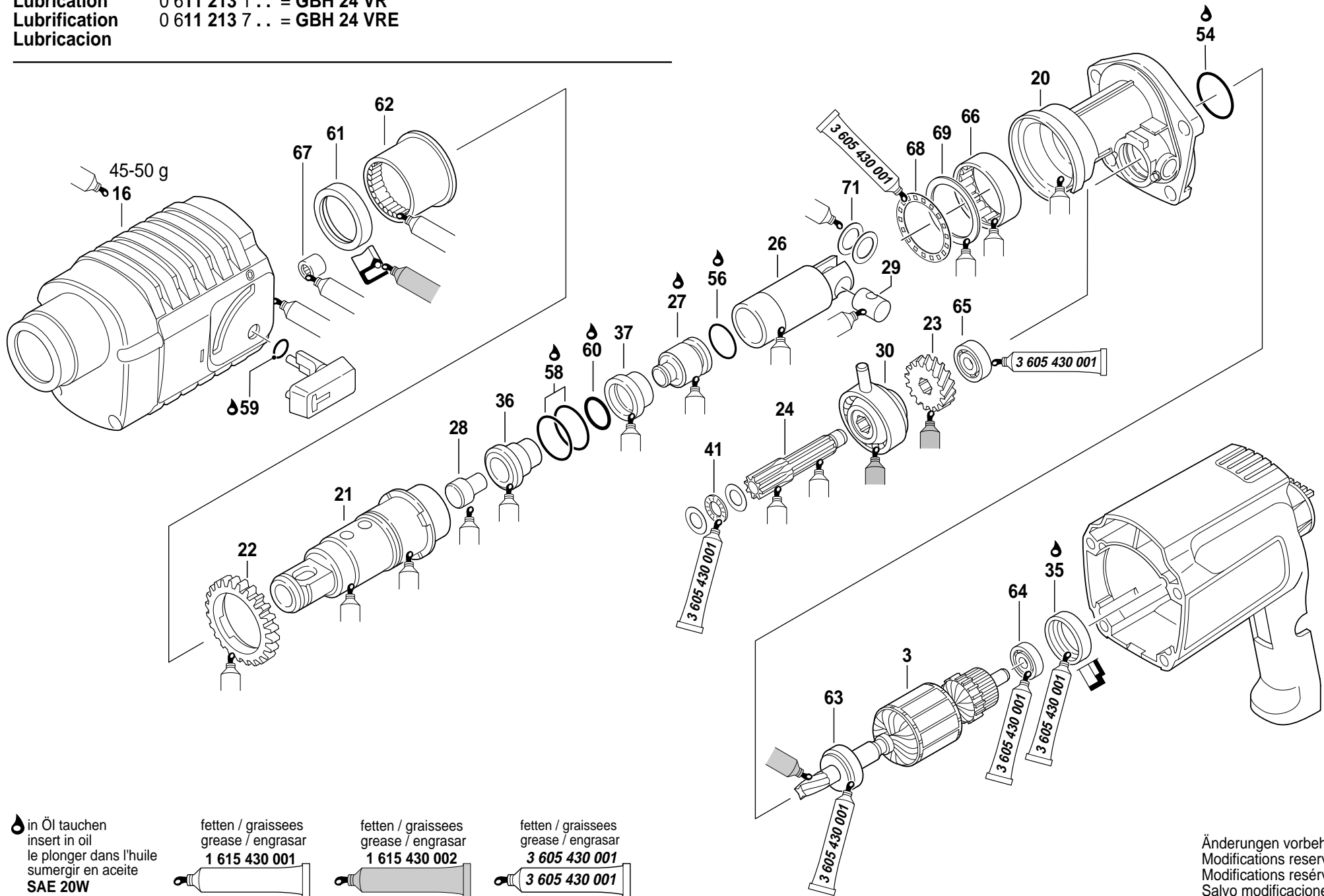

in Öl tauchen
 insert in oil
 le plonger dans l'huile
 sumergir en aceite
SAE 20W

fetten / grassees
 grease / engrasar
1 615 430 001

fetten / grassees
 grease / engrasar
1 615 430 002

fetten / grassees
 grease / engrasar
3 605 430 001

Änderungen vorbehalten
 Modifications reserved
 Modifications réservées
 Salvo modificaciones

Schmierung 0 611 213 0 .. = GBH 24 V
Lubrication 0 611 213 1 .. = GBH 24 VR
Lubrification 0 611 213 7 .. = GBH 24 VRE
Lubricacion

Stand / Issue: 99-07

Änderungen vorbehalten
 Modifications reserved
 Modifications réservées
 Salvo modificaciones

Schmierstelle Lubrication point Point de lubrification Punto de lubricacion	Fig./Pos.	Schmierstoff Fett Öl Lubricant grease oil Lubrifiant graisse huile Lubricante grasa aceite	Mengen Quantity Quantite Cantidad	Schmiervorschrift Lubricating instructions Indications de graissage Instrucciones de lubricacion
Getriebe und Schlagwerkraum Gear and percussion mechanism space Carter de l' engrenage et boîtier du système de frappe Engranaje y parte de engranaje		1 615 430 001	45-50 g	Teile fetten, Rest in Getrieberaum grease the parts, rest into gear compartment graisser les pieces, la graisse restante dans le compartiment d'engrenage engrasar las piezas, resto en el compartimento del engranaje
Gleitende Teile Sliding parts Pieces glissantes Piezas deslizantes	16; 20;21 22;24;26 28;29;36 37;69;71			Gleitflächen einstreichen lubricate sliding surfaces enduire les parties mouvantes engrasar las piezas movibles
Nadelhülse Needle bushing Douille a aiguilles Casquillo de agujas	62 67		*	fetten grease graisser engrasar
Rillenkugellager Deep-groove ball bearing Roulement a billes rigide Rodamiento radial rigido	63 64 65	3 605 430 001	*	2/3 füllen fill remplir llenar
Gummiring/ Rollenkranz Rubber ring / Roller cage Bague en caoutchouc Anillo de goma	35			fetten grease graisser engrasar
Rollenkranz Roller-cage assembly Couronne de rouleaux Corona de rodillos	41 68			fetten grease graisser engrasar
Antriebslager Drive end shield Flasque cote entrainement Tapa lado accionamiento	30	1 615 430 002		Teile fetten grease the parts graisser les pieces engrasar las piezas
Wellendichtring Shaft sealing ring Joint a levres Reten para arboles	61			Hohlraum zwischen Dichtlippen füllen fill cavity between sealing lips remplir cavite entre les levres du joint llenar el vacio entre los labios del reten
Ritzel; Zahnrad Pinion; Toothed gear Pignon; Roue d'engrenage Pinon; Rueda de engranaje	3 23		11g	Zähne füllen, fetten Fill teeth, grease remplir les dents, graisser Llenar dientes, engrasar

Schmierstelle Lubrication point Point de lubrification Punto de lubricacion	Fig./Pos.	Schmierstoff Fett Öl Lubricant grease oil Lubrifiant graisse huile Lubricante grasa aceite	Mengen Quantity Quantite Cantidad	Schmierstoffvorschrift Lubricating instructions Indications de graissage Instrucciones de lubricacion
O-Ring O-ring joint torique antillo toroidal	54; 56 58; 59 60	SAE 20 W Mineralöl, handelsüblich Mineral oil, standard / Huile minerale en vente dans le comerc Aceite usual en el comercio		in Öl tauchen; 3 h in Öl legen insert in oil; lay in oil for 3 h le plonger dans l'huile; le poser 3 h sumergir en aceite; poner 3 h en aceit
Teile Parts Pieces Piezas	27 35			einölen; in Öl tauchen oil; dip in oil huiler le plonger dans l'huile engrasar con aceite; sumergir en aceite

*sofern Lager ungefettet
 if bearing is unlubricated
 si roulement n'est pas graisse
 en caso de que el rodamiento esta son grasa

Prüfwerte 0 611 213 0 .. = **GBH 24 V** Stand / Issue: **99-07**
Testing values 0 611 213 1 .. = **GBH 24 VR**
Valeurs de vérification 0 611 213 7 .. = **GBH 24 VRE**
Valores de control

Spannung Voltage Voltage Voltaje	Leerlauf no-load running marche à vide marcha en vacío		Widerstand (20°C/ 68°F) resistance résistance resistencia		Zulässige Übertemperatur im Leerlauf admissible over temperature at no-load élévation admissible de température à vide sobretemperatura admisible en vacío		
Typ V	Stromaufnahme current consumption courant absorbé absorción de corriente A	Spindeldrehzahl speed of spindle vitesse de la broche velocidad del husillo 1/min - rpm - t/mn - rpm Stufe	des Ankers of rotor du rotor del rotor Ω	einer Feldspule of one stator coil d'une bobine du stator de una bobina del estator Ω	Motor motor moteur motor °C	Getriebe gear engrenage engrenaje °C	Arbeitsspindel spindle broche husillo °C
0 611 213 0 .. 22	6.575 - 10.425	- 565 - 835	0.172 - 0.247	0.000 - 0.000	15	10	25
0 611 213 1 .. 22	6.575 - 10.425	- 565 - 835	0.172 - 0.247	0.000 - 0.000	15	10	25
0 611 213 7 .. 22	5.600 - 10.400	- 567 - 763	0.172 - 0.247	0.000 - 0.000	15	10	25

Bemerkung: Überrasstmoment der Kupplung 12 - 20 Nm. Bei nicht erreichen von 12 Nm, Kupplung ersetzen.
 For your notice: Slipping point of clutch 12 - 20 Nm. Under 12 Nm replace clutch.

Kollektor-Mindestdurchmesser: mm
 Minimum diameter of commutator:
 Diamètre minimum du collecteur:
 Diámetro mínimo del colector:

Kohlebürsten-Mindestlänge: = X Abschaltkohlen
 Minimum length of brushes:
 Longueur minimale des balais:
 Longitud mínima de las escobillas: cut-off brushes
 charbon rupteur
 charbón de desconexión

Änderungen vorbehalten

Unsere Erzeugnisse werden stets dem neuesten technischen Stand angepaßt. Deshalb müssen wir uns Änderungen von technischen Daten vorbehalten.

Modifications

Our products are constantly modified to meet new technical standards. We therefore reserve the right to alter data and specifications without prior notice.

Modifications

Nos produits sont continuellement adaptés aux dernières nouveautés techniques et les dates sont données sous réserve de changement.

Modificaciones

Nuestros fabricados van siendo adaptados constantemente a las últimas conquistas técnicas. Por ello, tenemos que reservarnos el derecho de introducir modificaciones en los datos técnicos.