

# BOSCH



## Service



**INSTANDSETZUNGSHINWEISE**  
**REPAIR INSTRUCTIONS**  
**INSTRUCTIONS DE REPARATION**  
**INSTRUCCIONES DE REPARACION**

EW / WJW 0 611 261 ... (2005-04)

**Bohrhammer**  
**Rotary Hammer**  
**Marteau perforateur**  
**Martillo perforador**

Typ 0 611 261 5 .. = GBH 24 VFR  
Typ 0 611 261 7 .. = GBH 24 VFR

**Änderungen vorbehalten.** Unsere Erzeugnisse werden stets dem neuesten technischen Stand angepaßt. Deshalb behalten wir uns Änderungen vor.

**Modifications.** Our products are constantly modified to meet new technical standards. We therefore reserve the right to alter data and specifications without prior notice.

**Modifications.** Nos produits sont continuellement adaptés aux dernières nouveautés techniques et les dates sont données sous réserve de changement.

**Modificaciones.** Nuestros fabricados van siendo adaptos constantemente a las últimas conquistas técnicas. Por ello, tenemos que reservarnos el derecho de introducir modificaciones en los datos técnicos.

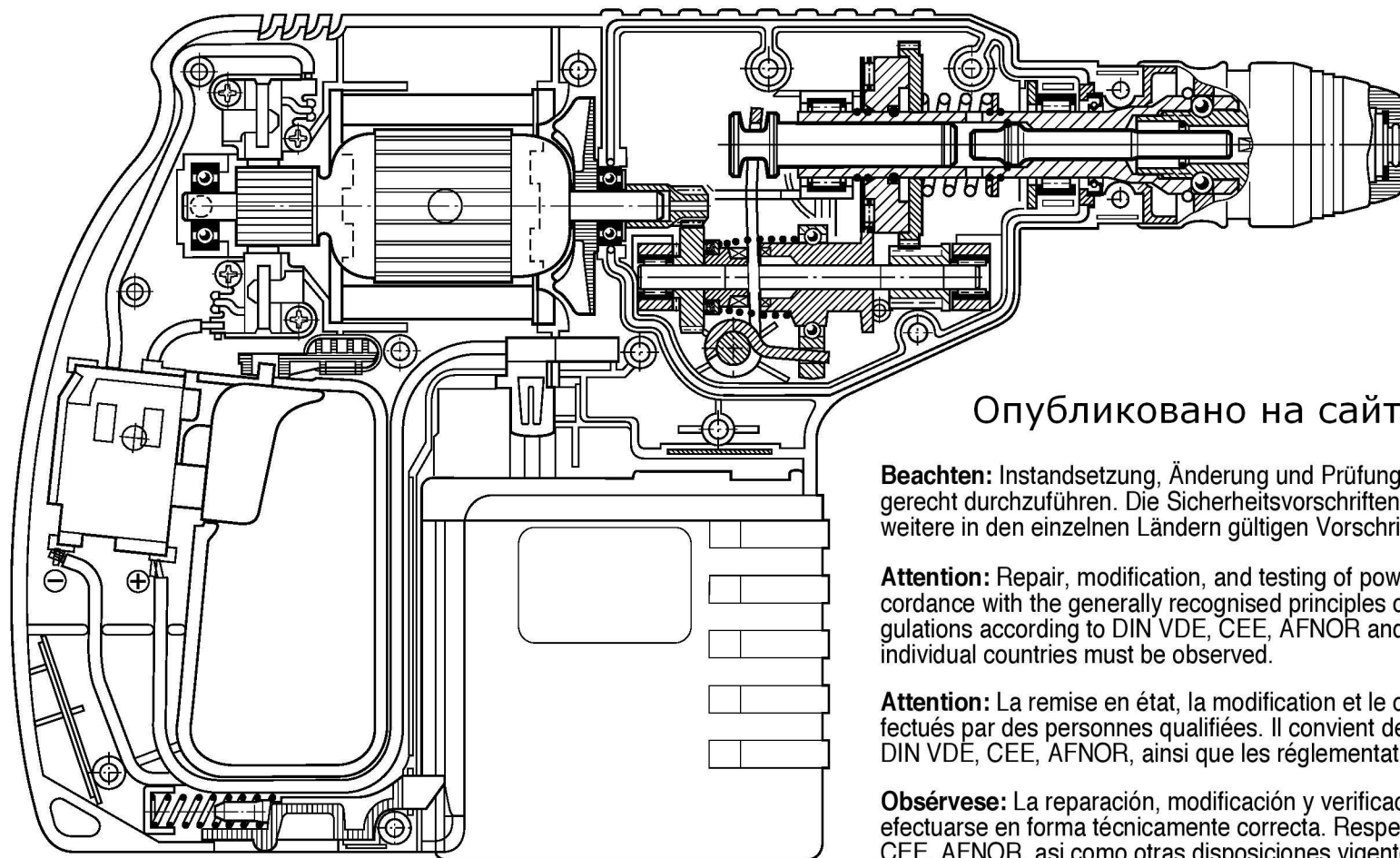

Опубликовано на сайте [www.rem-5.ru](http://www.rem-5.ru)

**Beachten:** Instandsetzung, Änderung und Prüfung von Elektrowerkzeugen sind fachgerecht durchzuführen. Die Sicherheitsvorschriften nach DIN VDE, CEE, AFNOR und weitere in den einzelnen Ländern gültigen Vorschriften sind einzuhalten.

**Attention:** Repair, modification, and testing of power tools must be carried out in accordance with the generally recognised principles of engineering practise. Safety regulations according to DIN VDE, CEE, AFNOR and further regulations applicable in individual countries must be observed.

**Attention:** La remise en état, la modification et le contrôle des outils électriques doivent être effectués par des personnes qualifiées. Il convient de respecter les prescriptions de sécurité selon DIN VDE, CEE, AFNOR, ainsi que les réglementations en vigueur dans le pays concerné.

**Obsérvese:** La reparación, modificación y verificación de herramientas eléctricas mano debe efectuarse en forma técnicamente correcta. Respetar las normas de seguridad según DIN VDE, CEE, AFNOR, así como otras disposiciones vigentes en los distintos países.

ROBERT BOSCH GMBH    GESCHÄFTSBEREICH ELEKTROWERKZEUGE    D 70745 LEINFELDEN-ECHTERDINGEN

Printed in Federal Republic of Germany - Imprimé en République Fédérale d'Allemagne

Typ 0 611 261 ...

11 261 - D01

1.

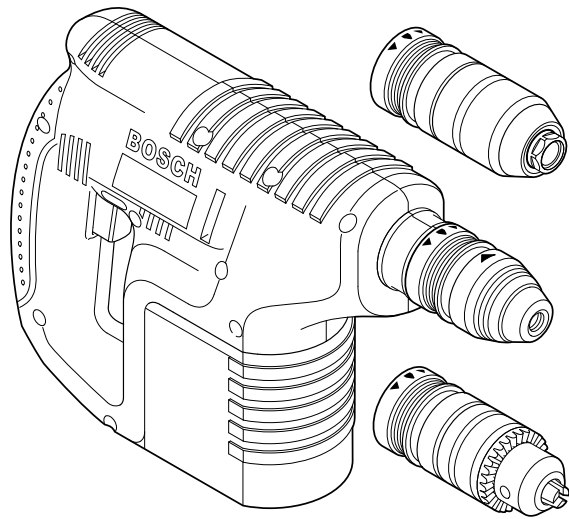

2.

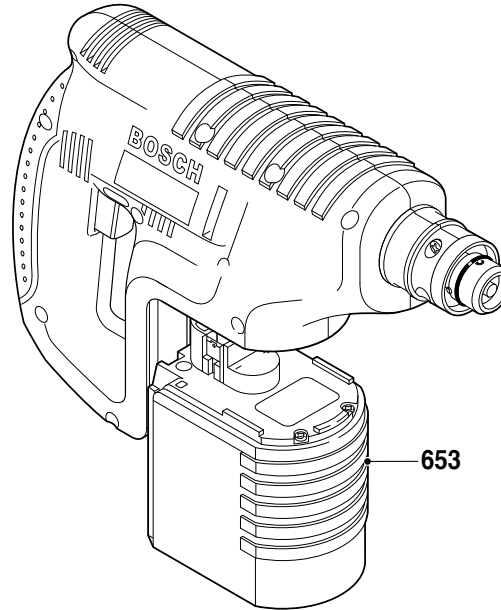

### Zerlegen

Für die Demontage werden handelsübliche Werkzeuge benötigt.  
Zerlegen nach Explosions-, Schnittzeichnung und diesem Instandsetzungshinweis.

### Disassembly

Use normal trade tools by disassembly.  
Disassembly using explosion-, cut-away drawings and these repair instructions!

### Démontage

Pour le démontage, des outils en usage dans le commerce sont nécessaires.  
Démontez l'appareil suivant la vue éclatée, le plan en coupe et ces instructions de réparation.

### Desmontaje

Para el desmontaje no se precisan herramientas especiales.  
Realizar el desmontaje conforme a los dibujos en perspectiva y en sección, y a estas instrucciones de reparación.

3.

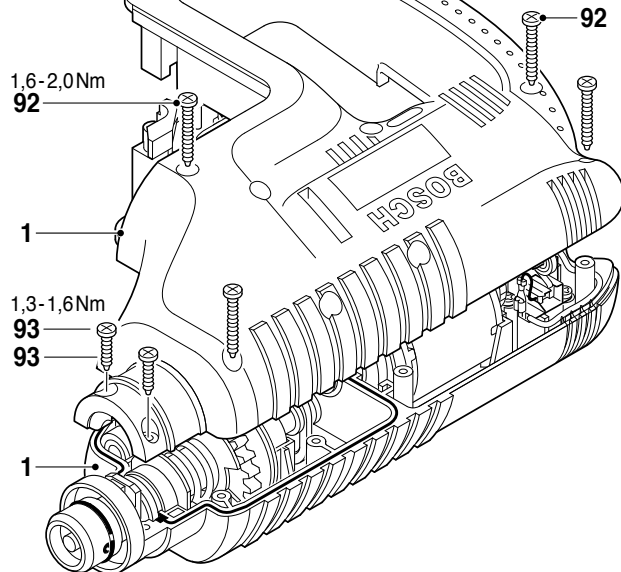

3.1

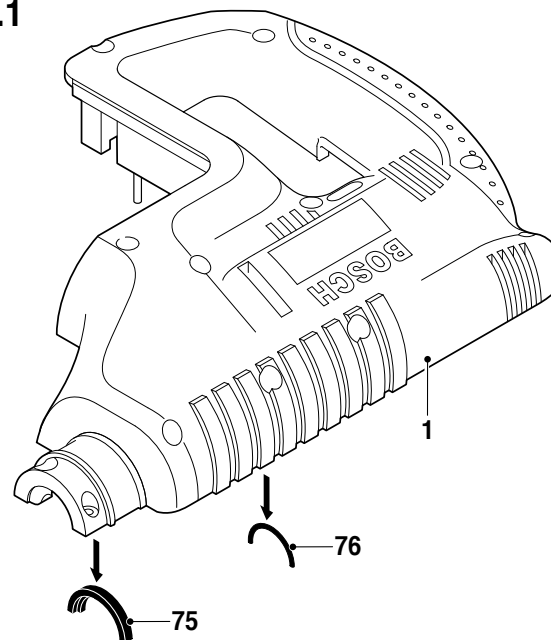

3.2

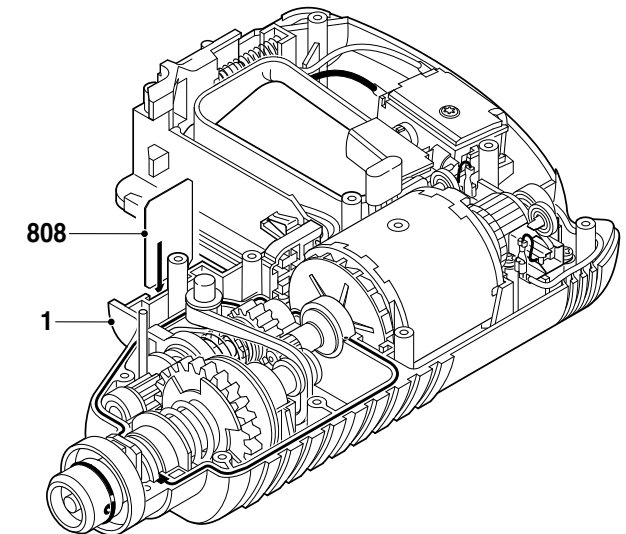

4.

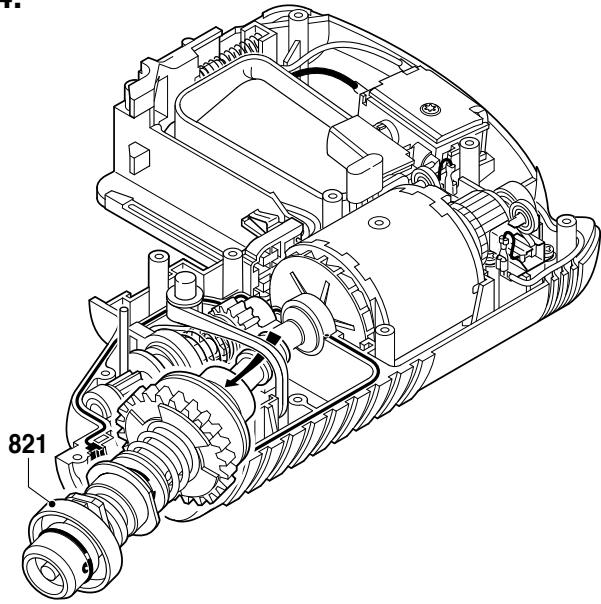

4.1

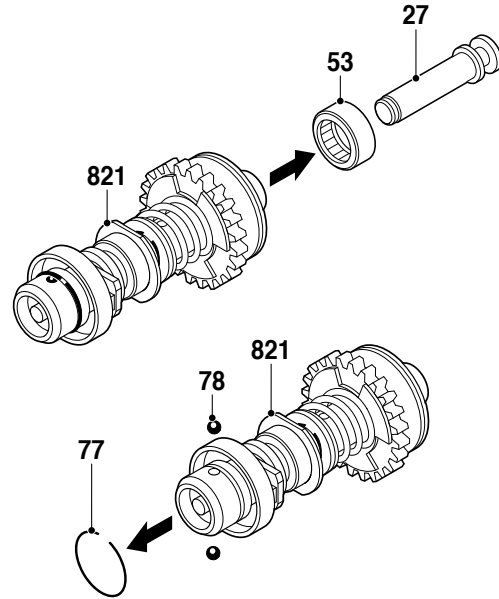

5.

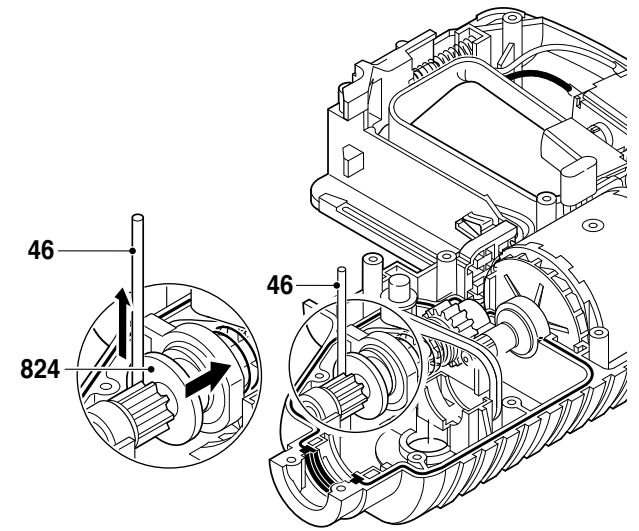

5.1

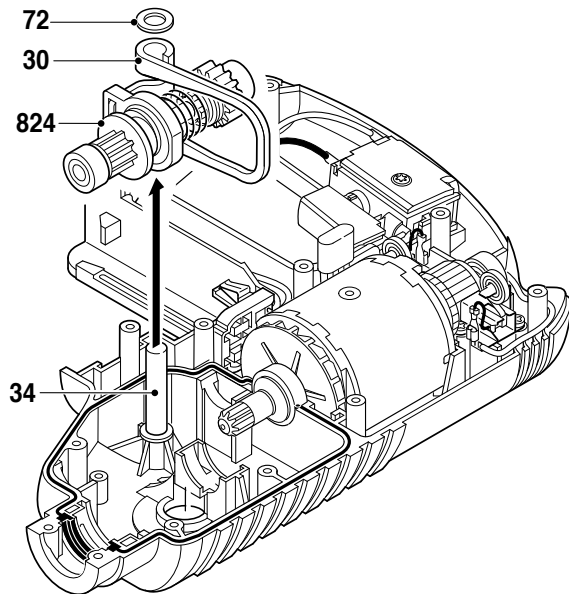

5.2

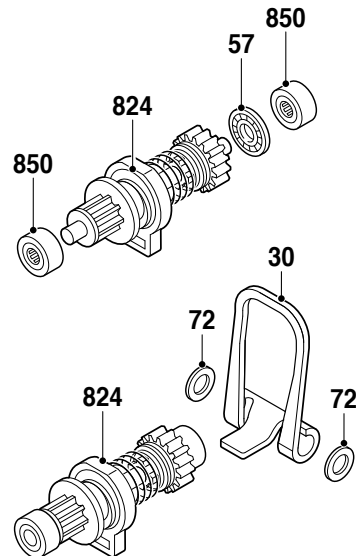

6.

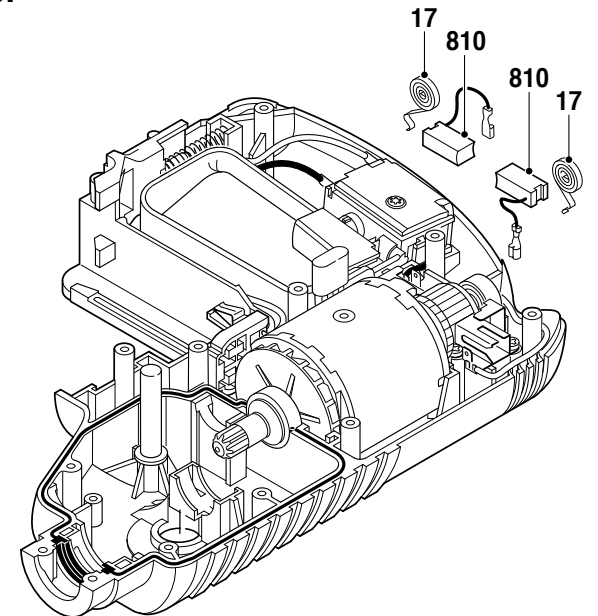

7.

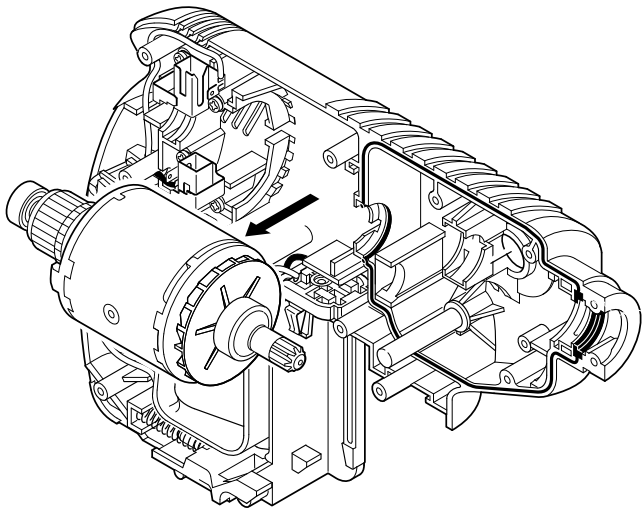

7.1

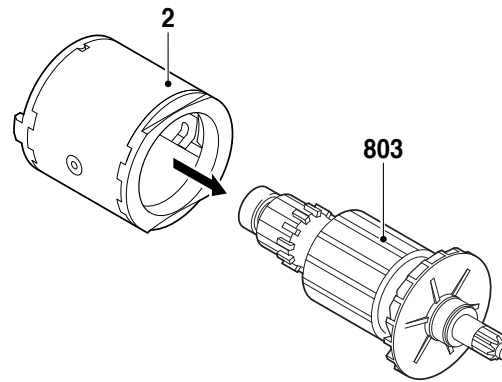

7.2

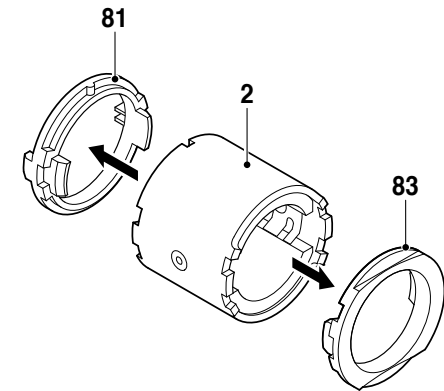

8.

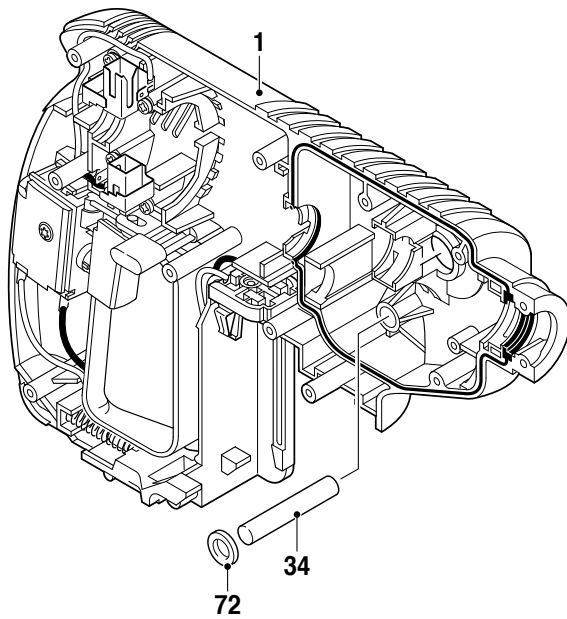

8.1

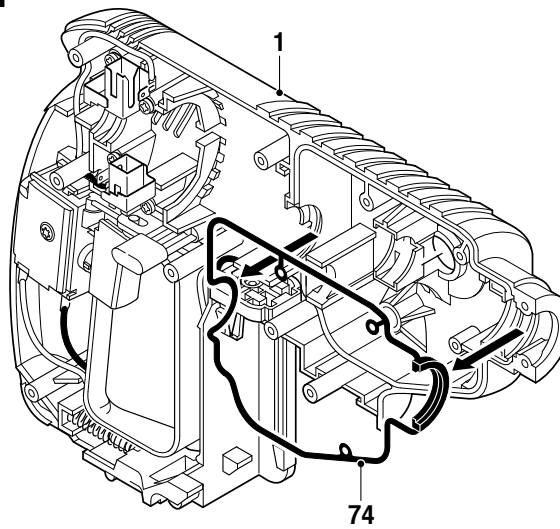

8.2

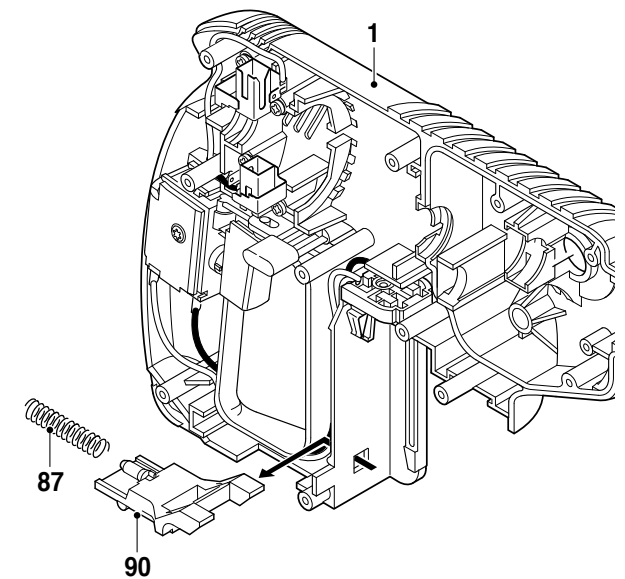

9.

Beachten Pos. 47  
Attention pos. 47

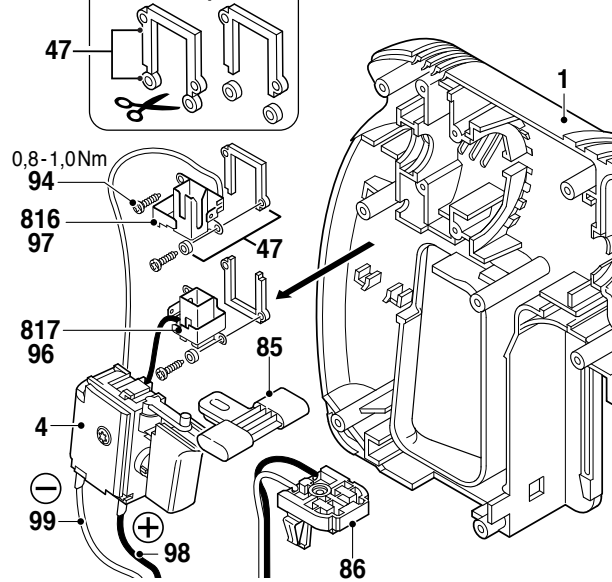

10.

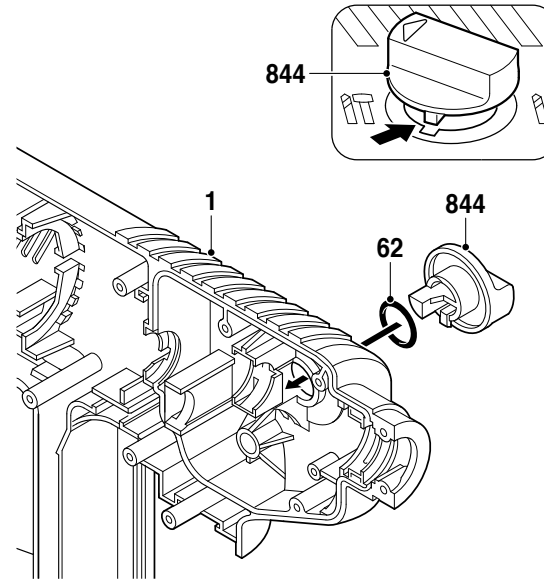

10.1

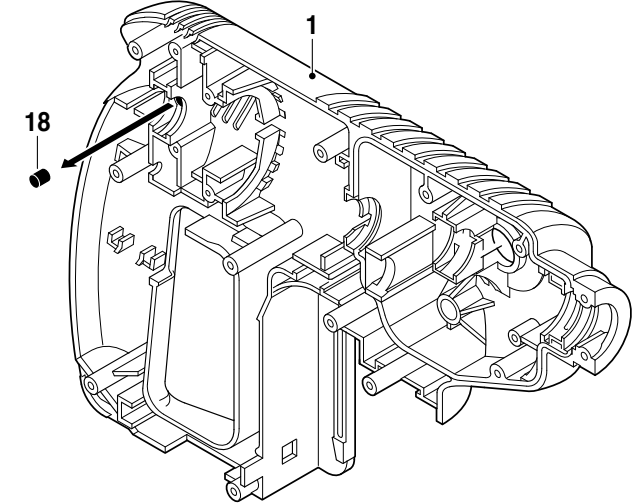

11.

Montagedorn  
Mounting pin  
Arbre de montage  
Punzón de montaje

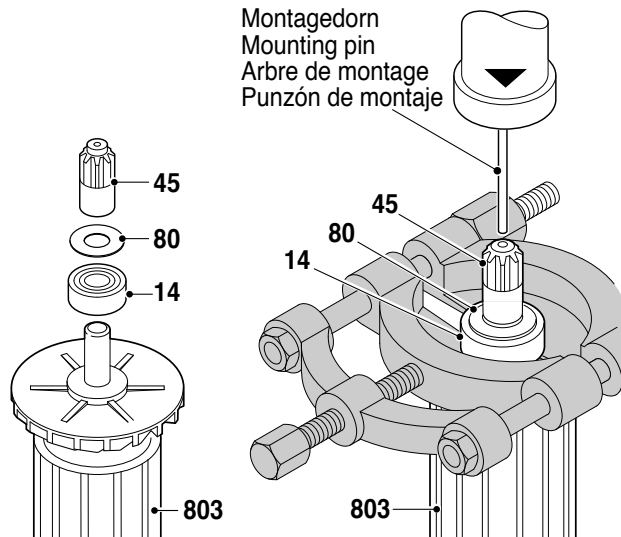

11.1

Montagedorn  
Mounting pin  
Arbre de montage  
Punzón de montaje

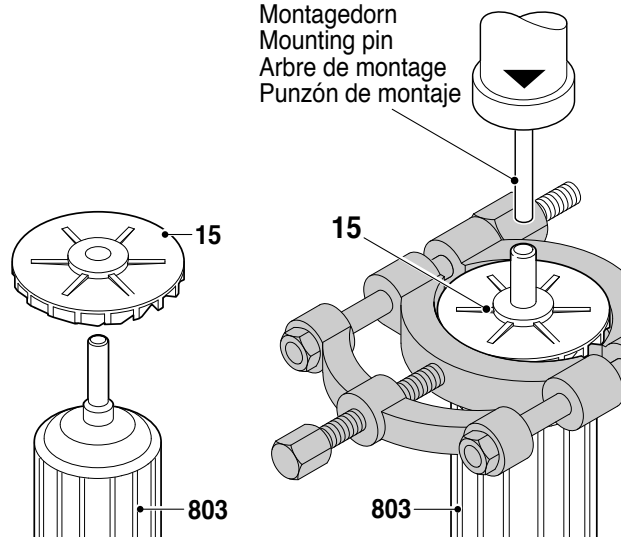

11.2

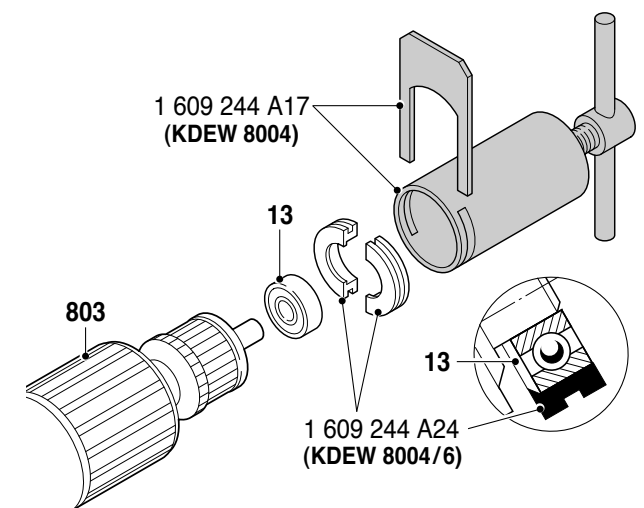

### Zusammenbau

Montage nach Explosionszeichnung und diesem Instandsetzungshinweis.

Alle Teile sind gereinigt, abgenutzte und beschädigte Teile werden ersetzt.

Nur Original-Ersatzteile verwenden.

Zähne aller Zahnräder mit Fett **1 615 430 002** bestreichen.

Bitte Schmierhinweise beachten!

### Assembly

Assembly using explosion drawings and these repair instructions!

Clean all parts, replace worn-out and damaged parts.

Use only original spare parts!

Grease all gear teeth **1 615 430 002**.

Please note lubrication instructions!

### Montage

Le montage s'effectue selon la vue éclatée et les instructions de réparation suivantes.

Toutes les pièces sont nettoyées, les pièces usées ou endommagées doivent être remplacées par des nouvelles. Pour le remplacement de pièces, n'utiliser que des pièces d'origine.

Les dents graisser **1 615 430 002**.

Respecter les instructions de graissage!

### Montaje

Realizar el montaje conforme a los dibujos en perspectiva y a estas instrucciones de reparación.

Todas las piezas deben estar limpias. Las piezas desgastadas o dañadas deben reemplazarse por piezas nuevas. Utilizar solamente piezas de repuesto originales.

Dientes engrasar **1 615 430 002**.

Observar las instrucciones de lubricación!

21.

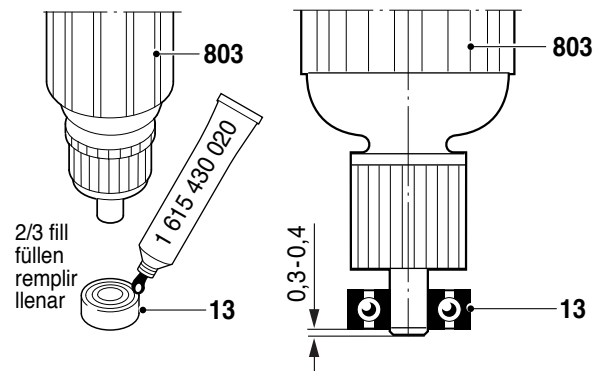

21.1

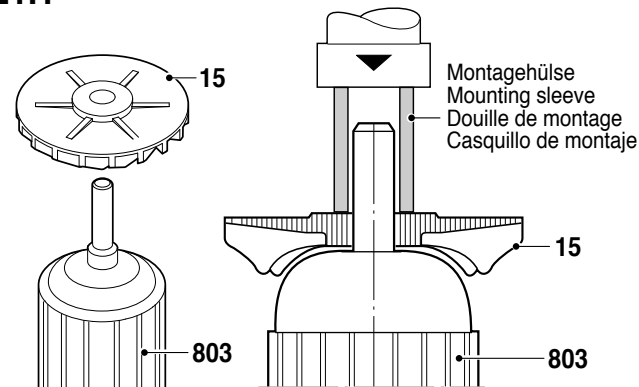

21.2

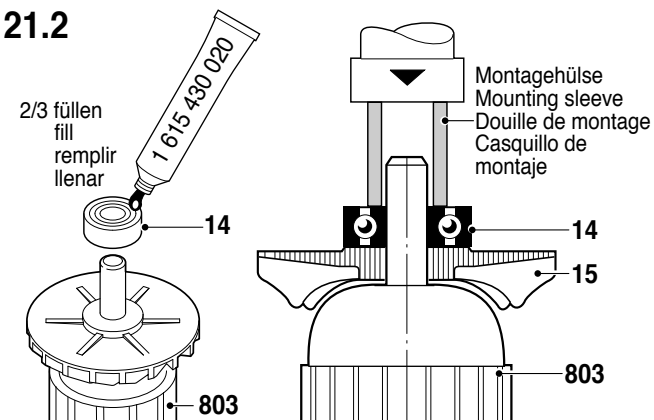

21.3

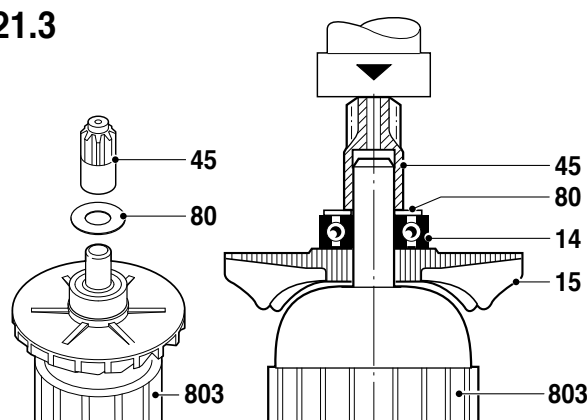

21.4

Einbaumaß beachten!  
Observe correct installation tolerance!  
Attention à la cote de montage!  
Obsérvese la medida de montaje!

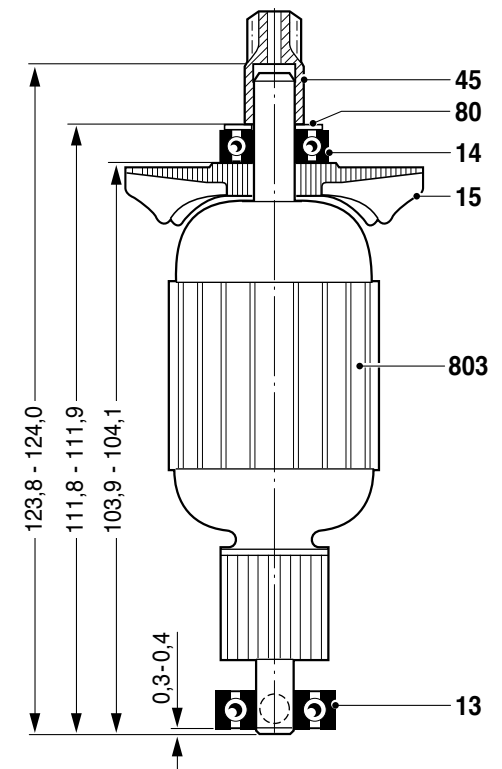

22.

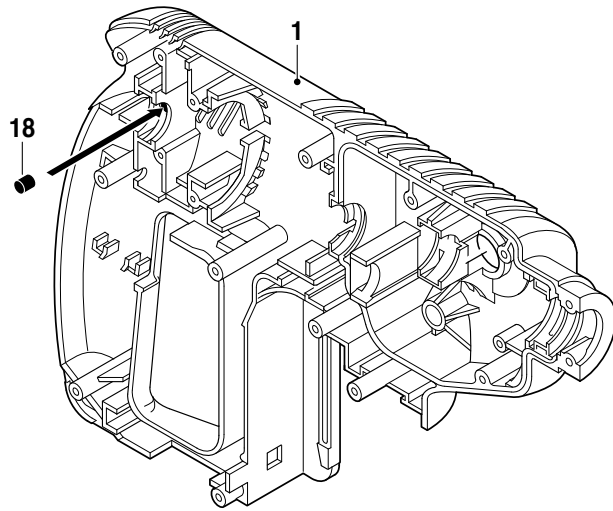

22.1

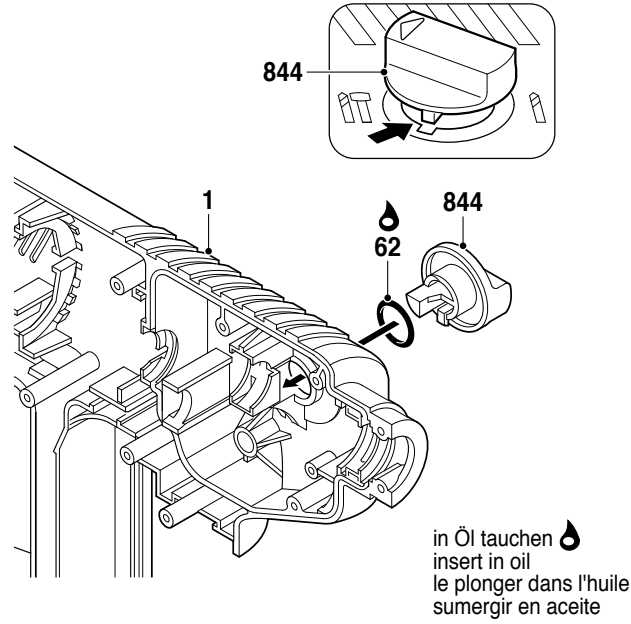

23.

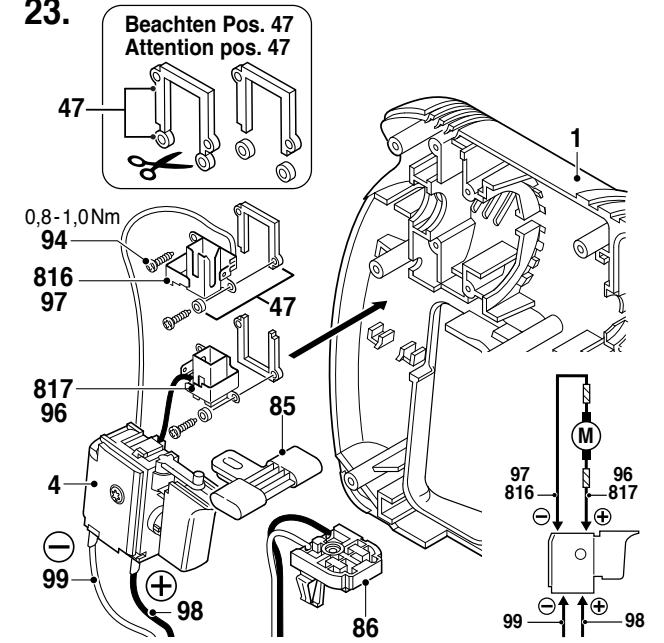

24.

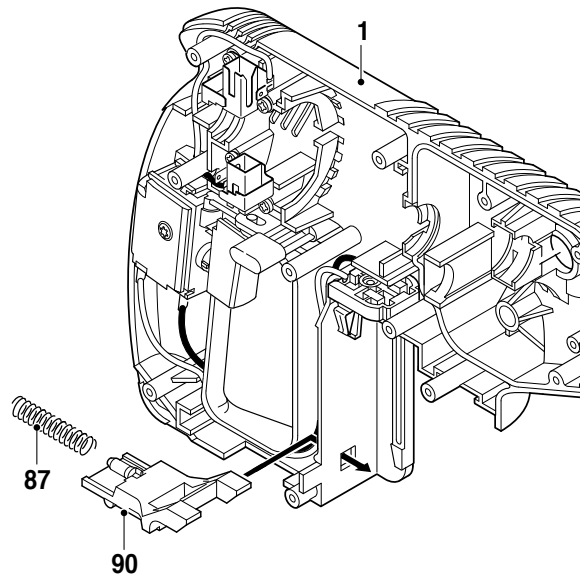

24.1

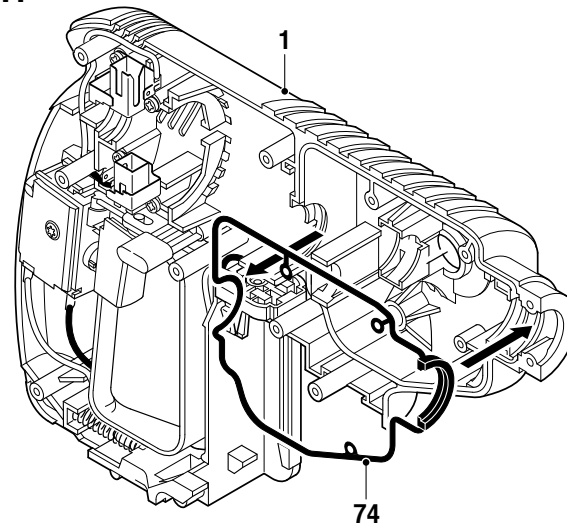

24.2

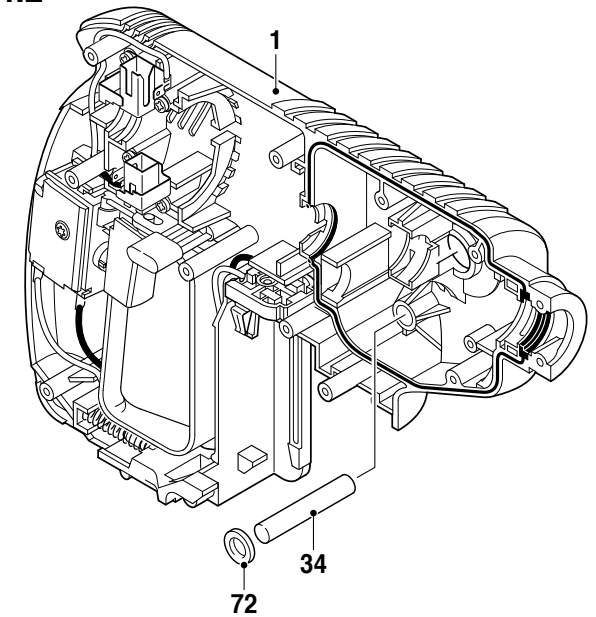

25.

Einbaulage beachten  
Check installation position  
Attention au positionnement  
Téngase en cuenta  
la posición de montaje

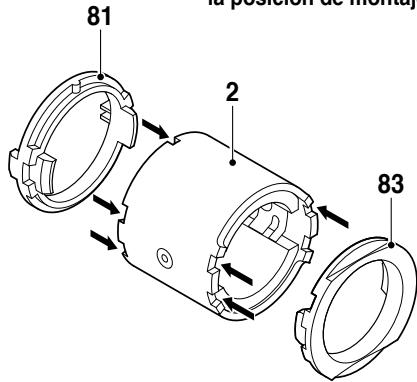

25.1

Einbaulage beachten  
Check installation position  
Attention au positionnement  
Téngase en cuenta  
la posición de montaje

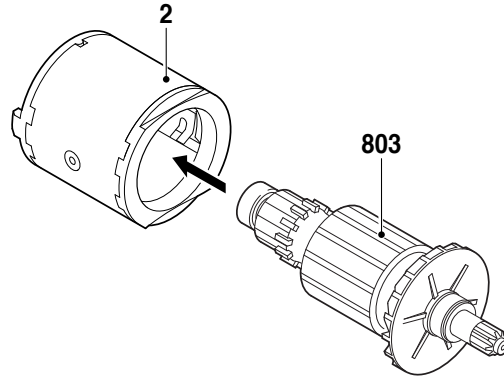

25.2

Einbaulage beachten  
Check installation position  
Attention au positionnement  
Téngase en cuenta  
la posición de montaje

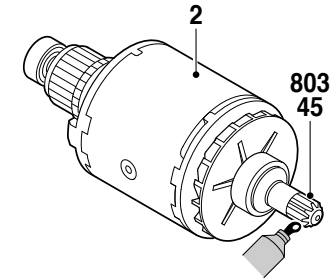

fetten / graisser  
grease / engrasar

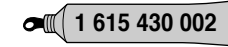

25.3

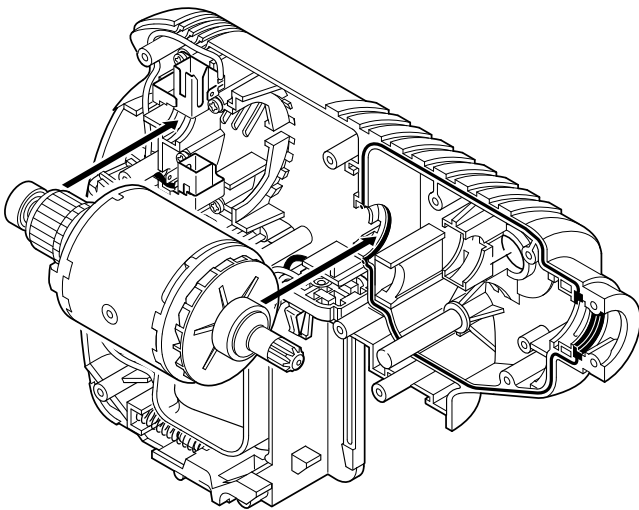

25.4

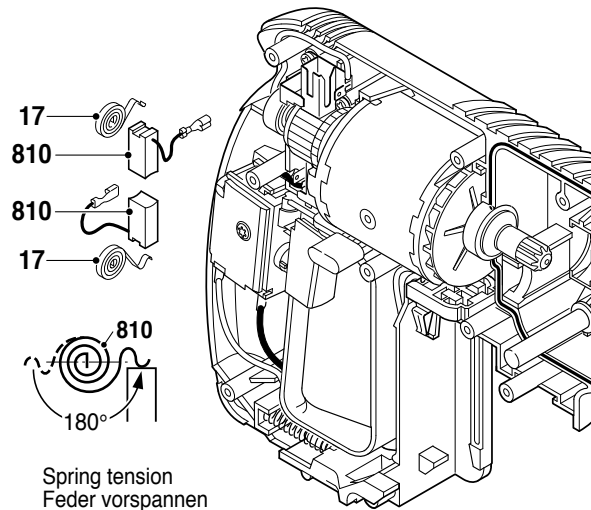

Spring tension  
Feder vorspannen  
Ressort pré-contraint  
Tensión previa del  
muelle

26.

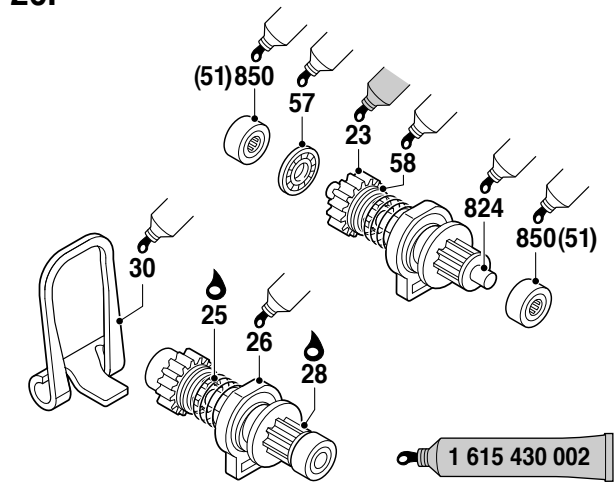

in Öl tauchen  
insert in oil  
le plonger dans l'huile  
sumergir en aceite

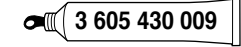
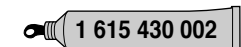

Gleitflächen einstreichen  
Lubricate sliding surfaces  
Enduire les parties mouvantes  
engrasar las piezas móviles



**27.** Teile fetten (45 g); Rest in Getrieberraum.  
Grease the parts (45 g); rest into gear compartment.  
Graisser les pieces (45 g); la graisse restante dans le  
compartiment d'engrenage.  
Engrasar las piezas (45 g); resto en el compartimento  
del engranaje.

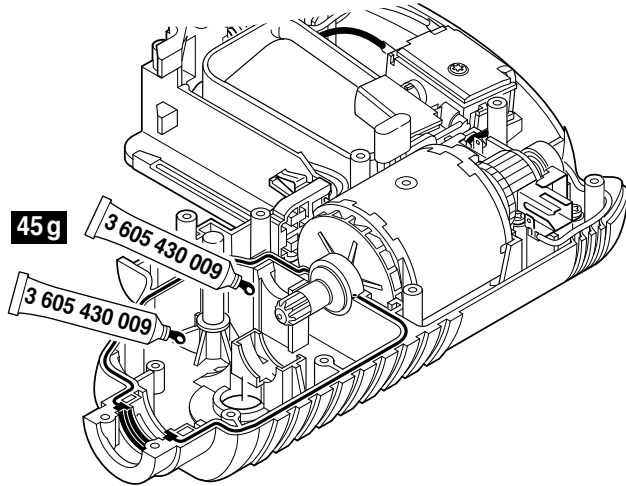

**28.**

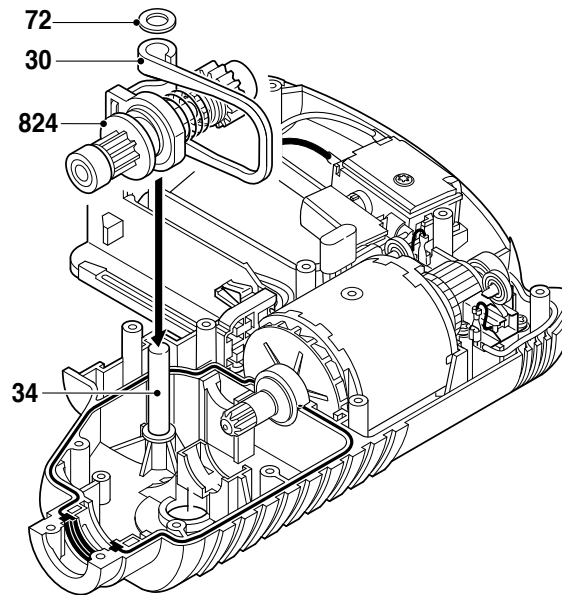

**28.1**

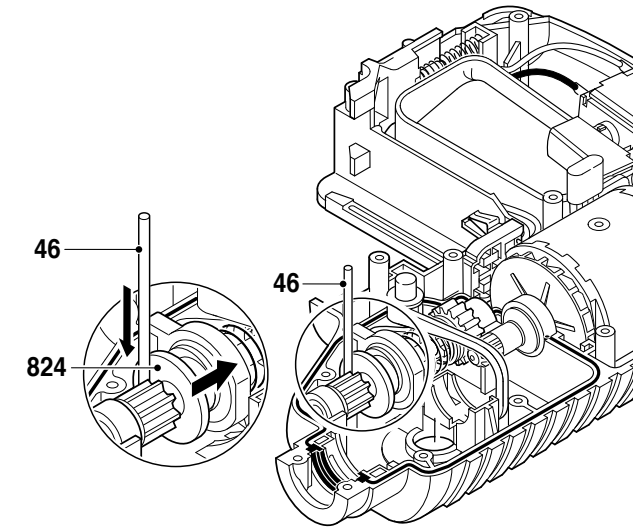

**29.**

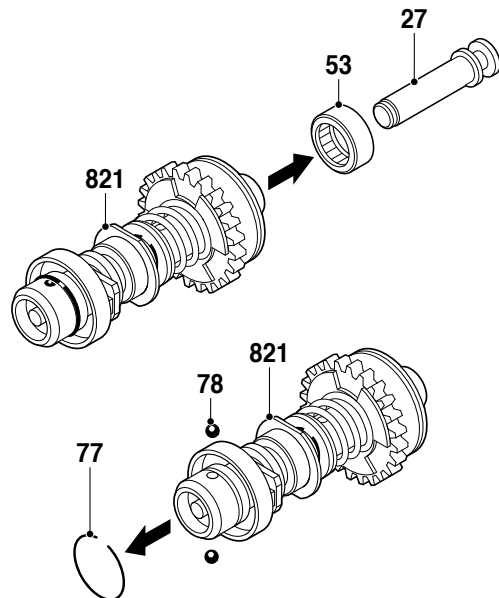

**29.1**

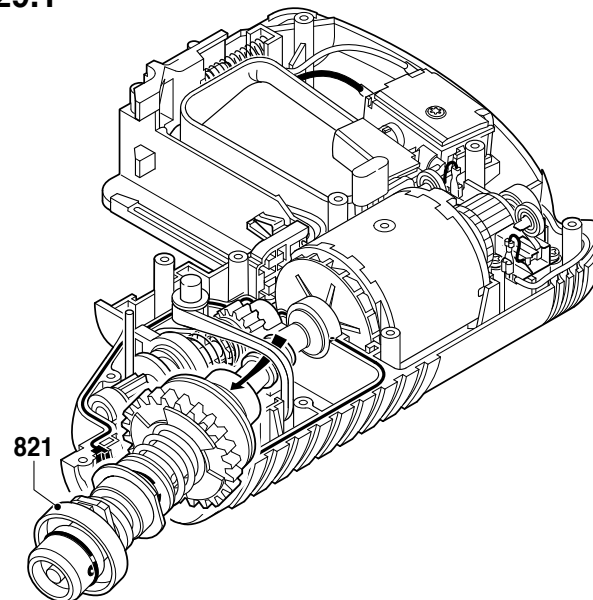

**29.2**

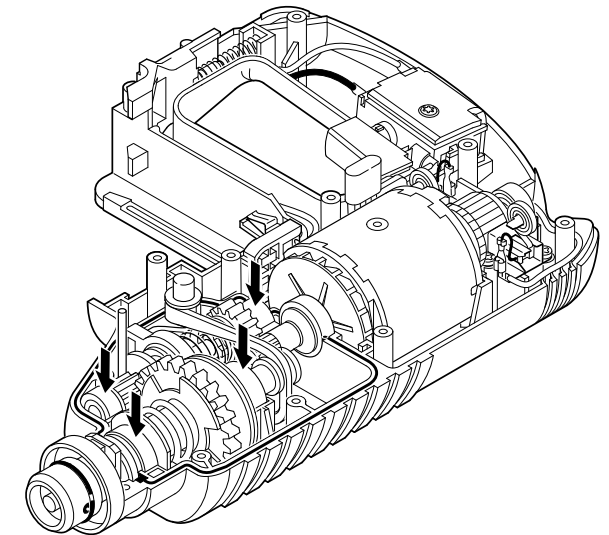

30.

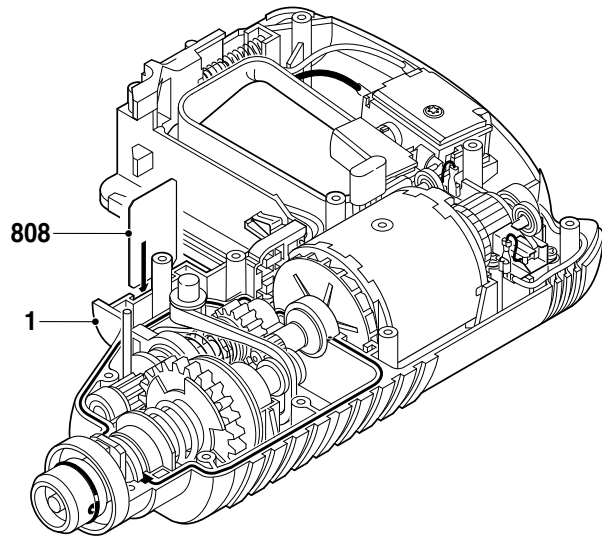

30.1

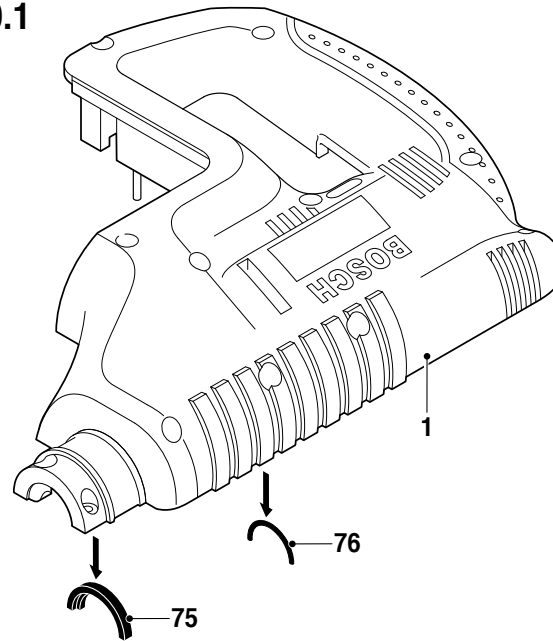

30.2

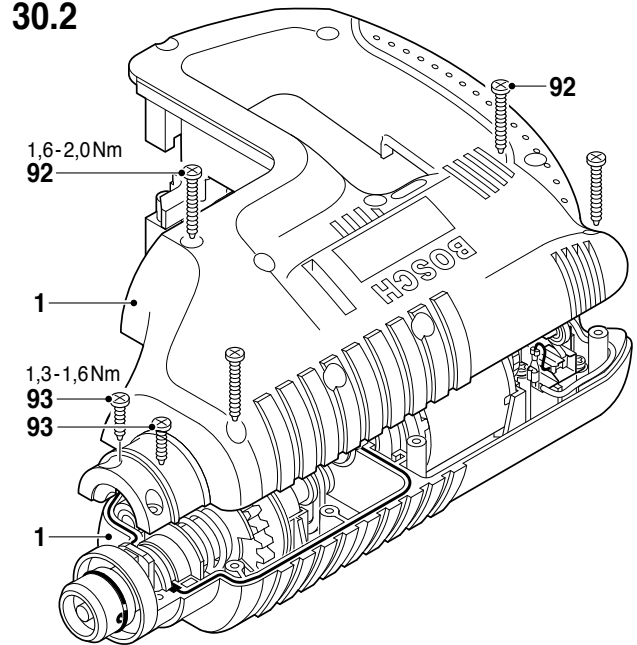

31.

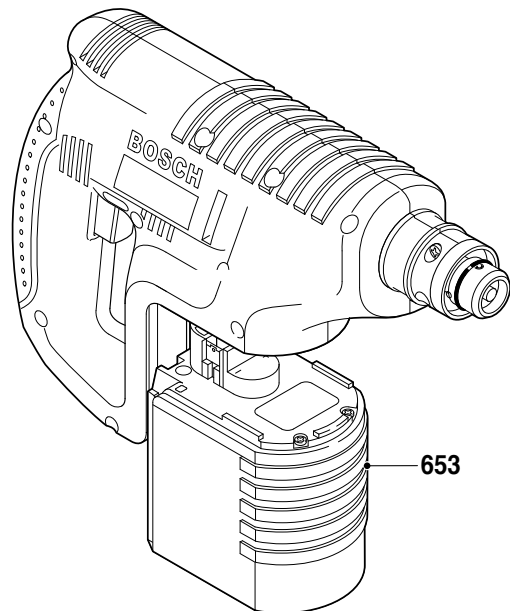

32.

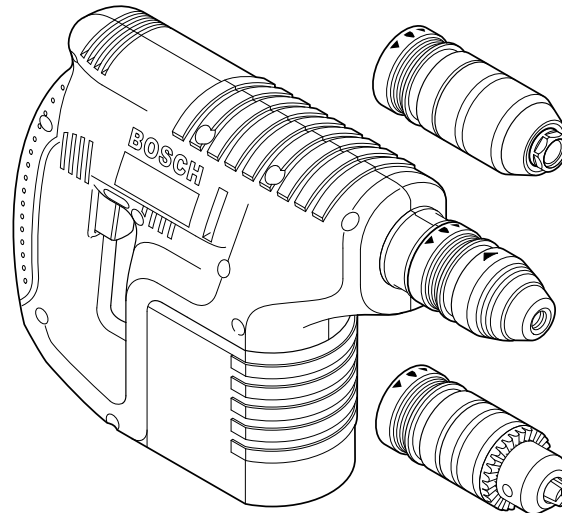

Probelauf, Schlagtest, elektrische und mechanische Prüfung durchführen.

Perform test run, impact test, electrical and mechanical check-up.

Marche à titre d'essai, contrôle de frappe et de perçage, effectuer un contrôle mécanique et électrique.

Realizar un control funcional, una prueba de taladrado con y sin percusión y los ensayos eléctricos y mecánicos correspondientes.

Schmierung 0 611 261 5.. = GBH 24 VFR  
 Lubrication 0 611 261 7.. = GBH 24 VFR  
 Lubrification  
 Lubricacion

Stand / Issue: 2005-04

Änderungen vorbehalten  
 Modifications reserved  
 Modifications réservées  
 Salvo modificaciones

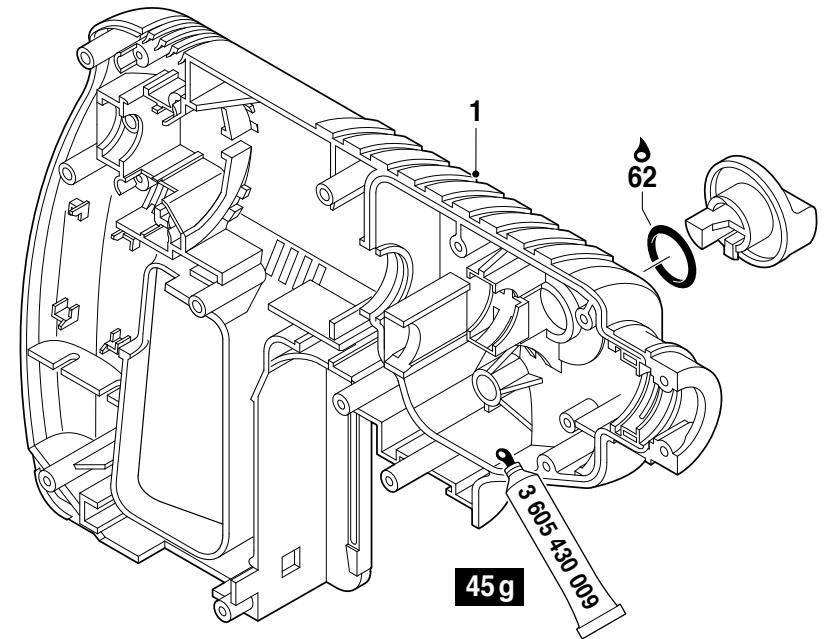
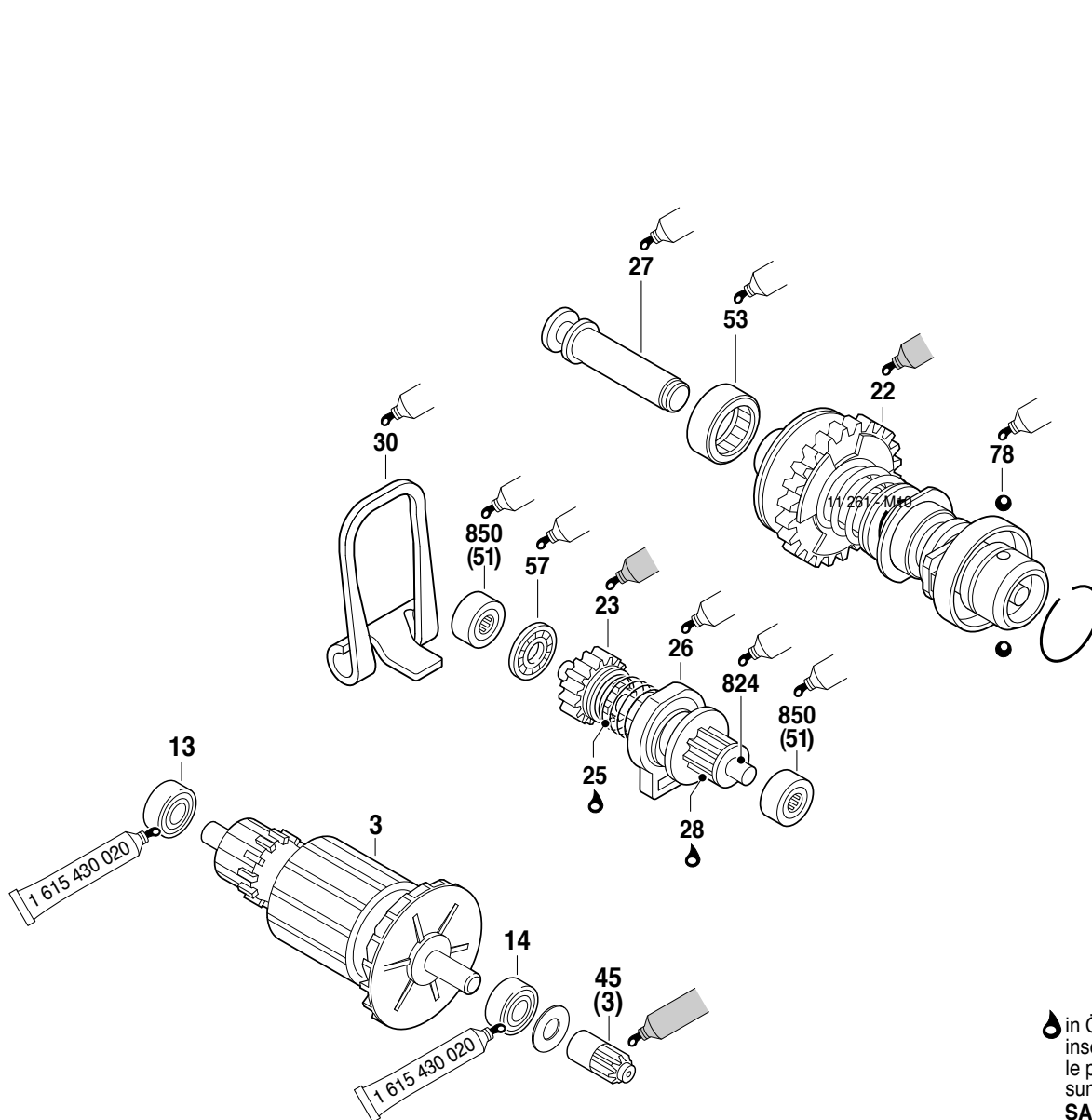

Teile fetten (45 g); Rest in Getrieberaum.  
 Grease the parts (45 g); rest into gear compartment.  
 Graisser les pieces (45 g); la graisse restante dans le  
 compartiment d'engrenage.  
 Engrasar las piezas (45 g); resto en el compartimento  
 del engranaje.

in Öl tauchen  
 insert in oil  
 le plonger dans l'huile  
 sumergir en aceite  
**SAE 20W**

fetten / graissees  
 grease / engrasar  
**3 605 430 009**

fetten / graissees  
 grease / engrasar  
**1 615 430 002**

fetten / graissees  
 grease / engrasar  
**1 615 430 020**

