

BOSCH



Service



**INSTANDSETZUNGSHINWEISE
REPAIR INSTRUCTIONS
INSTRUCTIONS DE REPARATION
INSTRUCCIONES DE REPARACION**

EW / WJW 0 611 216 7.. (99 - 07) X

**Bohrhammer
Rotary Hammer
Marteau perforateur
Martillo perforador**

Typ 0 611 216 7.. = GBH 5-40 DCE

Änderungen vorbehalten. Unsere Erzeugnisse werden stets dem neuesten technischen Stand angepaßt. Deshalb behalten wir uns Änderungen vor.

Modifications. Our products are constantly modified to meet new technical standards. We therefore reserve the right to alter data and specifications without prior notice.

Modifications. Nos produits sont continuellement adaptés aux dernières nouveautés techniques et les dates sont données sous réserve de changement.

Modificaciones. Nuestros fabricados van siendo adaptos constantemente a las últimas conquistas técnicas. Por ello, tenemos que reservarnos el derecho de introducir modificaciones en los datos técnicos.

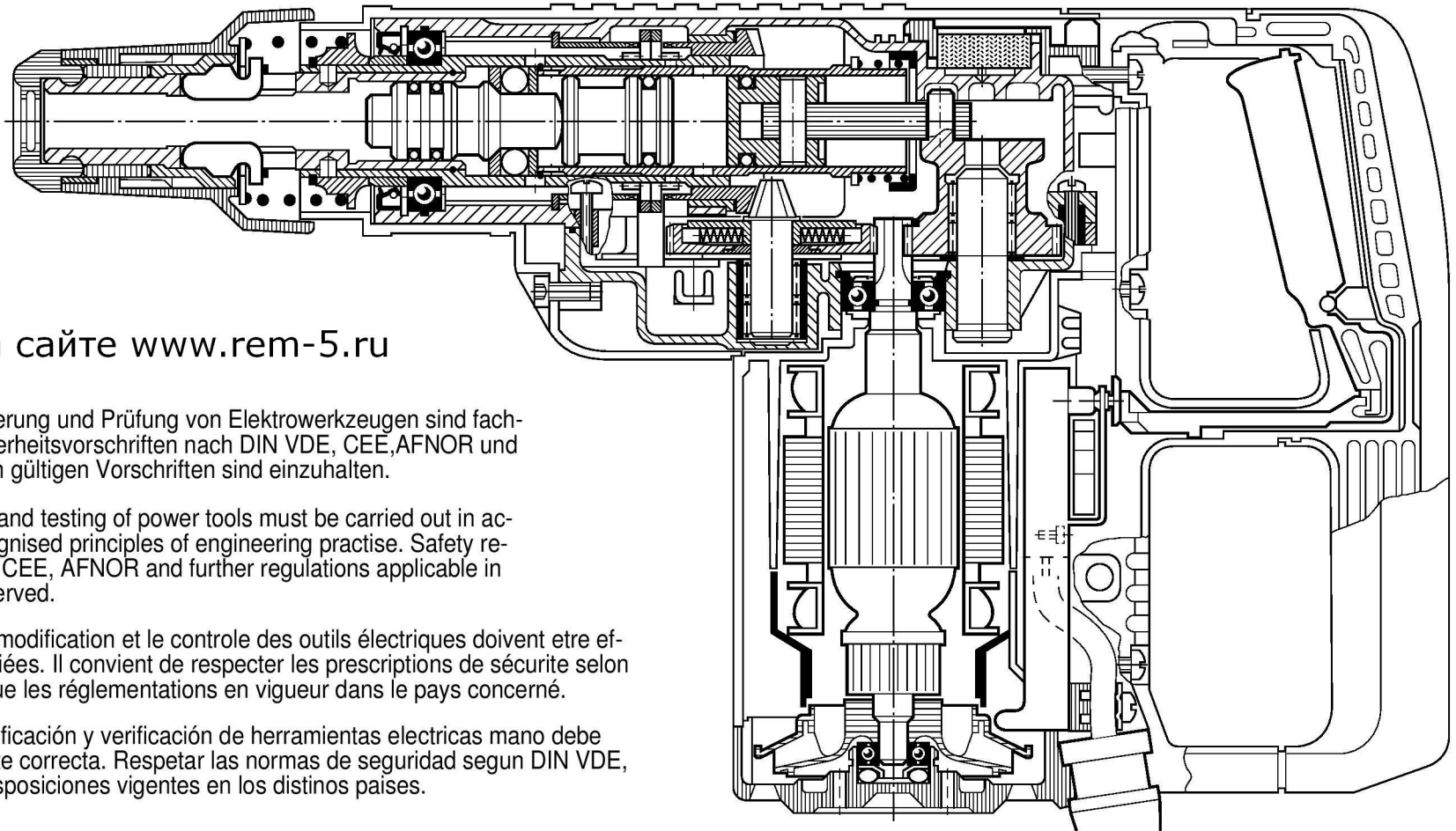

Опубликовано на сайте www.rem-5.ru

Beachten: Instandsetzung, Änderung und Prüfung von Elektrowerkzeugen sind fachgerecht durchzuführen. Die Sicherheitsvorschriften nach DIN VDE, CEE, AFNOR und weitere in den einzelnen Ländern gültigen Vorschriften sind einzuhalten.

Attention: Repair, modification, and testing of power tools must be carried out in accordance with the generally recognised principles of engineering practise. Safety regulations according to DIN VDE, CEE, AFNOR and further regulations applicable in individual countries must be observed.

Attention: La remise en état, la modification et le controle des outils électriques doivent être effectués par des personnes qualifiées. Il convient de respecter les prescriptions de sécurité selon DIN VDE, CEE, AFNOR, ainsi que les réglementations en vigueur dans le pays concerné.

Obsérvese: La reparación, modificación y verificación de herramientas electricas mano debe efectuarse en forma técnicamente correcta. Respetar las normas de seguridad segun DIN VDE, CEE, AFNOR, asi como otras disposiciones vigentes en los distinos paises.

ROBERT BOSCH GMBH GESCHÄFTSBEREICH ELEKTROWERKZEUGE D 70745 LEINFELDEN-ECHTERDINGEN

Printed in Federal Republic of Germany - Imprimé en République Fédérale d'Allemagne

Typ 0 611 216 7..

Zerlegen

Für die Demontage werden handelsübliche Werkzeuge benötigt.

1. Eingangsprüfung durchführen.
Beachten:
Die Sicherheitsvorschriften nach DIN, VDE, CEE, AFNOR und weitere in den einzelnen Ländern gültigen Vorschriften sind einzuhalten.

Disassembly

Use normal trade tools by disassembly.

1. Carry out power supply check.
Attention:
Safety regulations according to DIN, VDE, CEE, AFNOR and further regulations applicable in individual countries must be observed.

Démontage

Pour le démontage, des outils en usage dans le commerce sont nécessaires.

1. Effectuer un contrôle préliminaire.
Attention:
Respecter les instructions de sécurité selon DIN, VDE, CEE, AFNOR et les autres instructions valables dans les pays respectifs.

Desmontaje

Para el desmontaje no se precisan herramientas especiales.

1. Realizar control de recepción.
Atención:
Atenerse a las prescripciones de seguridad según DIN, VDE, CEE, AFNOR y a las prescripciones adicionales específicas que pudieran existir en los respectivos países.

1.

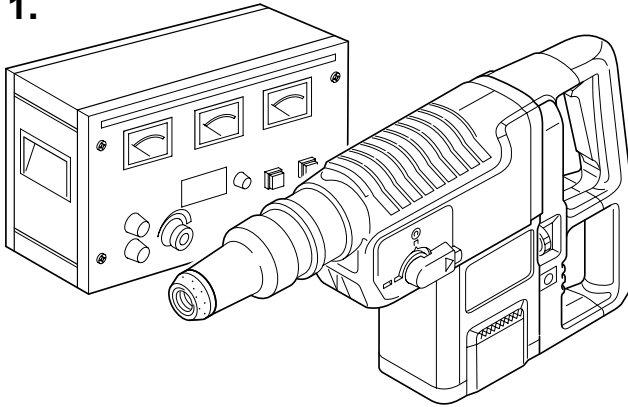

2.

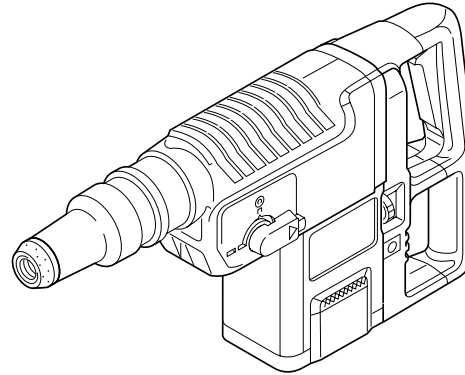

3.

Schutzbacken
Vice jaws

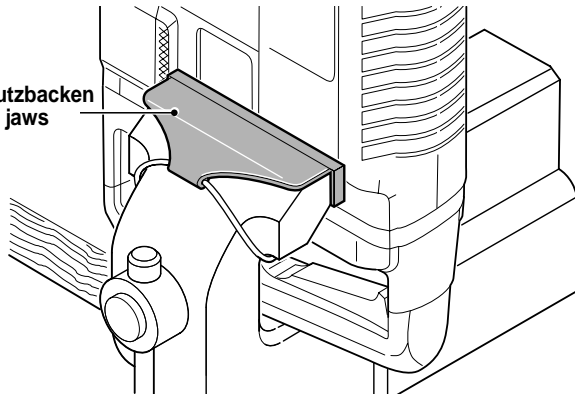

4.

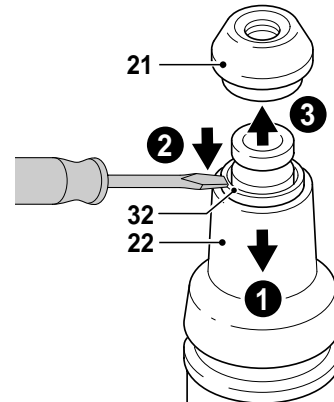

4.1

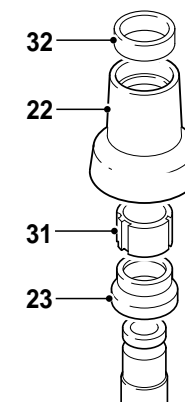

4.2

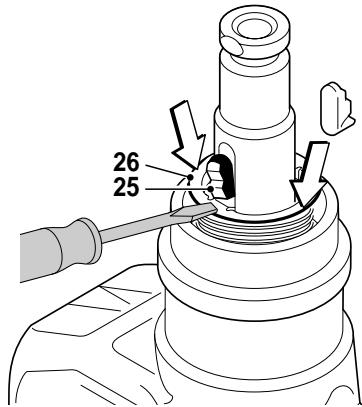

4.3

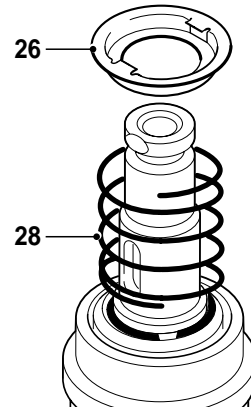

5.

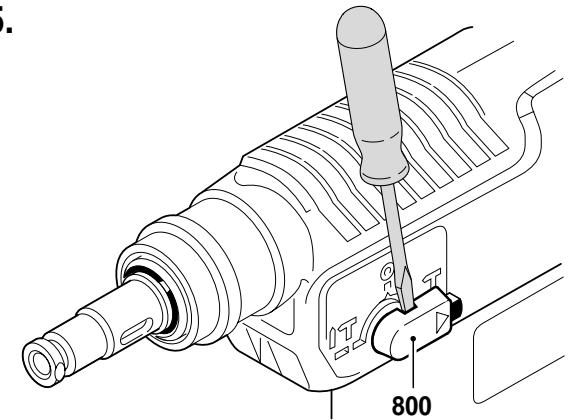

6.

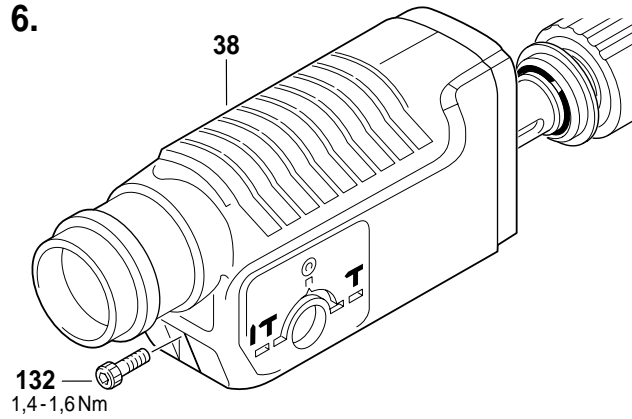

7.

Alte Ausführung Pos. 18; 27; 17
 Old execution
 Ancien exécution
 Vieja ejecución

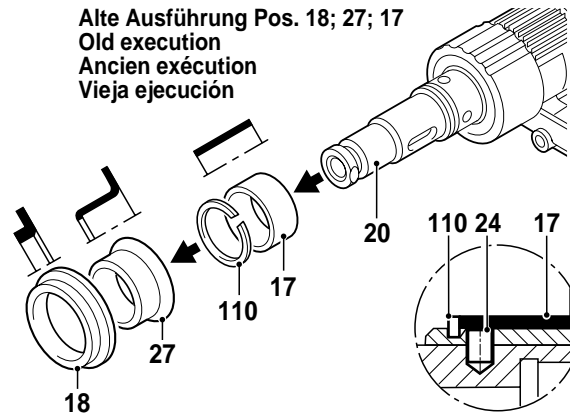

7.1

Neue Ausführung Pos. 27
 New execution
 Nouvelle exécution
 Nueva ejecución

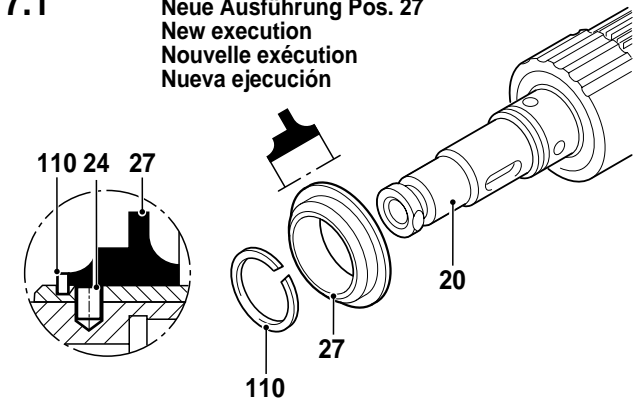

7.2

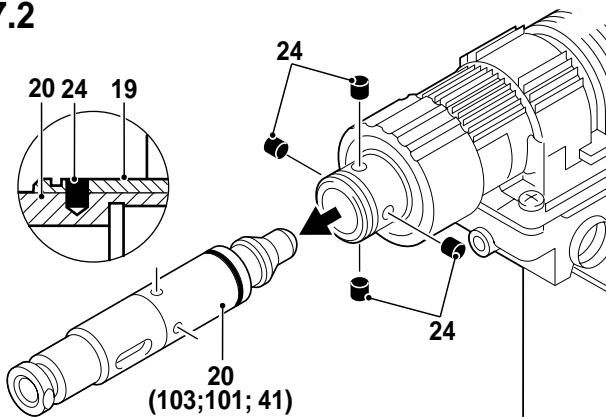

7.3

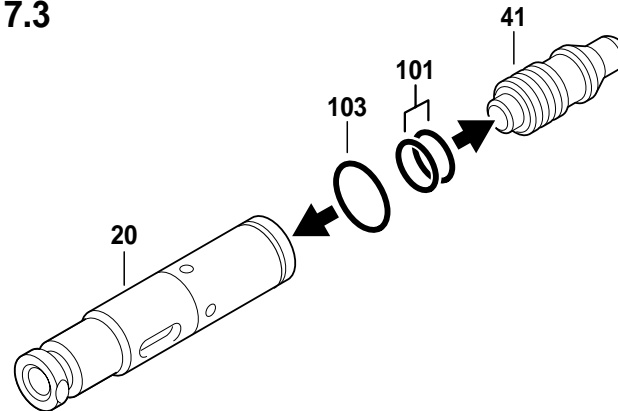

7.4

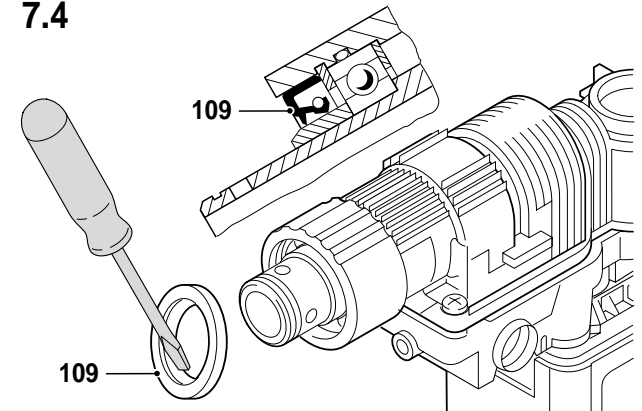

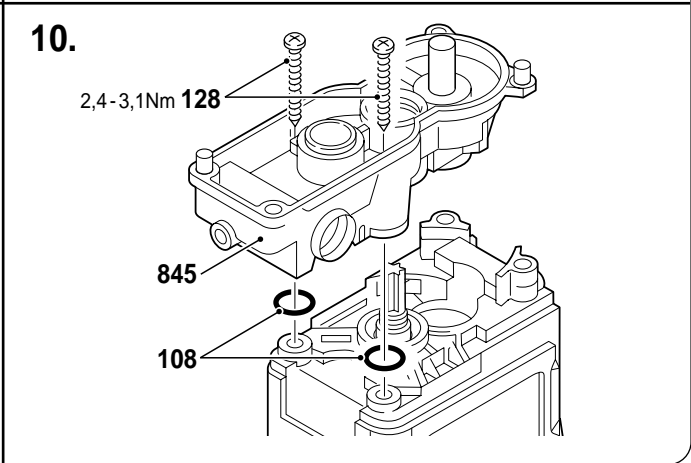
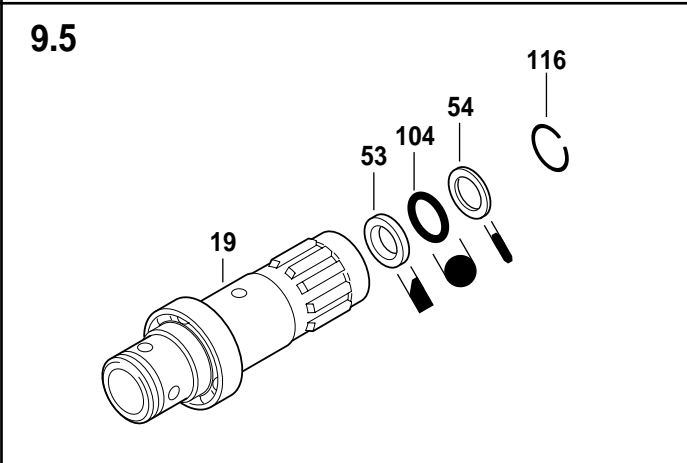
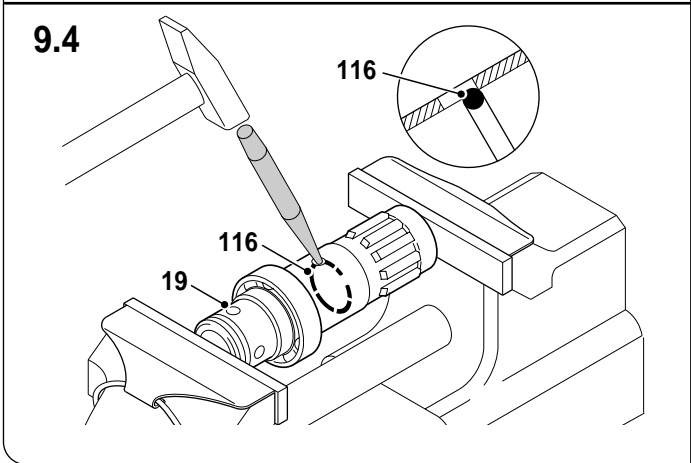
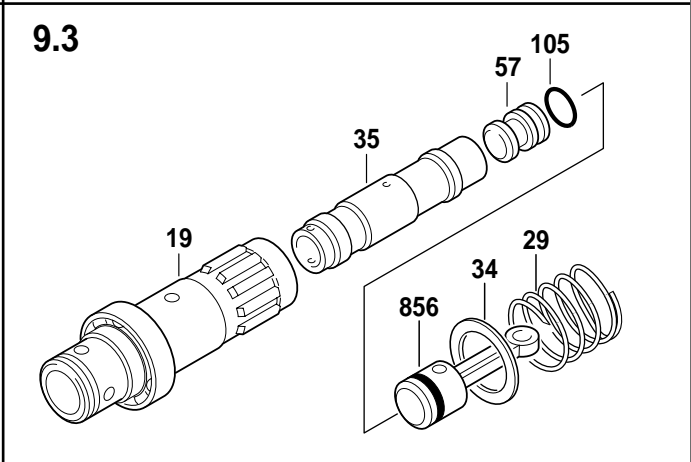
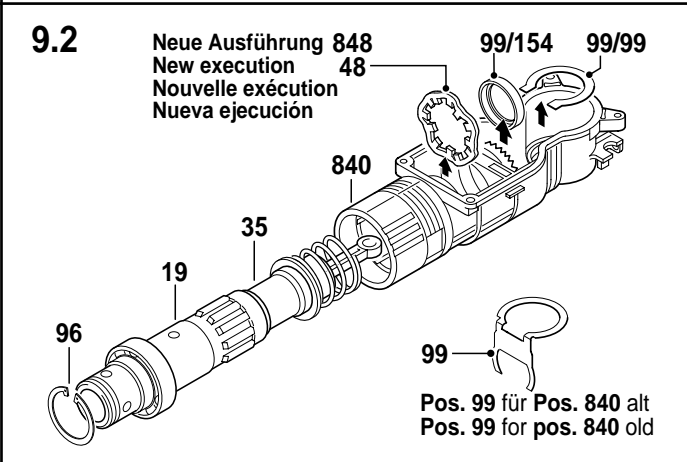
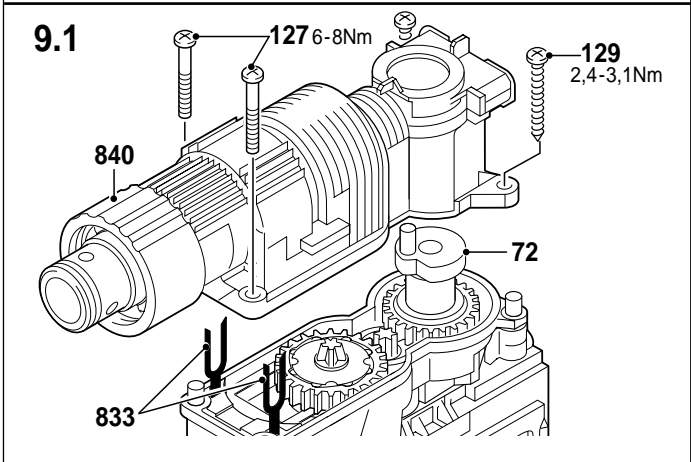
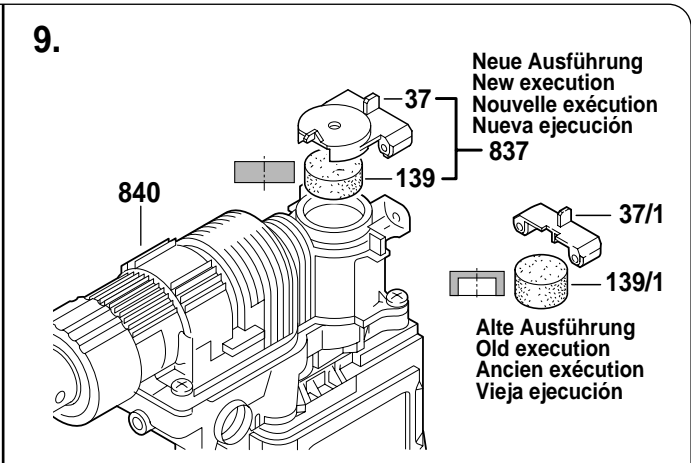
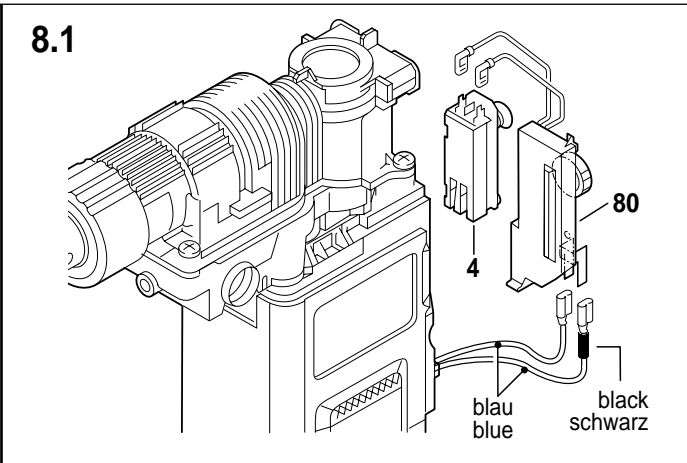
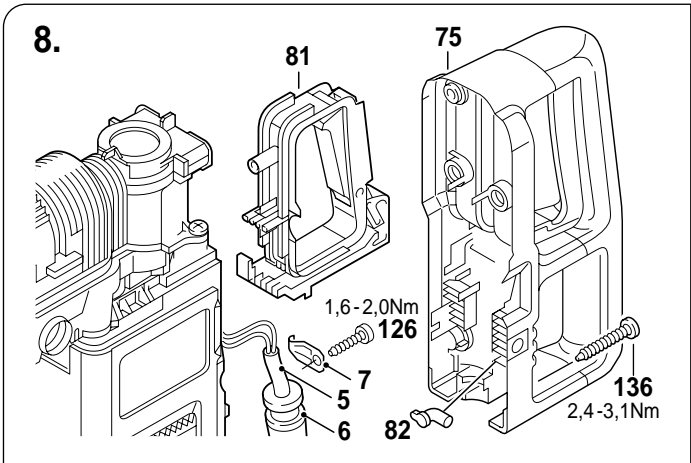

10.1

Alte Ausführung Pos. 45; 123; 74
Old execution
Ancien exécution
Vieja ejecución

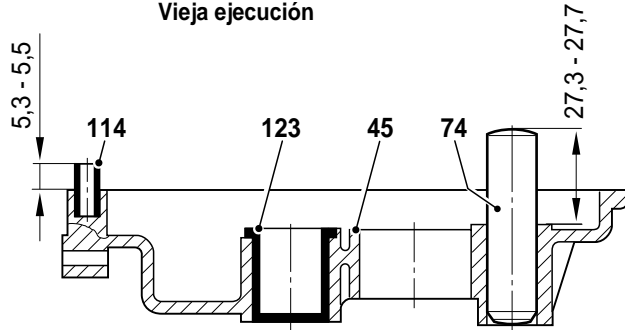

10.2

Alte Ausführung
Old execution
Ancien exécution
Vieja ejecución

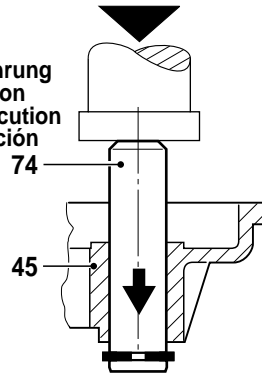

10.3

Alte Ausführung
Old execution
Ancien exécution
Vieja ejecución

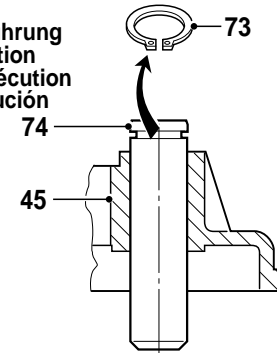

10.4

Alte Ausführung
Old execution
Ancien exécution
Vieja ejecución

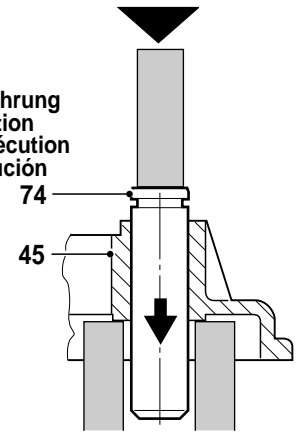

10.5

Neue Ausführung Pos. 45; 123; 142; 74
New execution
Nouvelle exécution
Nueva ejecución

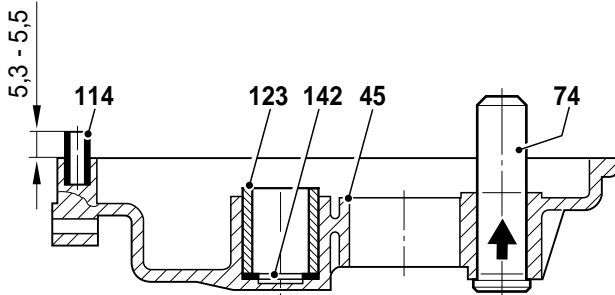

10.6

Neue Ausführung
New execution
Nouvelle exécution
Nueva ejecución

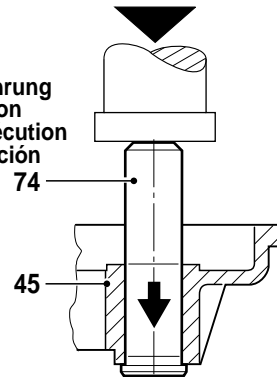

10.7

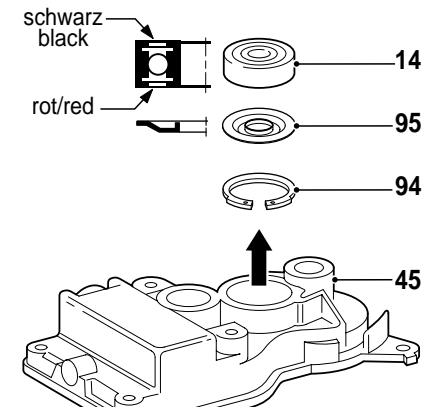

11.

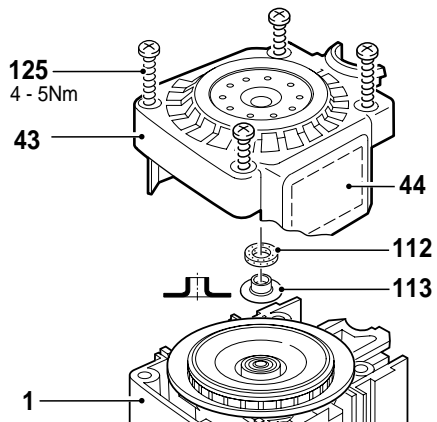

11.1

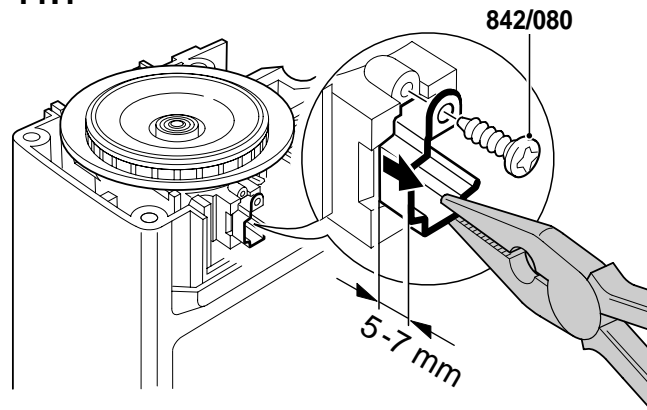

11.2

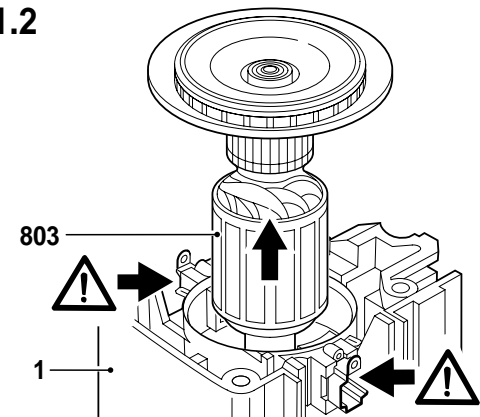

12.

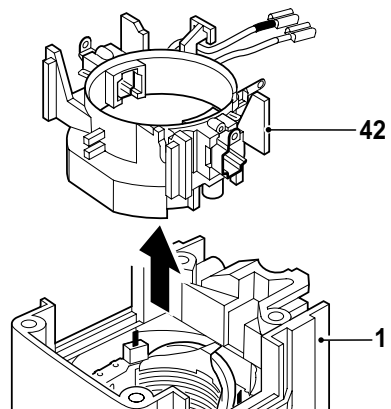

12.1

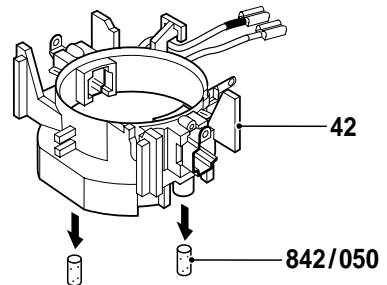

13.

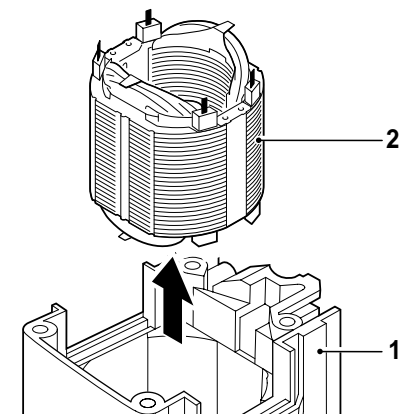

Zusammenbau

Montage nach Explosionszeichnung und diesem Instandsetzungshinweis.

Alle Teile sind gereinigt, abgenutzte und beschädigte Teile werden ersetzt.

Nur Original-Ersatzteile verwenden.

Zähne aller Zahnräder mit Fett **1 615 430 002** bestreichen.

Bitte Schmierhinweise beachten!

Assembly

Assembly using explosion drawings and these repair instructions!

Clean all parts, replace worn-out and damaged parts.

Use only original spare parts!

Grease all gear teeth **1 615 430 002**.

Please note lubrication instructions!

Montage

Le montage s'effectue selon la vue éclatée et les instructions de réparation suivantes.

Toutes les pièces sont nettoyées, les pièces usées ou endommagées doivent être remplacées par des nouvelles. Pour le remplacement de pièces, n'utiliser que des pièces d'origine.

Les dents graisser **1 615 430 002**.

Respecter les instructions de graissage!

Montaje

Realizar el montaje conforme a los dibujos en perspectiva y a estas instrucciones de reparación.

Todas las piezas deben estar limpias. Las piezas desgastadas o dañadas deben reemplazarse por piezas nuevas. Utilizar solamente piezas de repuesto originales.

Dientes engrasar **1 615 430 002**.

Observar las instrucciones de lubricación!

21.

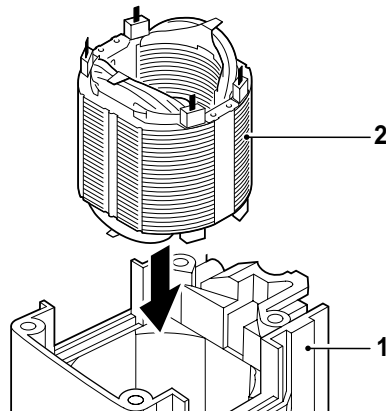

21.1

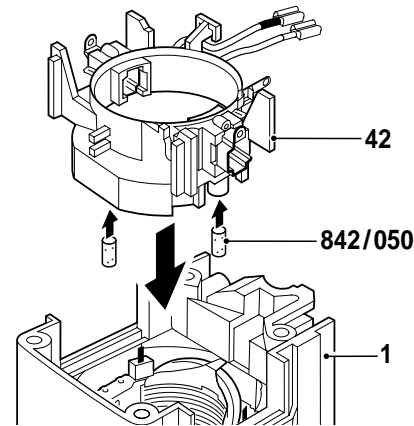

21.2

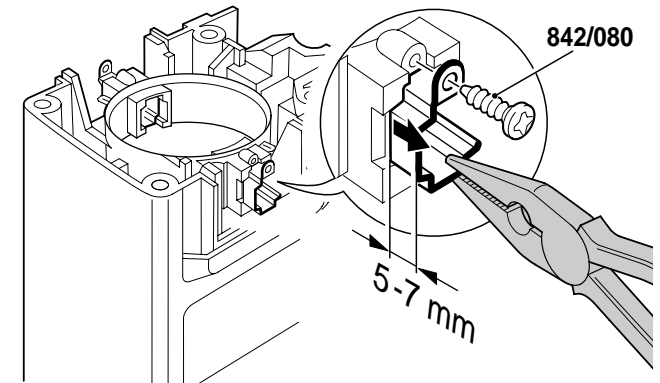

21.3

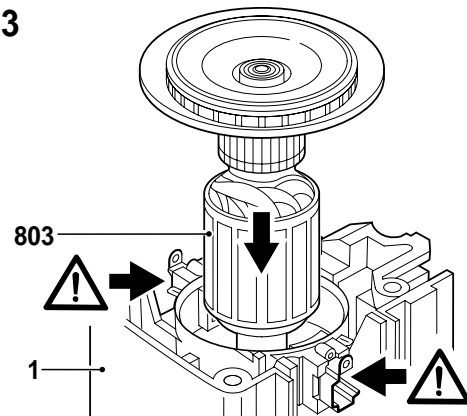

21.4

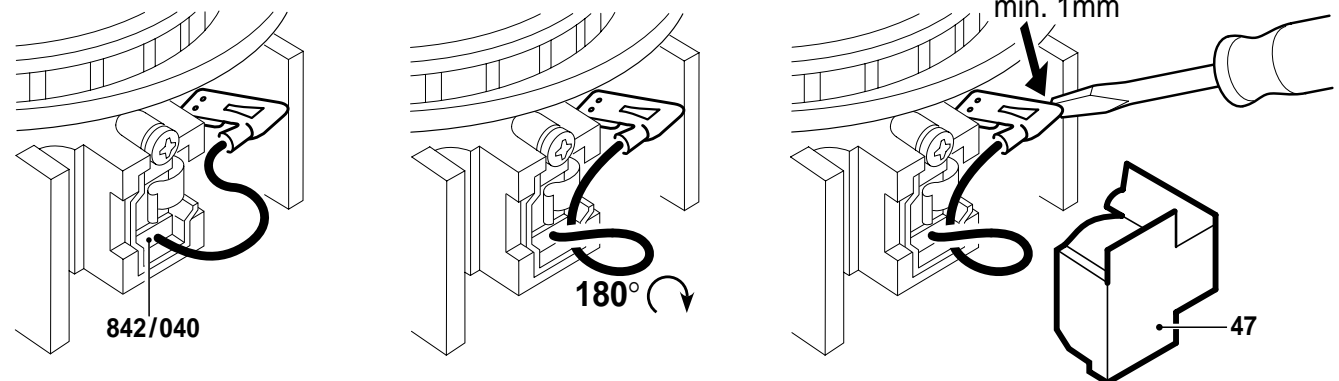

22.

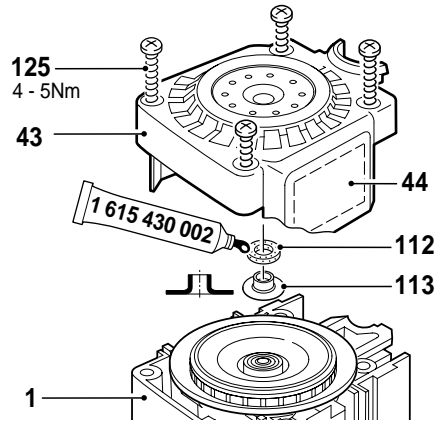

23.

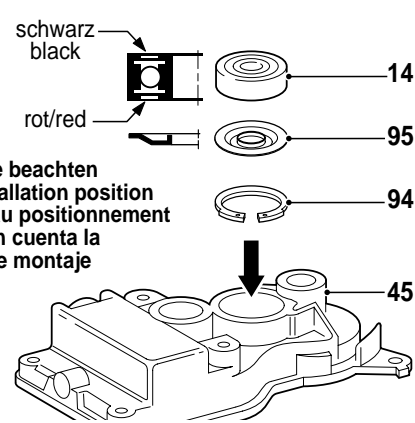

23.1

Alte Ausführung Pos. 45; 123; 74
 Old execution
 Ancien exécution
 Vieja ejecución

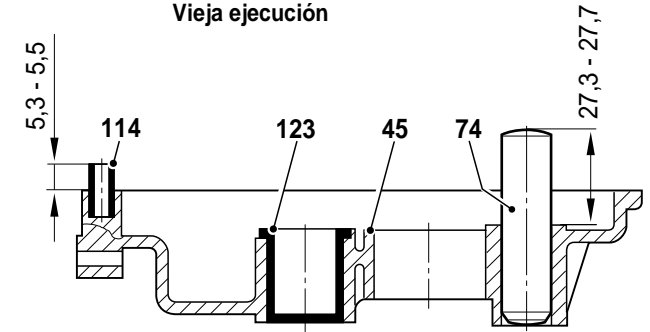

23.2

Alte Ausführung Pos. 74
 Old execution
 Ancien exécution
 Vieja ejecución

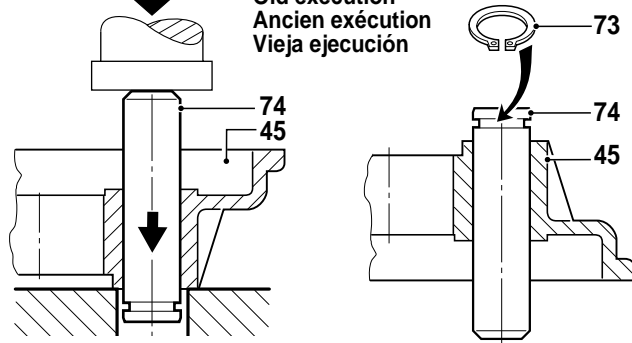

23.3

Alte Ausführung Pos. 74
 Old execution
 Ancien exécution
 Vieja ejecución

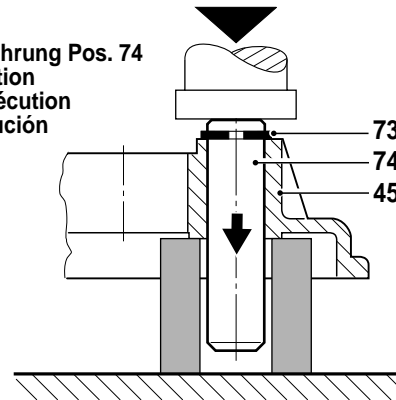

23.4

Neue Ausführung
 New execution
 Nouvelle exécution
 Nueva ejecución

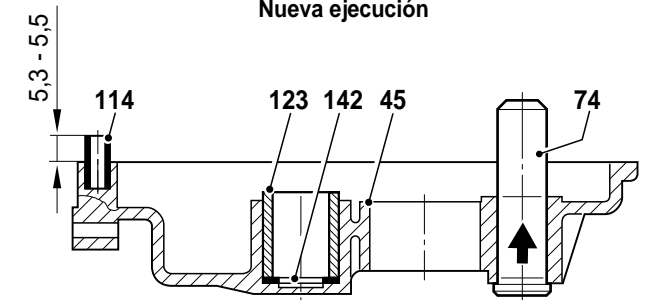

23.5

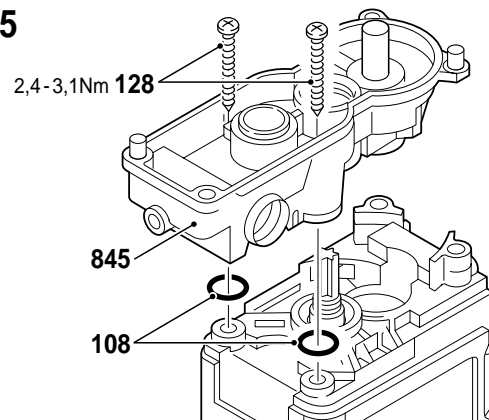

24.

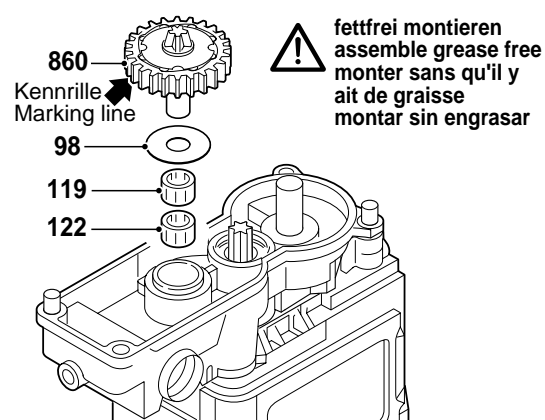

24.1

fettfrei montieren
 assemble grease free
 monter sans qu'il y
 ait de graisse
 montar sin engrasar

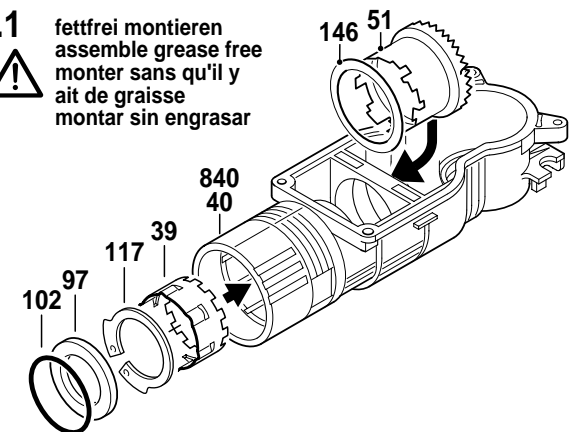

24.2

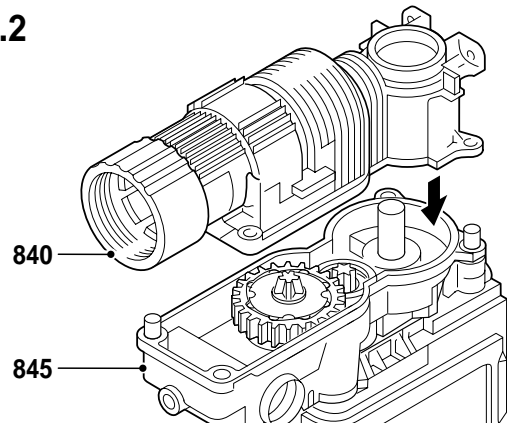

24.3

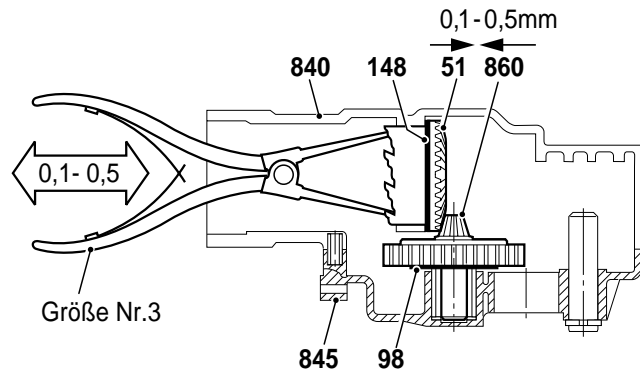

Zahnspiel **fettfrei** messen!
Spiel zwischen Pos.51 und Pos. 860 = 0,1 - 0,5mm.
Ausgleich mit Pos. 148.

Measure gear play **grease free!**
Play between pos. 51 and pos. 860 = 0,1 - 0,5mm.
Compensate with pos. 148.

Mesurer le jeu des dents **sans qu'il y ait de graisse!**
Le jeu entre pos. 51 et pos. 860 = 0,1 - 0,5mm.
Compensation avec pos. 148.

Medir el juego entre dientes **sin haber aplicado grasa!**
El juego entre pos. 51 y pos. 860 = 0,1 - 0,5mm.
El reglaje se realiza con pos. 148.

24.4

Nach der Spielmessung bitte die Teile fetten!
After measuring gear play, please grease the parts!
Après avoir mesuré le jeu, graisser les pièces, s.v.p.!
Después de la medición del juego deben lubricarse las piezas!

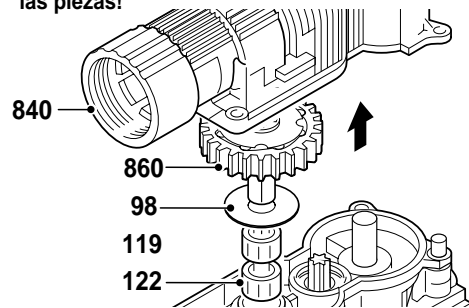

25.

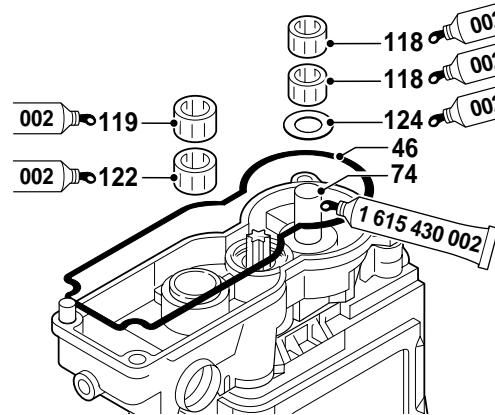

25.1

Pos. 19, 20, 35, 41, 51, 57, 70, 124 fetten (25 -30g);
Rest in Getrieberaum Pos. 845.
Grease the parts pos. 19, 20, 35, 41, 51, 57, 70, 124 (25 -30g);
rest into gear compartment pos. 845.
Graisser les pieces pos. 19, 20, 35, 41, 51, 57, 70, 124 (25 -30g);
la graisse restante dans le compartiment d'engrenage pos. 845.
Engrasar las piezas pos. 19, 20, 35, 41, 51, 57, 70, 124 (25 -30g);
resto en el compartimento del engranaje pos. 845.

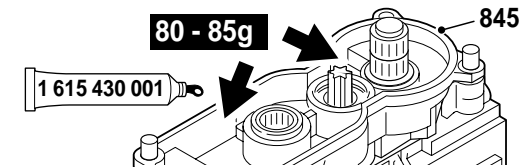

25.2

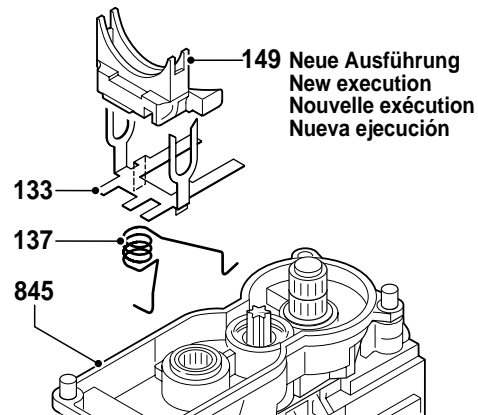

25.3

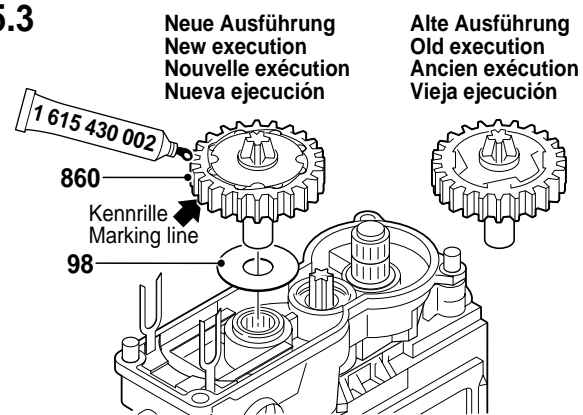

26.

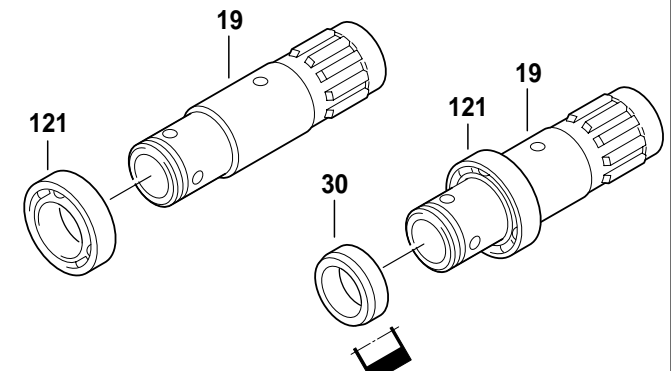

26.1

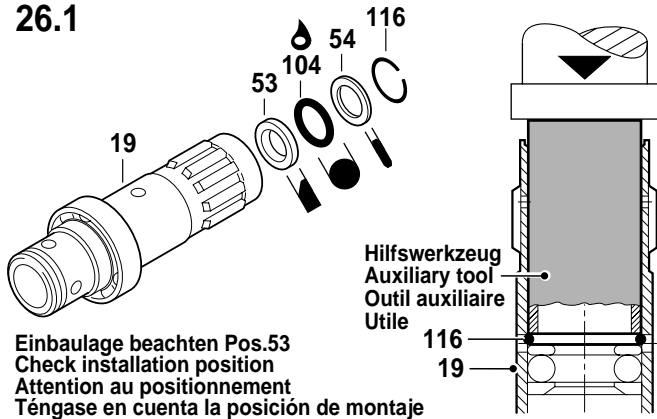

Einbauage beachten Pos.53
Check installation position
Attention au positionnement
Téngase en cuenta la posición de montaje

Hilfswerkzeug
Auxiliary tool
Outil auxiliaire
Utile

26.2

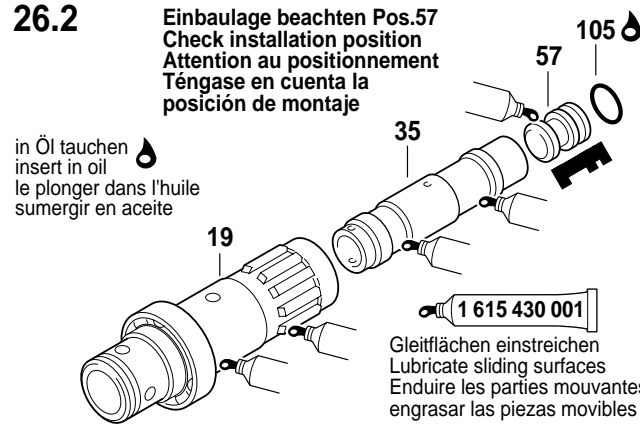

in Öl tauchen
insert in oil
le plonger dans l'huile
sumergir en aceite

Einbauage beachten Pos.57
Check installation position
Attention au positionnement
Téngase en cuenta la posición de montaje

1 615 430 001
Gleitflächen einstreichen
Lubricate sliding surfaces
Enduire les parties mouvantes
engrasar las piezas móviles

27.

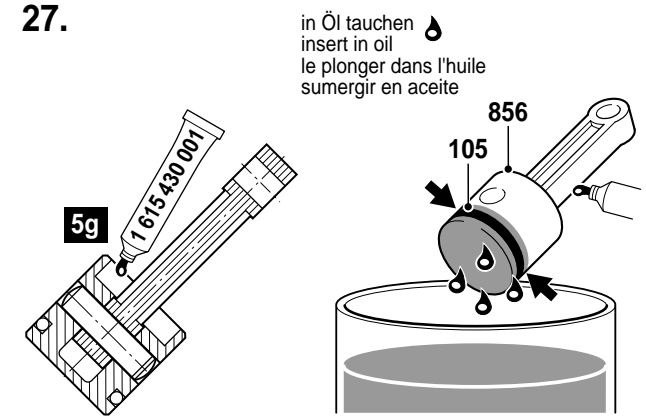

in Öl tauchen
insert in oil
le plonger dans l'huile
sumergir en aceite

27.1

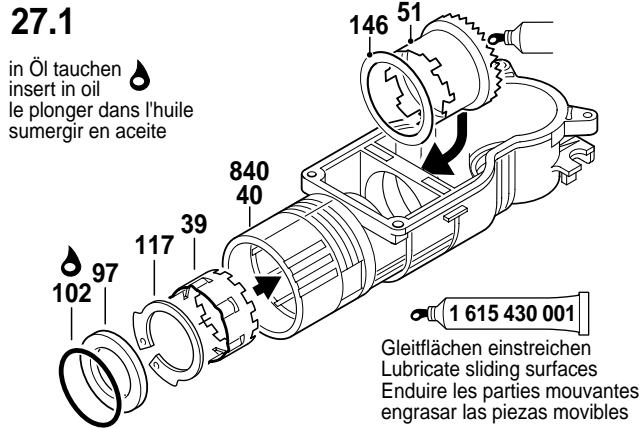

in Öl tauchen
insert in oil
le plonger dans l'huile
sumergir en aceite

1 615 430 001
Gleitflächen einstreichen
Lubricate sliding surfaces
Enduire les parties mouvantes
engrasar las piezas móviles

27.2

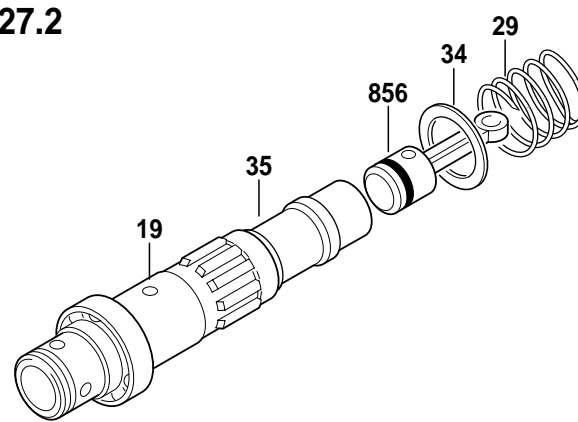

28.

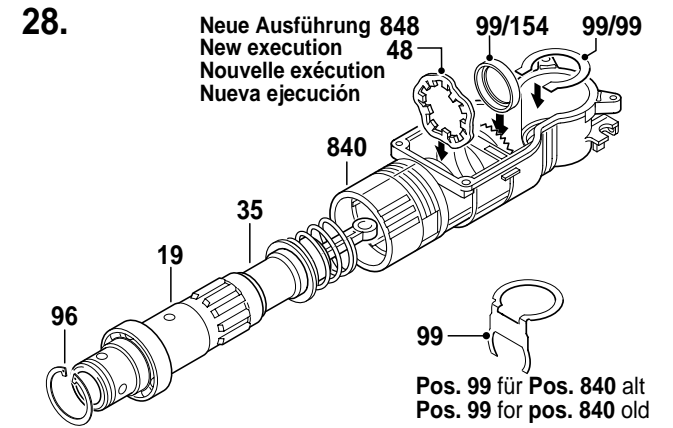

Neue Ausführung 848
New execution 48
Nouvelle exécution
Nueva ejecución

Pos. 99 für Pos. 840 alt
Pos. 99 for pos. 840 old

28.1

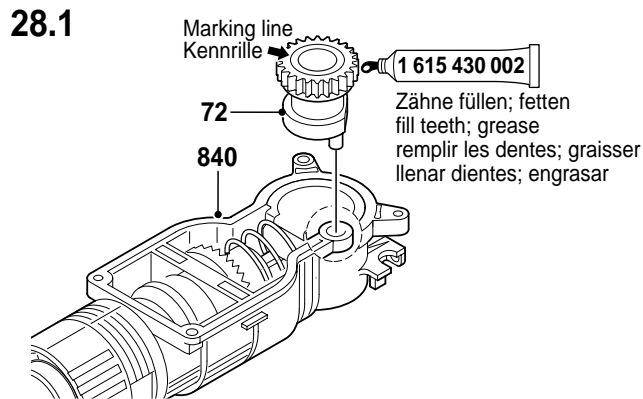

Marking line
Kennrille

1 615 430 002
Zähne füllen; fetten
fill teeth; grease
remplir les dents; graisser
llenar dientes; engrasar

28.2

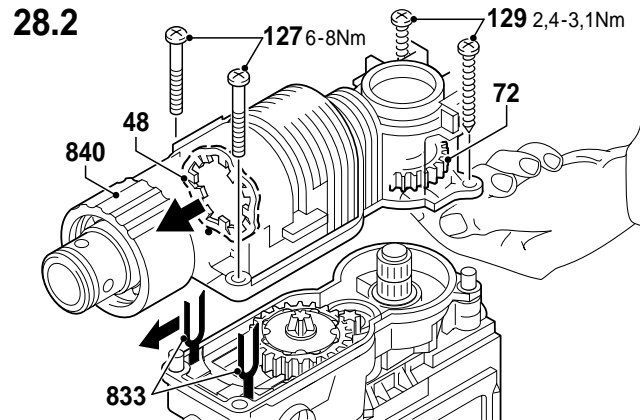

28.3

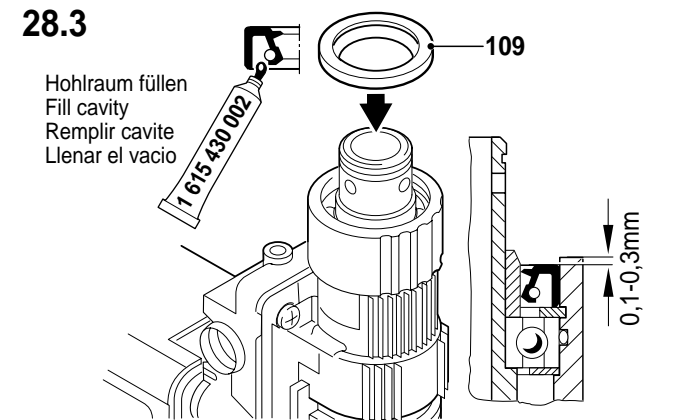

Hohlraum füllen
Fill cavity
Remplir cavité
Llenar el vacío

0,1-0,3mm

28.4

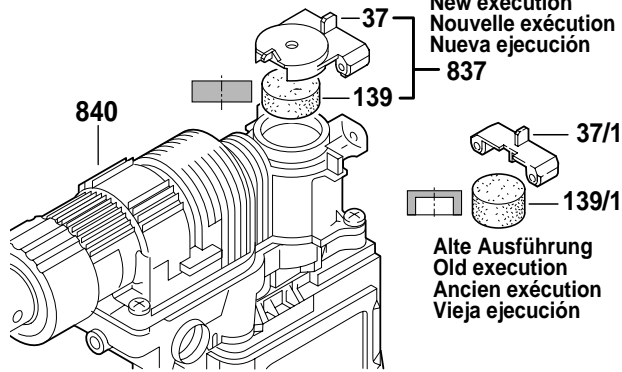

29.

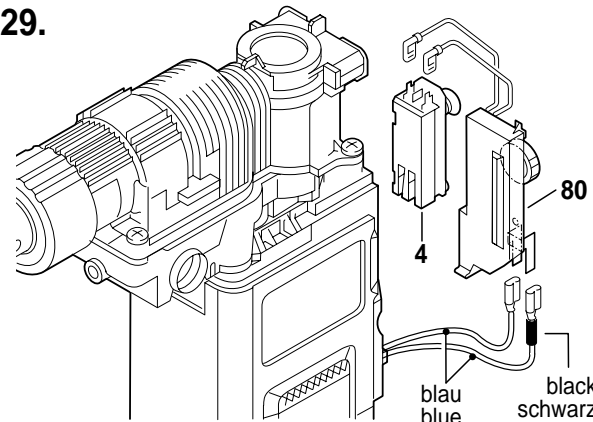

29.1

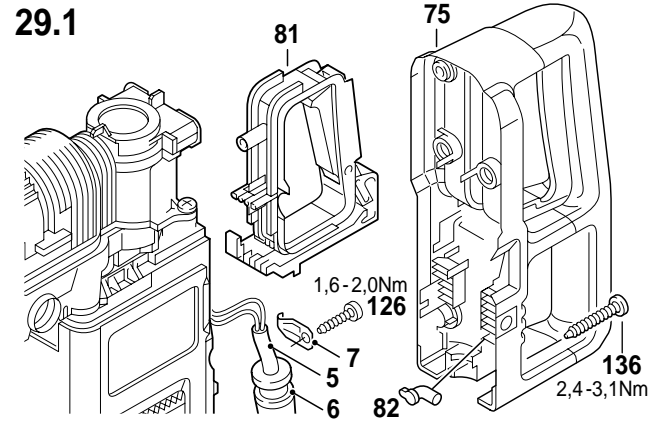

30.

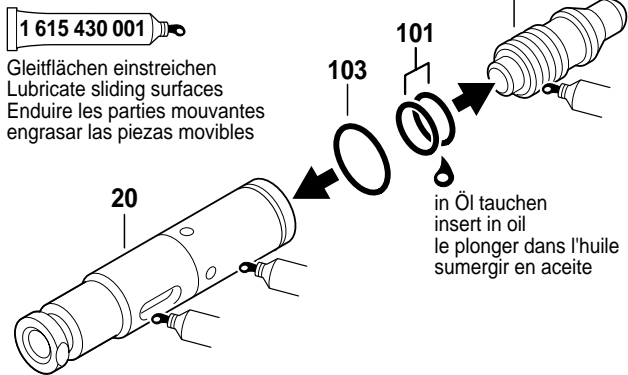

30.1

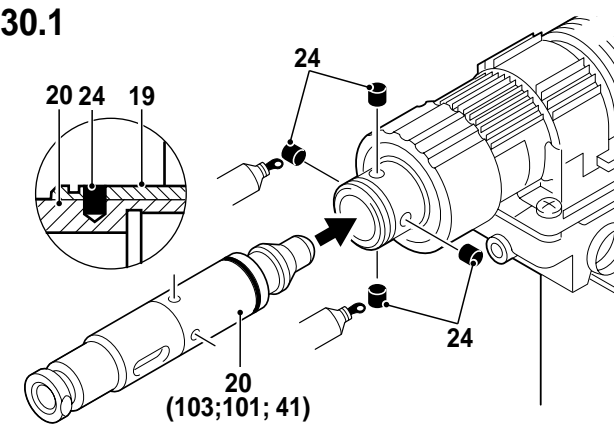

30.2

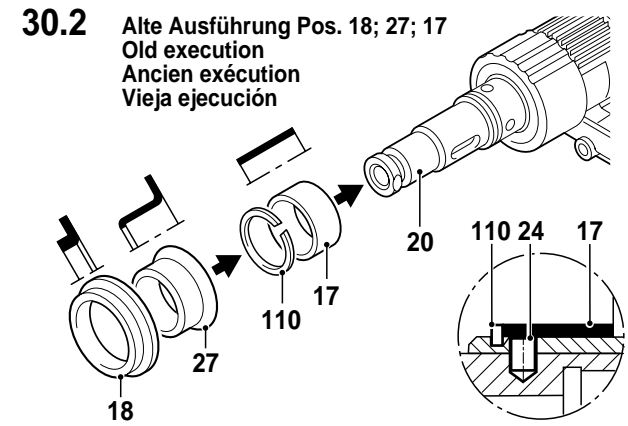

30.3

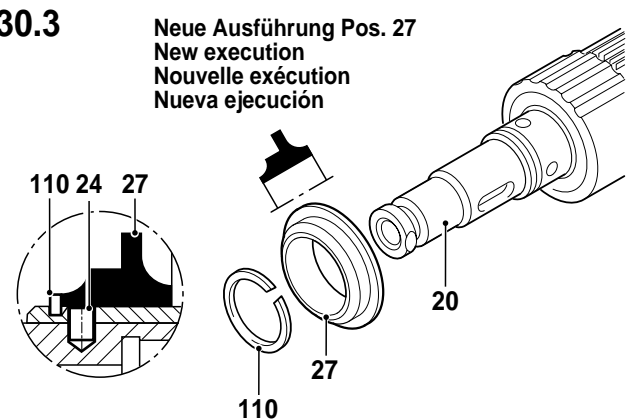

31.

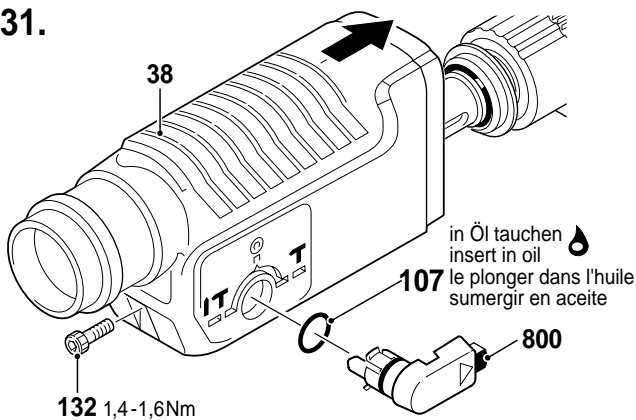

32.

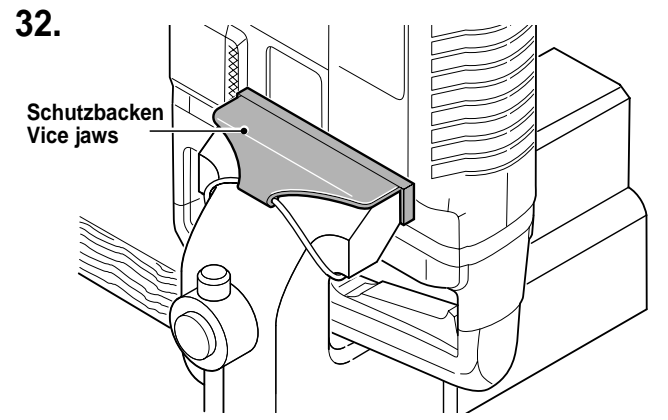

33.

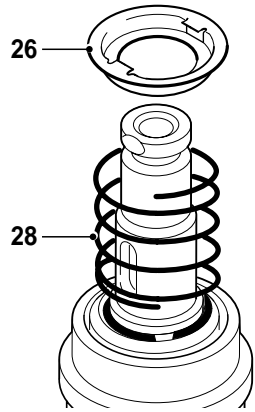

33.1

Nase fetten / grease nose
 graisser nez / engrasar nesar

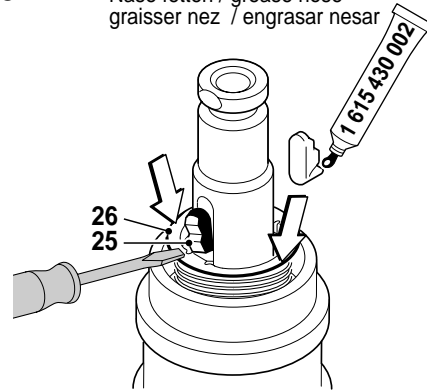

33.2

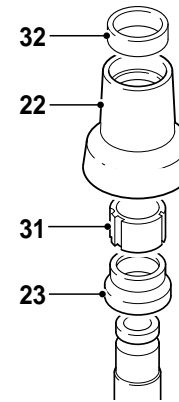

33.3

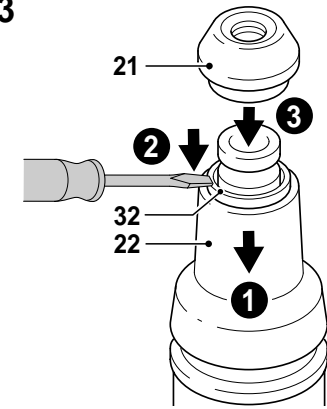

34.

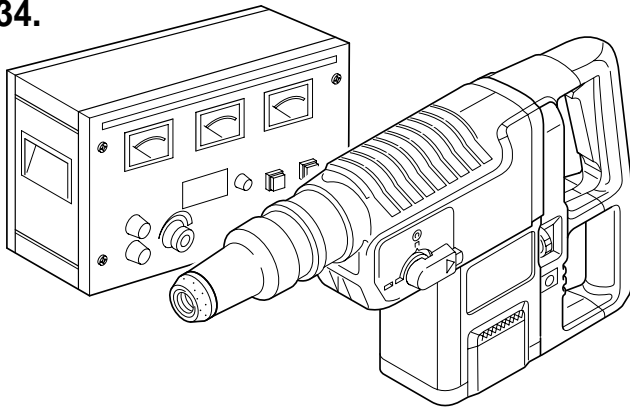

34. Hochspannungsprüfung durchführen.
Beachten:
 Die Sicherheitsvorschriften nach DIN, VDE, CEE, AFNOR und weitere in den einzelnen Ländern gültigen Vorschriften sind einzuhalten.

34. Effectuer un contrôle à haute tension.
Attention:
 Respecter les instructions de sécurité selon DIN, VDE, CEE, AFNOR et les autres instructions valables dans les pays respectifs.

34. Carry out power supply check.
Attention:
 Safety regulations according to DIN, VDE, CEE, AFNOR and further regulations applicable in individual countries must be observed.

34. Efectuar la prueba de alta tensión.
Atención:
 Atenerse a las prescripciones de seguridad según DIN, VDE, CEE, AFNOR y a las prescripciones adicionales específicas que pudieran existir en los respectivos países.

35.

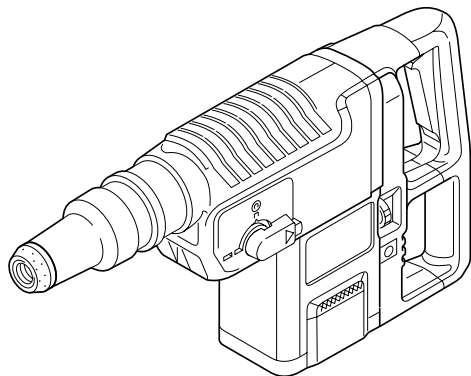

35. Probelauf, Schlagtest, elektrische und mechanische Prüfung durchführen.

35. Marche à titre d'essai, contrôle de frappe et depercage, effectuer un contrôle mécanique et électrique.

35. Perform test run, impact test, electrical and mechanical check-up.

35. Realizar un control funcional, una prueba de taladrado con y sin percusión y los ensayos eléctricos y mecánicos correspondientes.

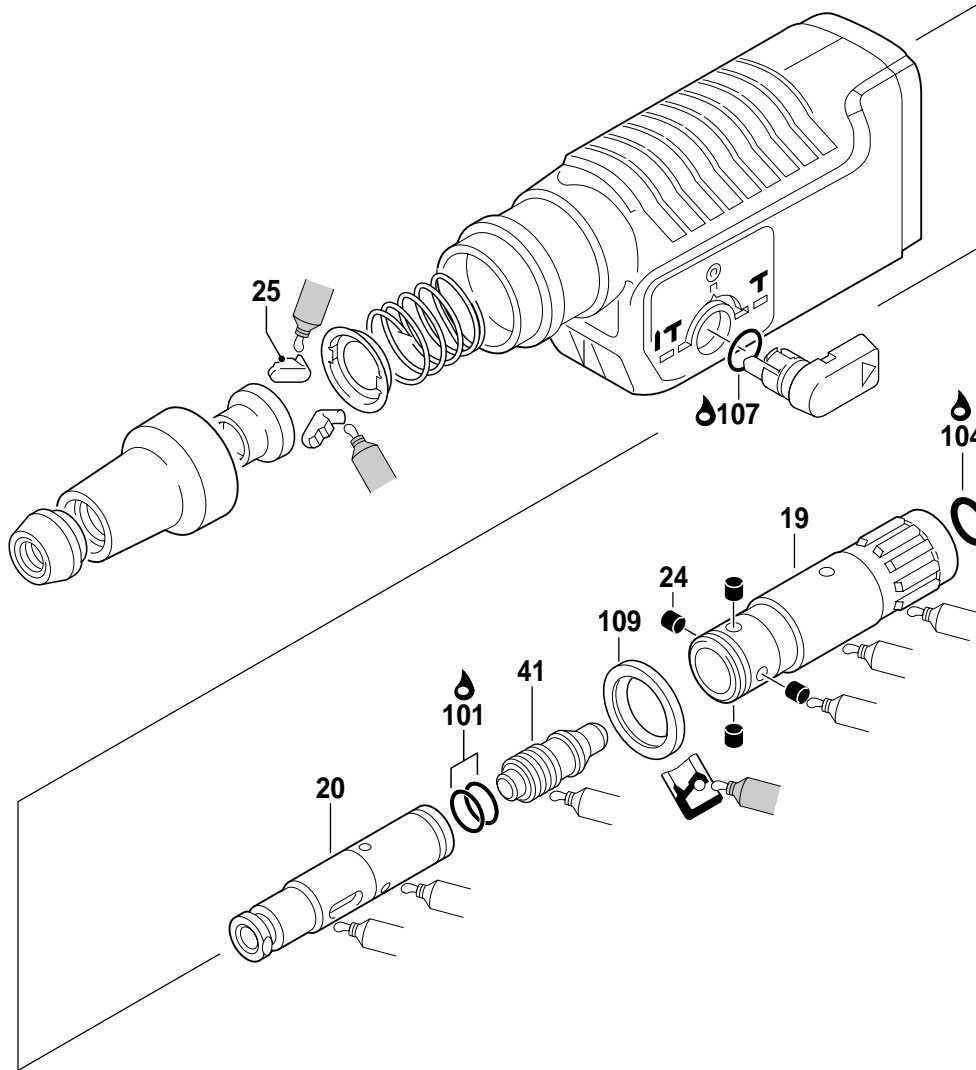

Änderungen vorbehalten
 Modifications reserved
 Modifications réservées
 Salvo modificaciones

 in Öl tauchen
 insert in oil
 le plonger dans l'huile
 sumergir en aceite
SAE 20W

fetten / graisses
 grease / engrasar
1 615 430 001

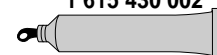
fetten / graisses
 grease / engrasar
1 615 430 002

fetten / graisses
 grease / engrasar
3 605 430 001

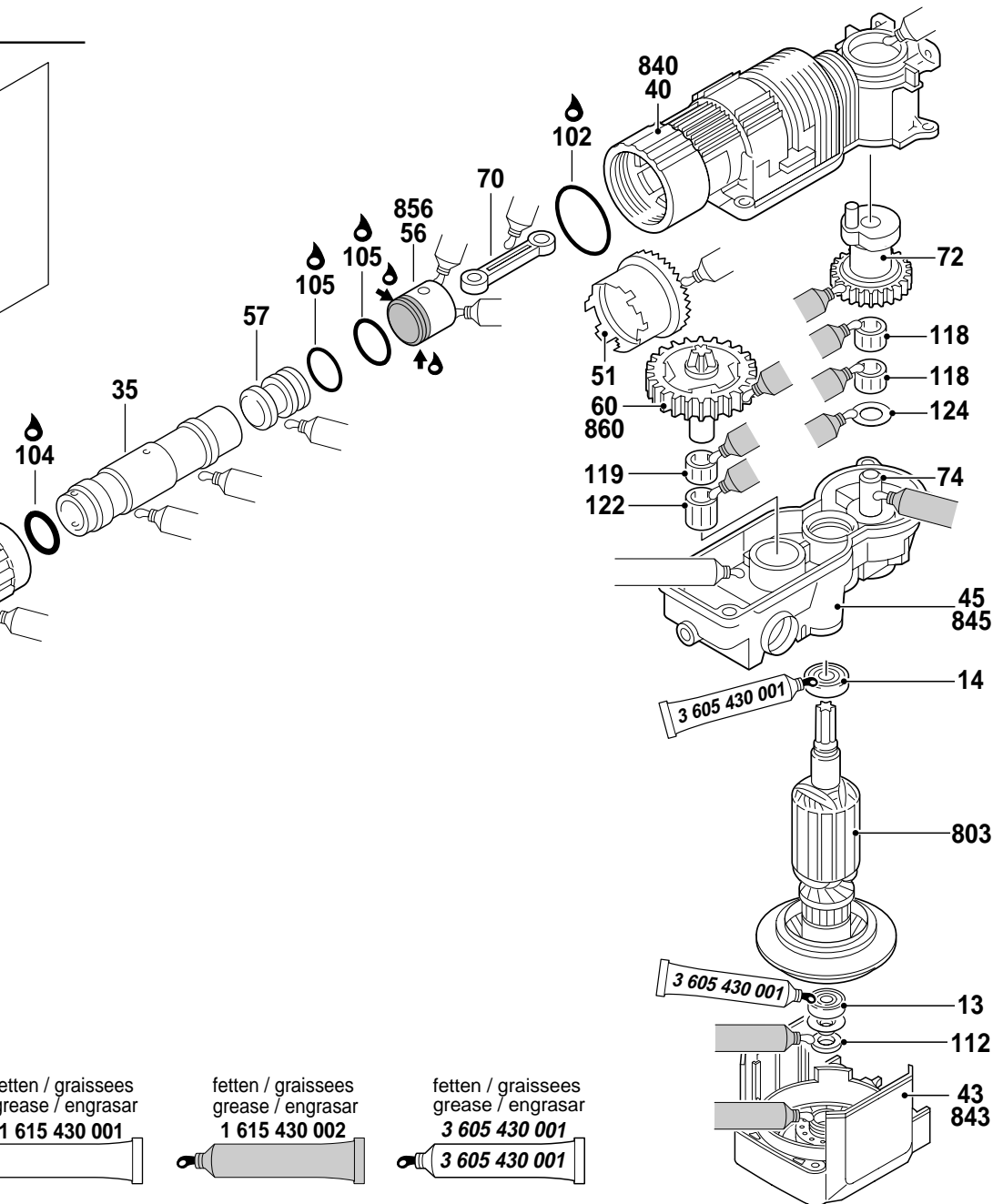
3 605 430 001

3 605 430 001

**Schmierung
Lubrication
Lubrification
Lubrificación**

0 611 216 7 .. = GBH 5/40 DCE

Stand / Issue: 99-07

Änderungen vorbehalten
Modifications reserved
Modifications réservées
Salvo modificaciones

Schmierstelle Lubrication point Point de lubrification Punto de lubricacion	Fig. Pos.	Schmierstoff Fett Öl Lubricant grease oil Lubrifiant graisse huile Lubricante grasa aceite	Mengen Quantity Quantite	Schmiervorschrift Lubricating instructions Indications de graissage Instrucciones de lubricacion
Getriebe und Schlagwerkraum Gear and percussion mechanism space Carter de l'engrenage et boîtier du système de frappe Engranaje y parte de engranaje	840 (40) 845 (45) 19; 20 35 41 51; 57 70 124	1 615 430 001	80-85 g	Teile fetten, Rest in Getrieberraum grease the parts, rest into gear compartment graisser les pieces, la graisse restante dans le compartiment d'engrenage engrasar las piezas, resto en el compartimento del engranaje
Hammerkolben Hammer piston Piston de marteau Embolo del martillo	856 (56)		5 g	Hohlraum füllen fill cavity remplir cavite llenar el vacio
Exzenterzahnrad Eccentric cog wheel Roue dentee a excentrique Rueda dentada excentrica	72	1 615 430 002	4 g 1 g	Zähne fetten; grease teeth dents graissees; engrasar los dientes Bolzen fetten; grease pin boulon graissees; engrasar los perno
Stirnradkupplung Spur wheel clutch Embrayage Embrag rendas dent recta	860 (60)		3 g	Zähne füllen; fetten fill teeth; grease remplir les dents; graisser llenar dientes; engrasar
Wellendichtring Shaft sealing ring Joint a levres Reten para arboles	109			Hohlraum zwischen Dichtlippen füllen fill cavity between sealing lips remplir cavite entre les levres du joint llenar el vacio entre los labios del reten
Sperrkörper Stopping device Corps d'arret Cuerpo de bloqueo	25			Nase fetten grease nose graisser neez engrasar nesar
Nadellager Needle-roller bearing Roulement d'aiguilles Rodamiento de agujas casquillo	118 119 122		*	fetten grease graisser engrasar
Teile Parts Pieces Piezas	843 (43) 74 112			fetten grease graisser engrasar

* sofern Lager ungefettet
if bearing is unlubricated
si roulement n'est pas graisse
en caso de que el rodamiento esta son grasa

Schmierstelle Lubrication point Point de lubrification Punto de lubricacion	Fig. Pos.	Schmierstoff Fett Öl Lubricant grease oil Lubrifiant graisse huile Lubricante grasa aceite	Mengen Quantity Quantite	Schmierstoffvorschrift Lubricating instructions Indications de graissage Instrucciones de lubricacion
Rillenkugellager Deep-groove ball bearing Roulement a billes rigide Rodamiento radial rigido	13 14	3 605 430 001	*	2/3 füllen fill remplir llenar
Hammerkolben Hammer piston Piston de marteau Embolo del martillo	856 (56)	SAE 20 W Mineralöl, handelsüblich Mineral oil, standard Huile minérale en vente dans le comerc Aceite mineral usual en el comercio		in Öl tauchen insert in oil le plonger dans l'huile sumergir en aceite
O-Ring O-ring Bague O Anillo toeodial	101;102 104 105 107			in Öl tauchen insert in oil le plonger dans l'huile sumergir en aceite

* sofern Lager ungefettet
if bearing is unlubricated
si roulement n'est pas graisse
en caso de que el rodamiento esta son grasa

Prüfwerte
Testing values
Valeurs de vérification
Valores de control

0 611 216 7 .. = GBH 5/40 DCE

Stand / Issue: 99-07

Spannung Voltage Voltage Voltaje	Leerlauf no-load running marche à vide marcha en vacío		Widerstand (20°C/ 68°F) resistance résistance resistencia		Zulässige Übertemperatur im Leerlauf admissible over temperature at no-load élévation admissible de température à vide sobretemperatura admisible en vacío		
V Typ	A	Spindeldrehzahl speed of spindle vitesse de la broche velocidad del husillo 1/min - rpm - t/mn - rpm Stufe	des Ankers of rotor du rotor del rotor Ω	einer Feldspule of one stator coil d'une bobine du stator de una bobina del estator Ω	Motor motor moteur motor °C	Getriebe gear engrenage engrenaje °C	Arbeitsspindel spindle broche husillo °C
100	6.125 - 8.875	1 171 - 210 6 332 - 388	0.438 - 0.593	0.290 - 0.400	6	3	10
110	7.000 - 9.000	1 171 - 210 6 332 - 388	0.438 - 0.593	0.290 - 0.400	6	3	10
115	4.920 - 6.280	1 171 - 210 6 332 - 388	0.682 - 0.869	0.406 - 0.544	6	3	10
220	2.640 - 3.760	1 171 - 210 6 332 - 388	2.205 - 2.805	1.600 - 2.010	6	3	10
230	2.640 - 3.760	1 171 - 210 6 332 - 388	2.205 - 2.805	1.600 - 2.010	6	3	10
240	2.640 - 3.760	1 171 - 210 6 332 - 388	2.205 - 2.805	1.600 - 2.010	6	3	10

Bemerkung: Überrasstmoment der Kupplung 16 -20 Nm. Bei nicht erreichen von 16 Nm, Kupplung ersetzen.
 For your notice: Slipping point of clutch 16 - 20 Nm. Under 16 Nm replace clutch.

Kollektor-Mindestdurchmesser: Minimum diameter of commutator: Diamètre minimum du collecteur: Diámetro mínimo del colector:	mm	Kohlebürsten-Mindestlänge: Minimum length of brushes: Longueur minimale des balais: Longitud mínima de las escobillas:	= X	Abschaltkohlen cut-off brushes charbon rupteur carbón de desconexión
--	----	---	-----	---

Änderungen vorbehalten

Unsere Erzeugnisse werden stets dem neuesten technischen Stand angepaßt. Deshalb müssen wir uns Änderungen von technischen Daten vorbehalten.

Modifications

Our products are constantly modified to meet new technical standards. We there-fore reserve the right to alter data and specifications without prior notice.

Modifications

Nos produits sont continuellement adaptés aux dernières nouveautés techniques et les dates sont données sous réserve de changement.

Modificaciones

Nuestros fabricados van siendo adaptados constantemente a las últimas conquistas técnicas. Por ello, tenemos que reservarnos el derecho de introducir modificaciones en los datos técnicos.