

**INSTANDSETZUNGSHINWEISE**  
**REPAIR INSTRUCTIONS**  
**INSTRUCTIONS DE REPARATION**  
**INSTRUCCIONES DE REPARACION**



**Schlaghammer**  
**Demolition hammer**  
**Marteau piqueur**  
**Martillo de percusion**

**Typ 0 611 316 7. . = GSH 11 E**

Änderungen vorbehalten. Unsere Erzeugnisse werden stets dem neuesten technischen Stand angepaßt. Deshalb behalten wir uns Änderungen vor.

Modifications. Our products are constantly modified to meet new technical standards. We therefore reserve the right to alter data and specifications without prior notice.

Modifications. Nos produits sont continuellement adaptés aux dernières nouveautés techniques et les dates sont données sous réserve de changement.

Modificaciones. Nuestros fabricados van siendo adaptos constantemente a las últimas conquistas técnicas. Por ello, tenemos que reservarnos el derecho de introducir modificaciones en los datos técnicos.

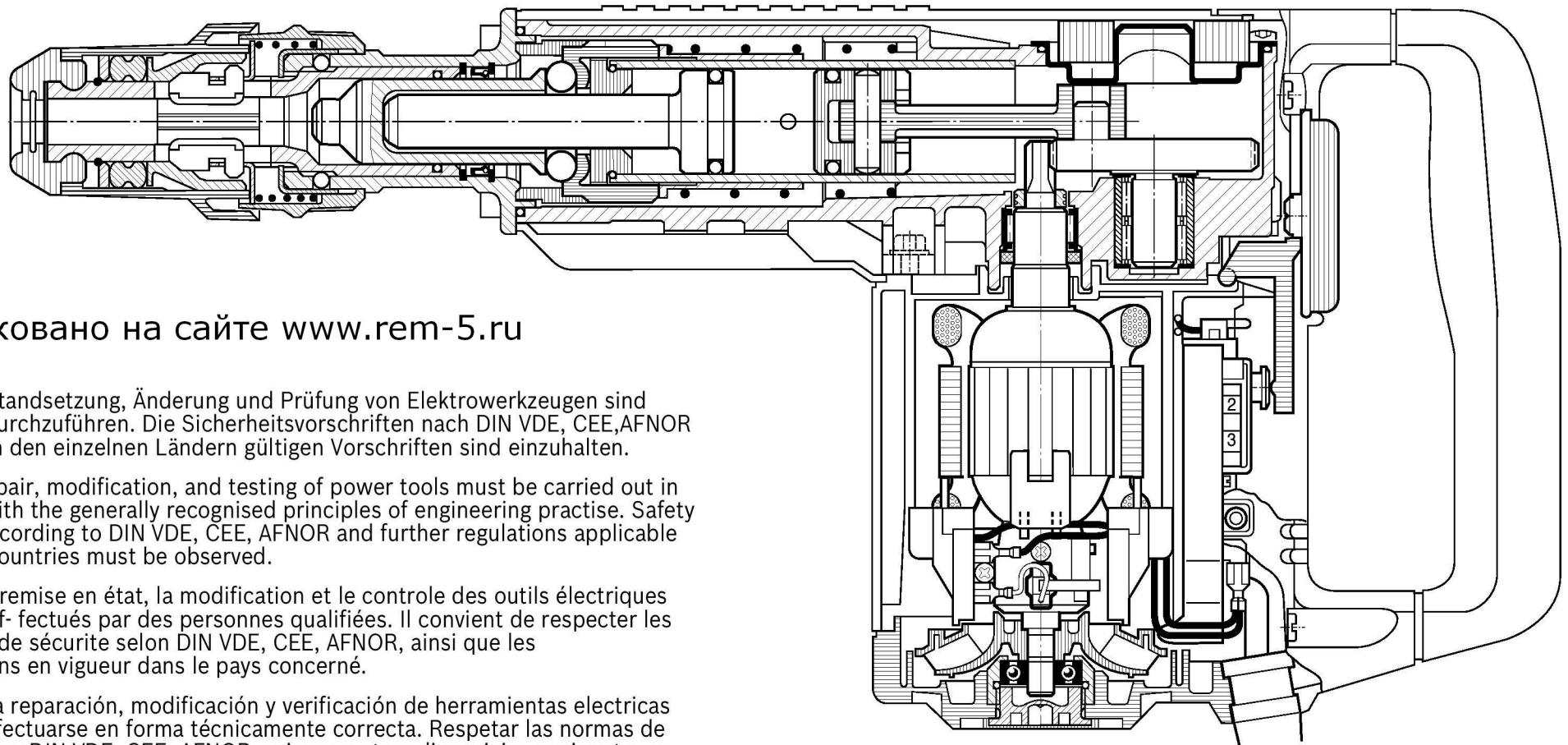

Опубликовано на сайте [www.rem-5.ru](http://www.rem-5.ru)

**Beachten:** Instandsetzung, Änderung und Prüfung von Elektrowerkzeugen sind fachgerecht durchzuführen. Die Sicherheitsvorschriften nach DIN VDE, CEE, AFNOR und weitere in den einzelnen Ländern gültigen Vorschriften sind einzuhalten.

**Attention:** Repair, modification, and testing of power tools must be carried out in accordance with the generally recognised principles of engineering practise. Safety regulations according to DIN VDE, CEE, AFNOR and further regulations applicable in individual countries must be observed.

**Attention:** La remise en état, la modification et le controle des outils électriques doivent être effectués par des personnes qualifiées. Il convient de respecter les prescriptions de sécurité selon DIN VDE, CEE, AFNOR, ainsi que les réglementations en vigueur dans le pays concerné.

**Obsérvese:** La reparación, modificación y verificación de herramientas electricas mano debe efectuarse en forma técnicamente correcta. Respetar las normas de seguridad segun DIN VDE, CEE, AFNOR, asi como otras disposiciones vigentes en los distinos paises.

## Zerlegen

Für die Demontage werden handelsübliche Werkzeuge benötigt.

1. Eingangsprüfung durchführen.  
**Beachten:**  
Die Sicherheitsvorschriften nach DIN, VDE, CEE, AFNOR und weitere in den einzelnen Ländern gültigen Vorschriften sind einzuhalten.

## Disassembly

Use normal trade tools by disassembly.

1. Carry out power supply check.  
**Attention:**  
Safety regulations according to DIN, VDE, CEE, AFNOR and further regulations applicable in individual countries must be observed.

## Démontage

Pour le démontage, des outils en usage dans le commerce sont nécessaires.

1. Effectuer un contrôle préliminaire.  
**Attention:**  
Respecter les instructions de sécurité selon DIN, VDE, CEE, AFNOR et les autres instructions valables dans les pays respectifs.

## Desmontaje

Para el desmontaje no se precisan herramientas especiales.

1. Realizar control de recepción.  
**Atención:**  
Atenerse a las prescripciones de seguridad según DIN, VDE, CEE, AFNOR y a las prescripciones adicionales específicas que pudieran existir en los respectivos países.

1.

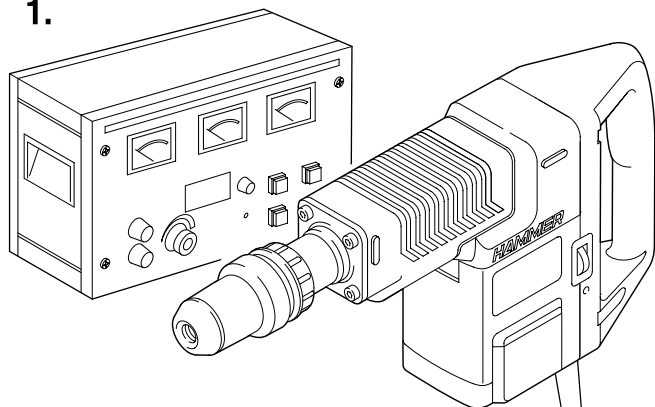

2.

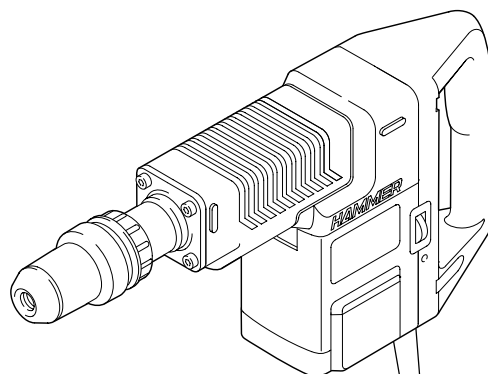

2. Zerlegen nach Explosions-, Schnittzeichnung und diesem Instandsetzungshinweis.
2. Disassembly using explosion, cut-away drawings and these repair instructions!
2. Démontez l'appareil suivant la vue éclatée, le plan en coupe et ces instructions de réparation.
2. Realizar el desmontaje conforme a los dibujos en perspectiva y en sección, y a estas instrucciones de reparación.

3.

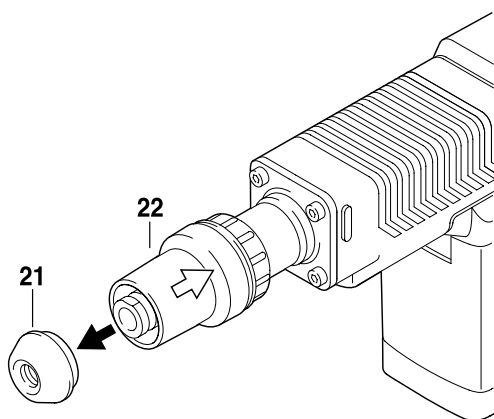

3.1

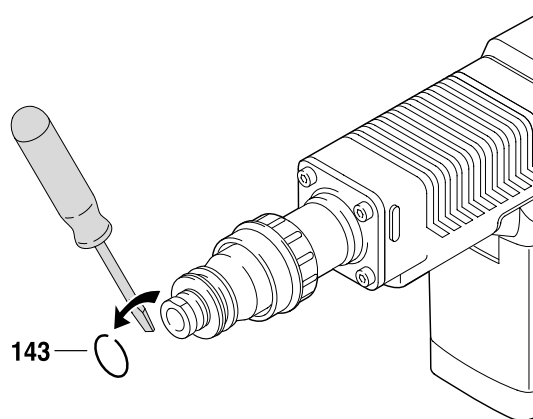

3.2

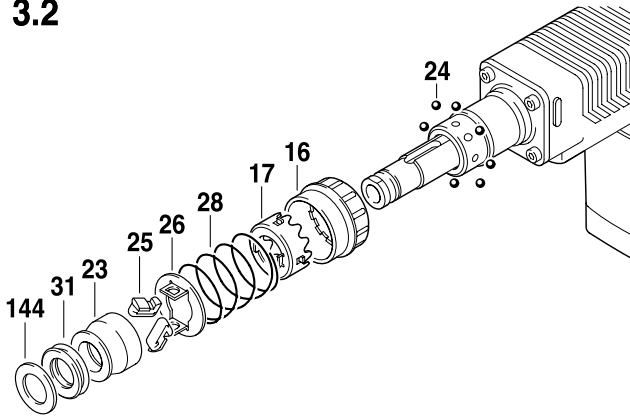

3.3

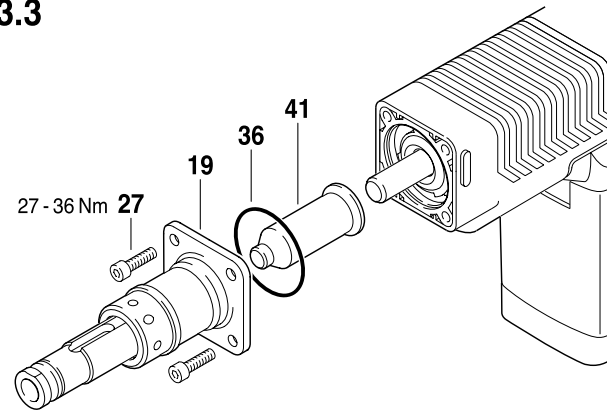

3.4

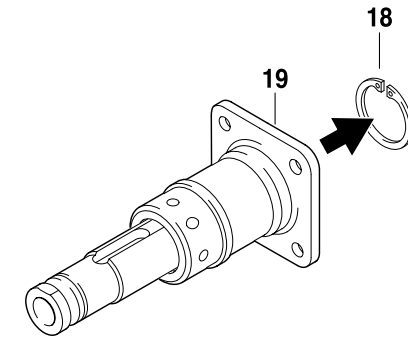

3.5

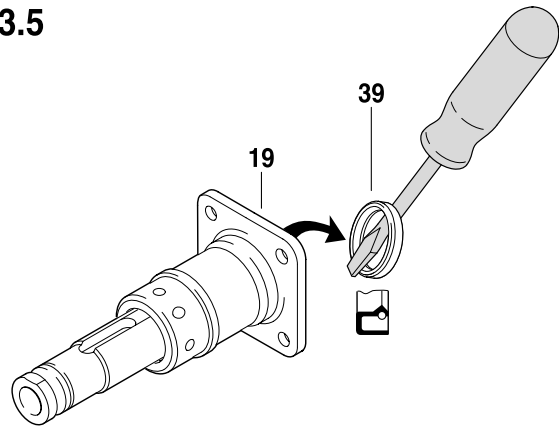

3.6

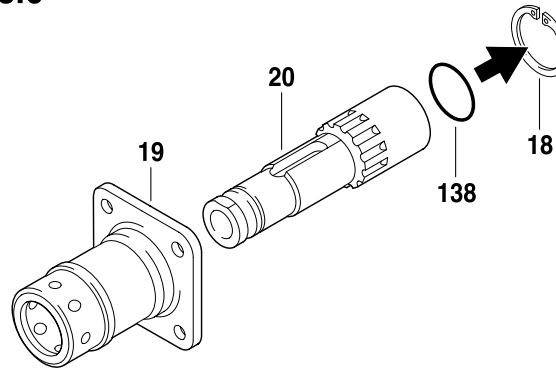

4.

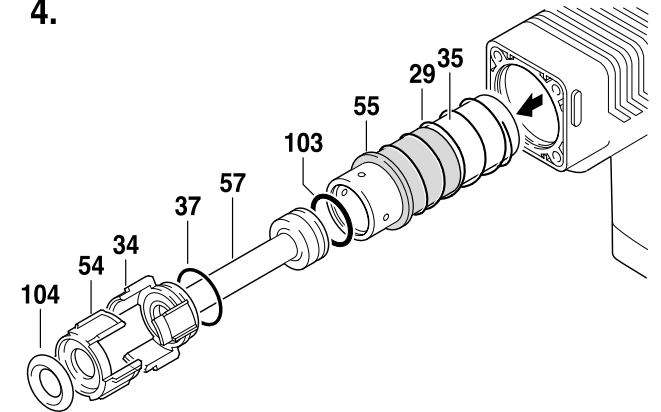

5.

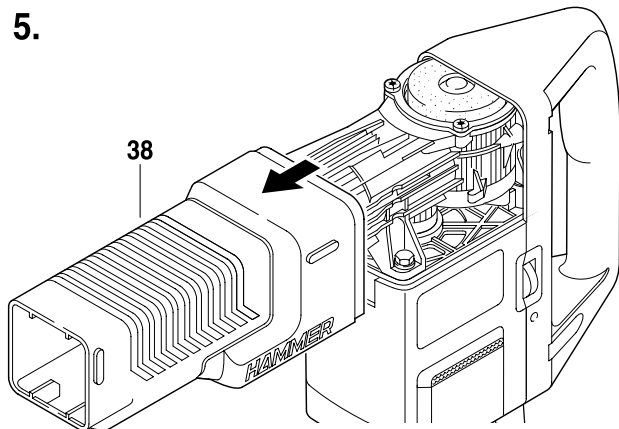

5.1

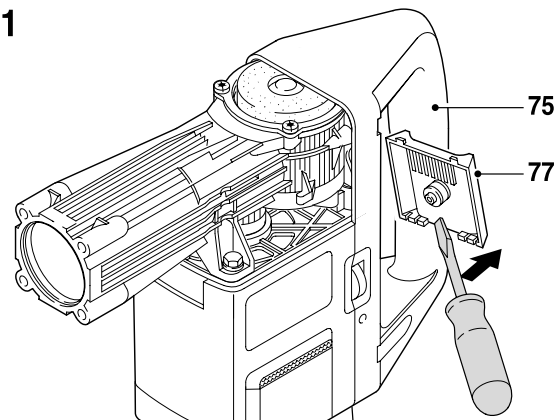

5.2

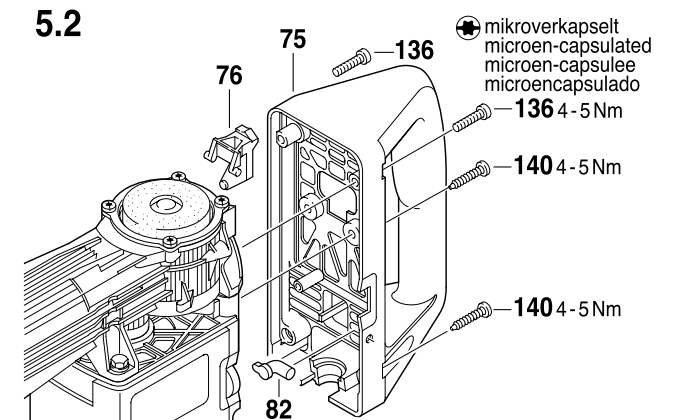

6.

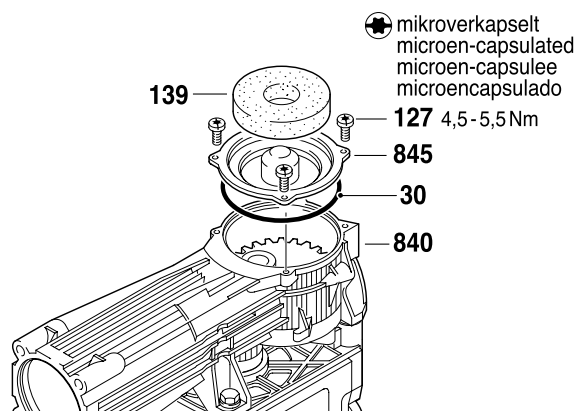

6.1

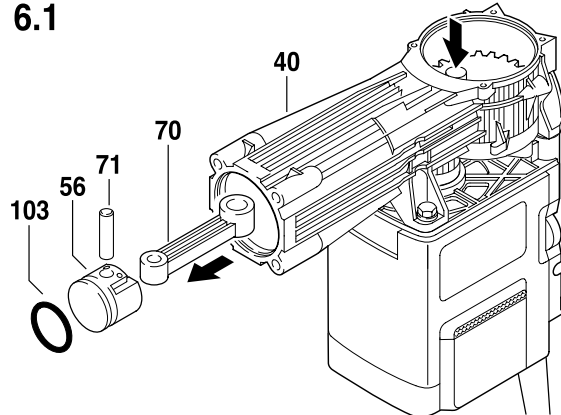

6.2

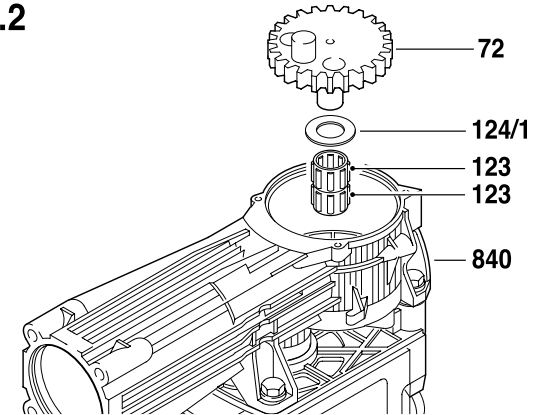

6.3

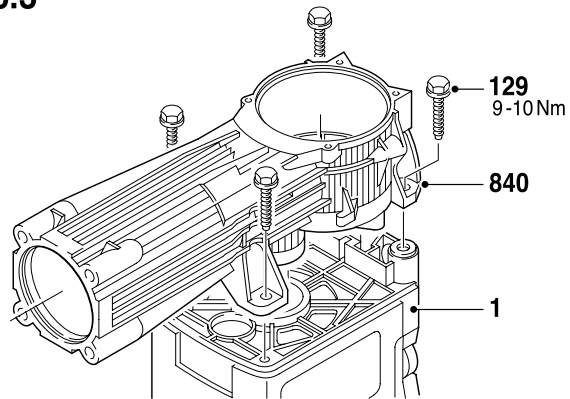

6.4

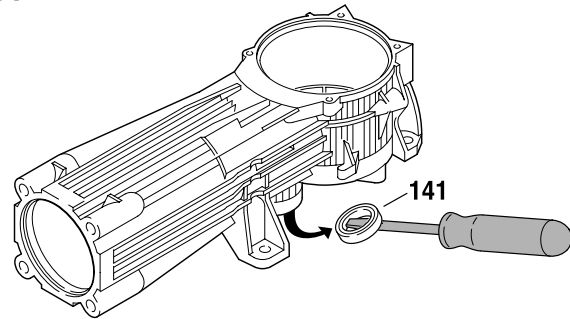

6.5

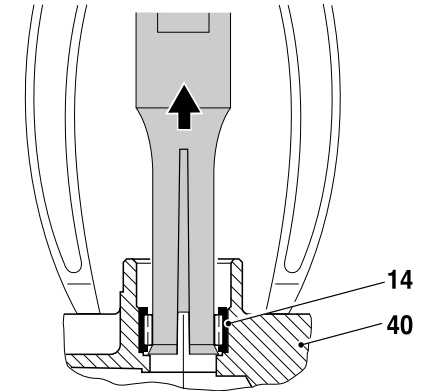

7.

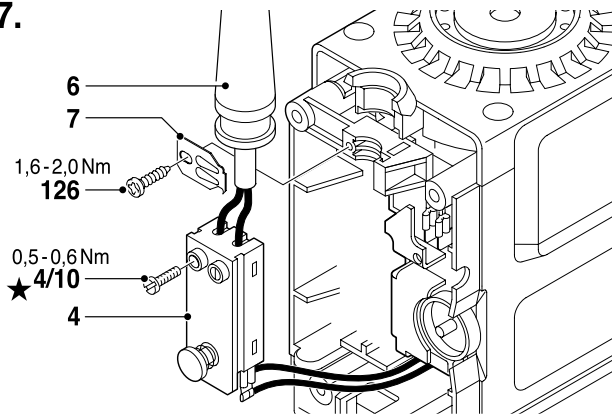

7.1

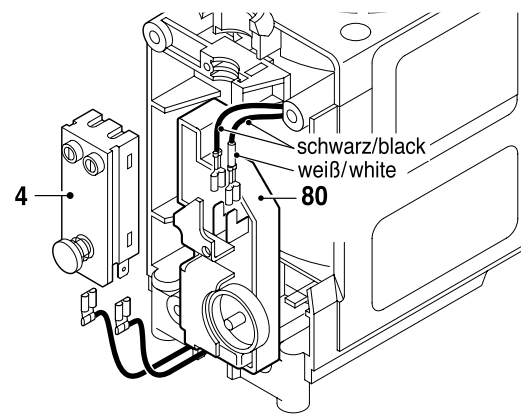

8.

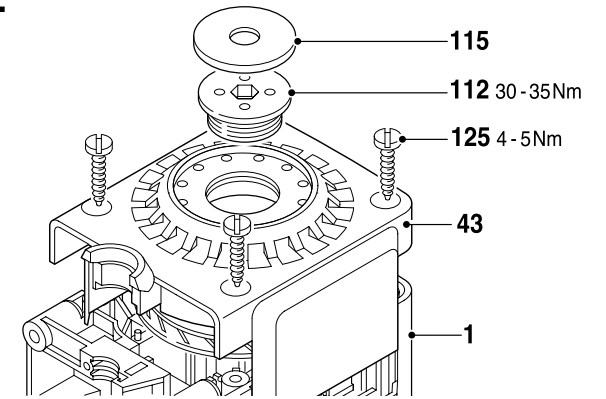

9.

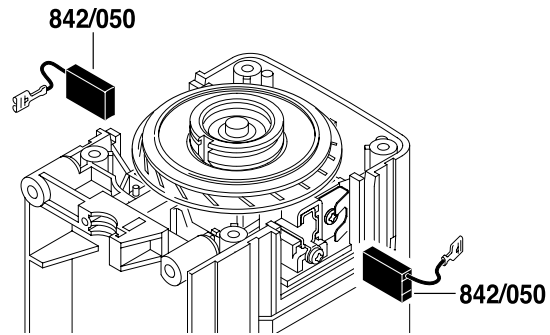

9.1

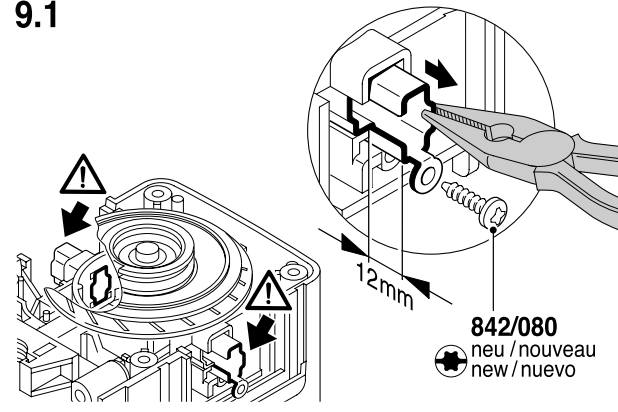

10.

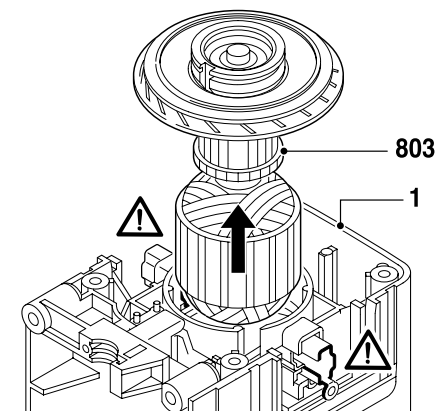

10.1

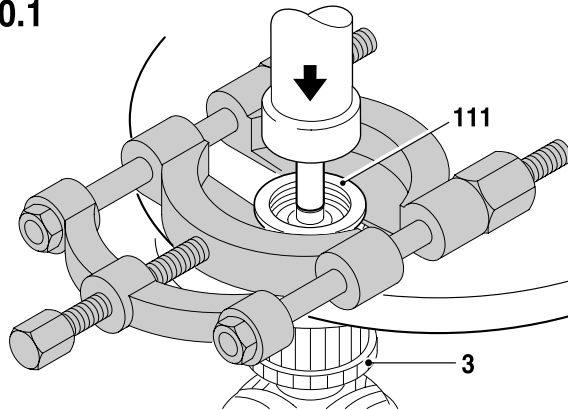

10.2

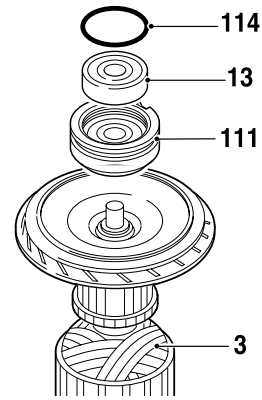

10.3

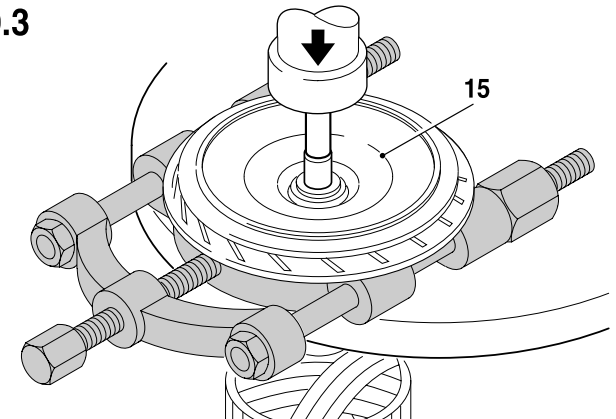

10.4

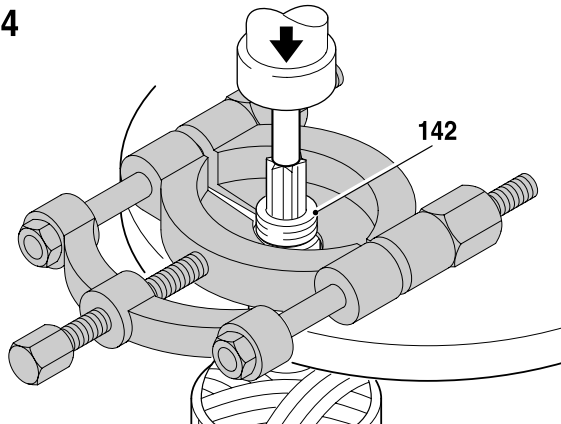

11.

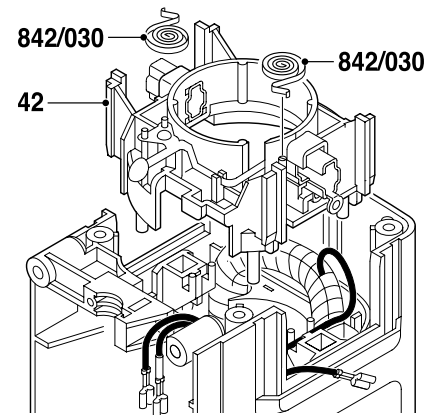

12.

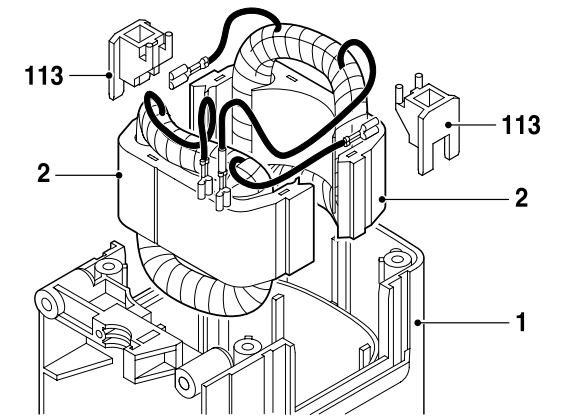

### Zusammenbau

Montage nach Explosionszeichnung und diesem Instandsetzungshinweis.

Alle Teile sind gereinigt, abgenutzte und beschädigte Teile werden ersetzt.

Nur Original-Ersatzteile verwenden.

Zähne aller Zahnräder mit Fett **1 615 430 001** bestreichen.

Bitte Schmierhinweise beachten!

### Assembly

Assembly using explosion drawings and these repair instructions!

Clean all parts, replace worn-out and damaged parts.

Use only original spare parts!

Grease all gear teeth **1 615 430 001**.

Please note lubrication instructions!

### Montage

Le montage s'effectue selon la vue éclatée et les instructions de réparation suivantes.

Toutes les pièces sont nettoyées, les pièces usées ou endommagées doivent être remplacées par des nouvelles. Pour le remplacement de pièces, n'utiliser que des pièces d'origine.

Les dents graisser **1 615 430 001**.

Respecter les instructions de graissage!

### Montaje

Realizar el montaje conforme a los dibujos en perspectiva y a estas instrucciones de reparación.

Todas las piezas deben estar limpias. Las piezas desgastadas o danadas deben reemplazarse por piezas nuevas. Utilizar solamente piezas de repuesto originales.

Dientes engrasar **1 615 430 001**.

Observar las instrucciones de lubricación!

21.

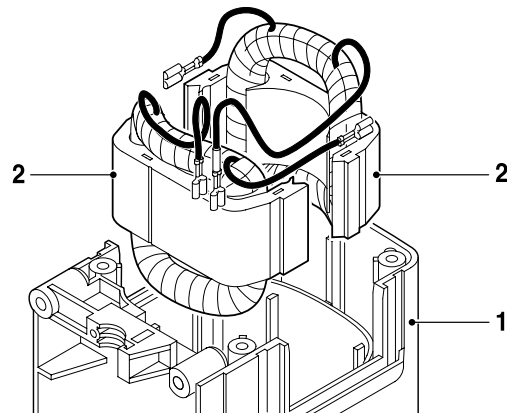

21.1

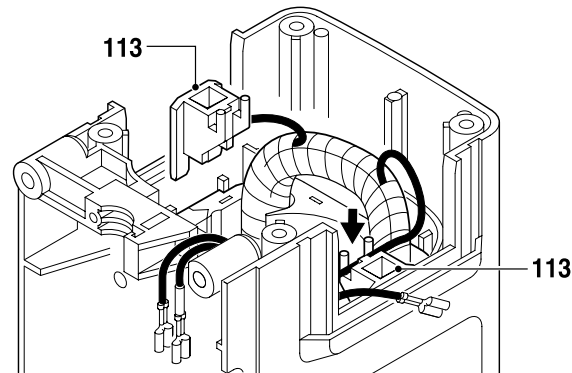

22.

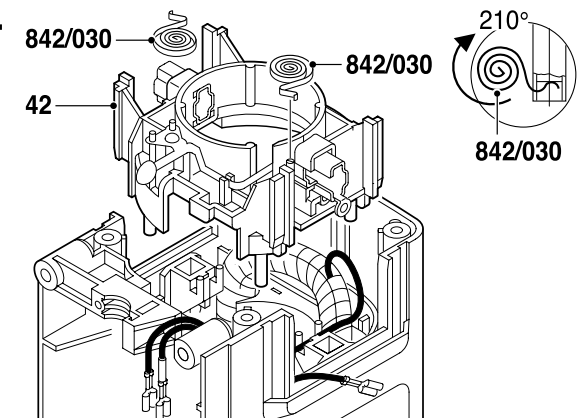

23.

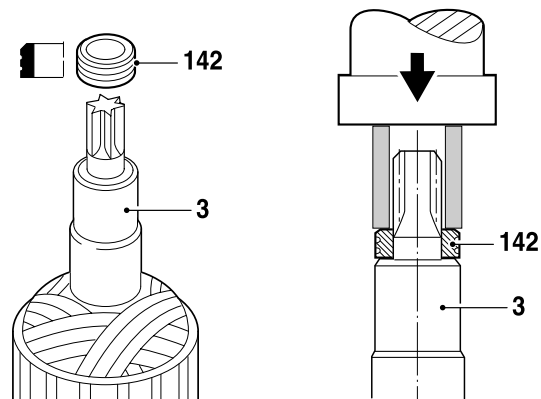

23.1

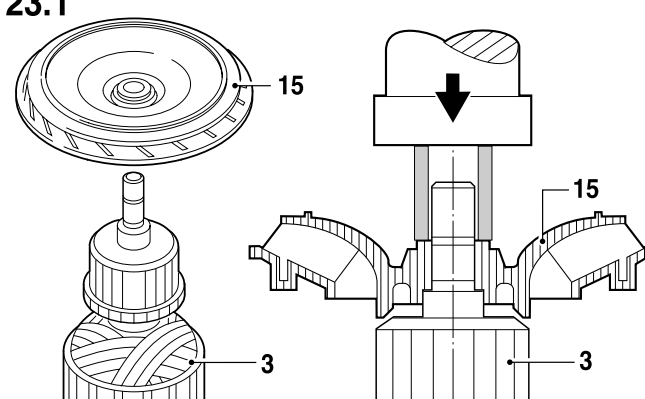

23.2

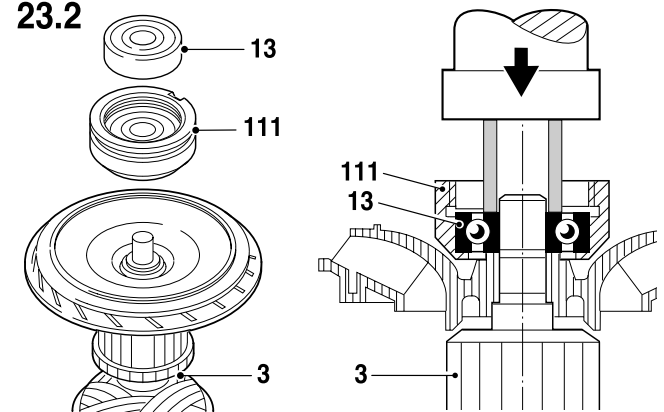

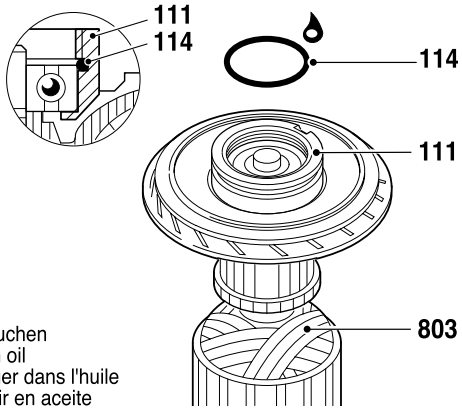
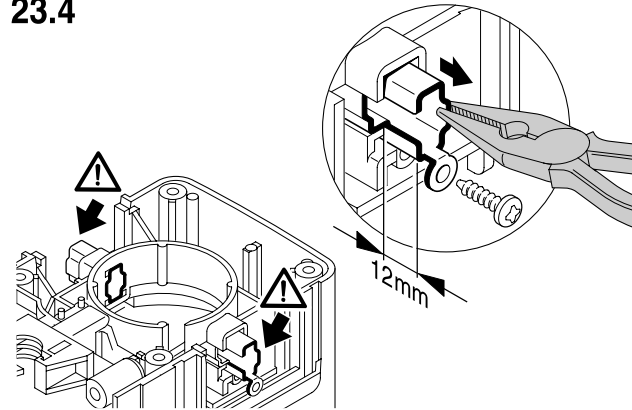
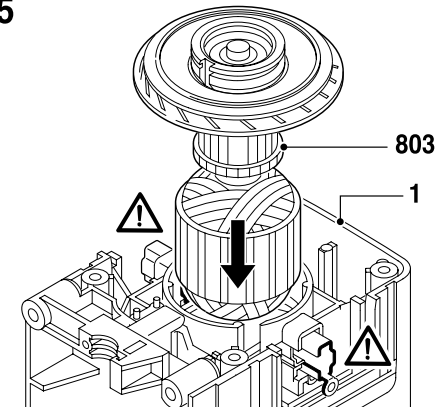
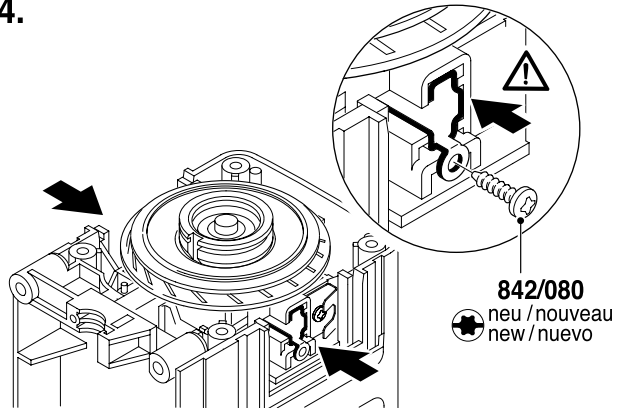
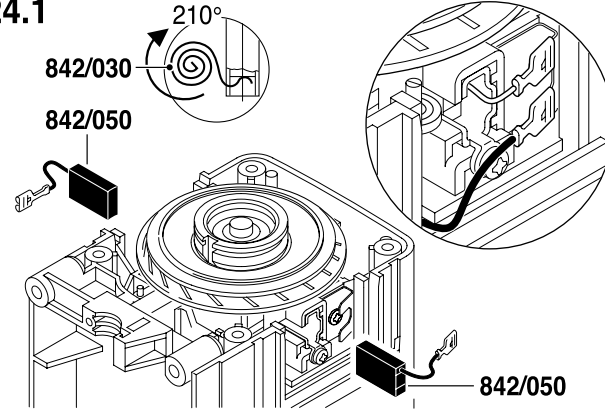
**23.3****23.4****23.5****24.****24.1****24.2**

Einbaulage beachten  
Check installation position  
Attention au positionnement  
Téngase en cuenta  
la posición de montaje

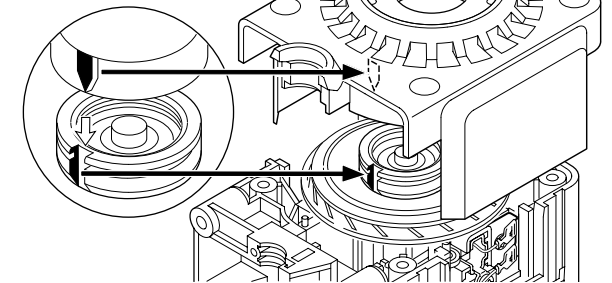
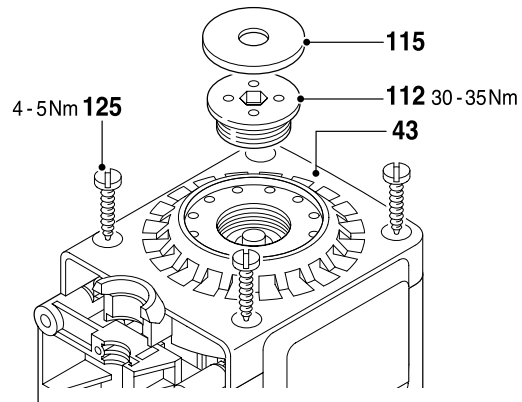
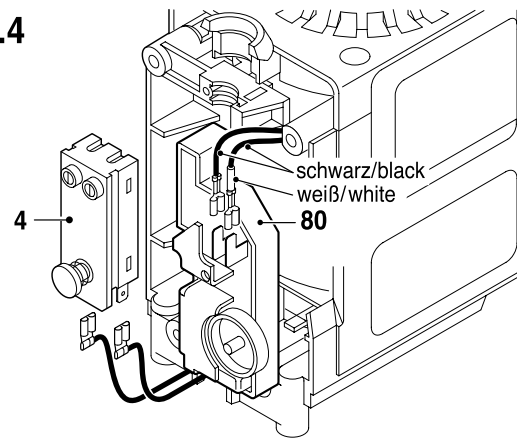
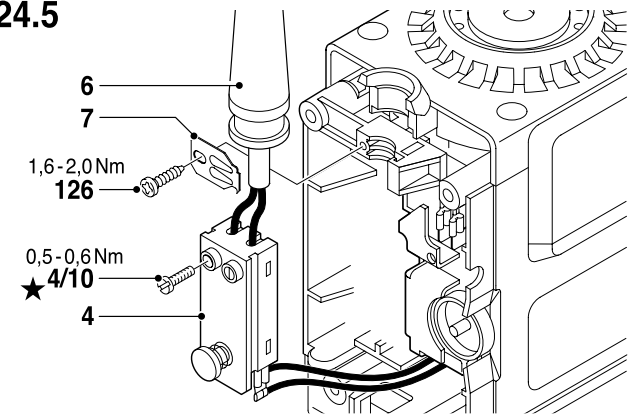
**24.3****24.4****24.5**

25.

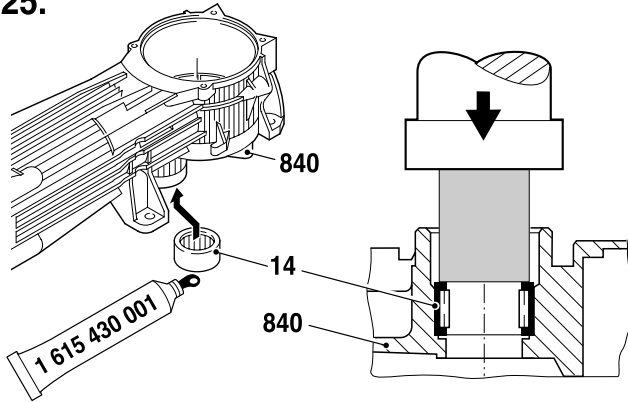

25.1

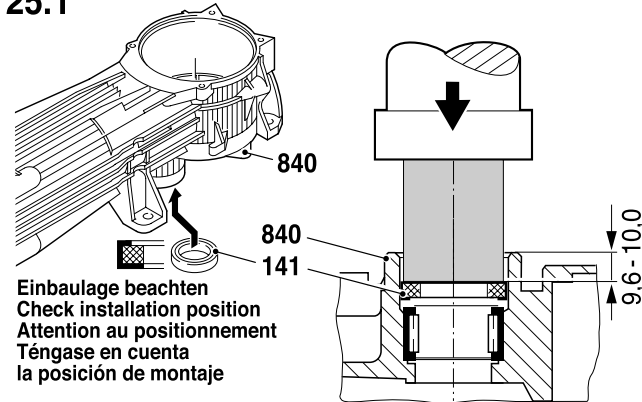

25.2

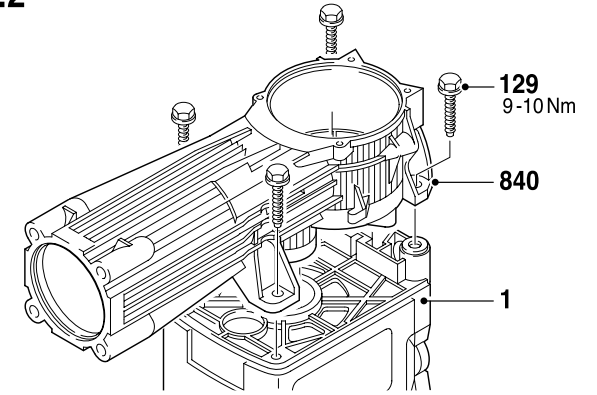

25.3

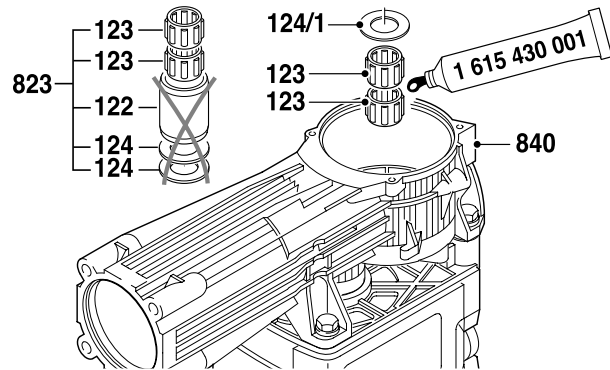

25.4

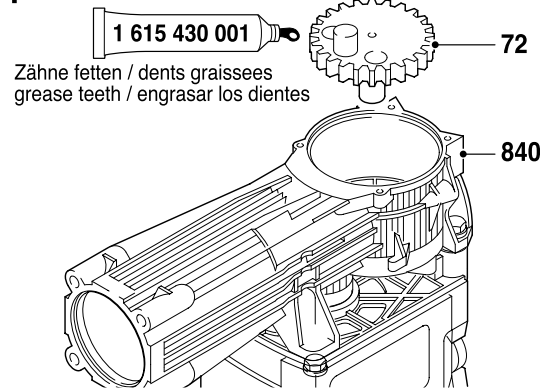

25.5

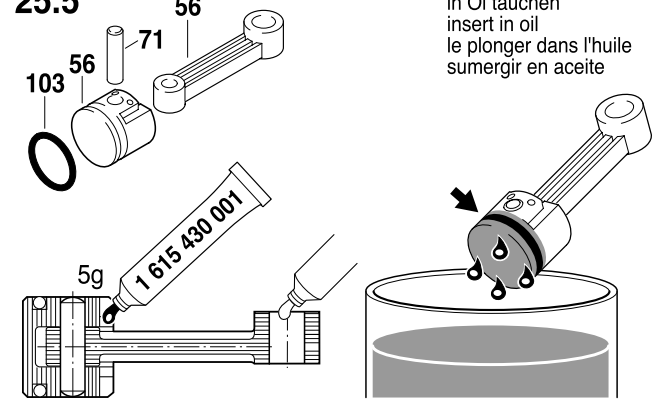

25.6

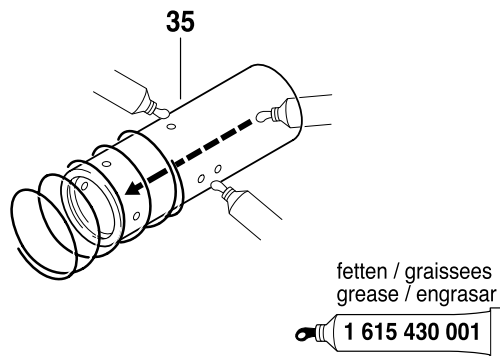

25.7

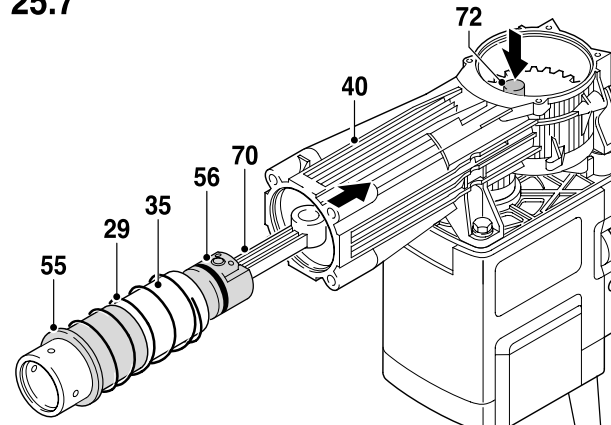

25.8

Pos. 35, 56, 57, 70 fetten (75 - 80g);  
 Rest in Getrieberraum Pos. 40.  
 Grease the parts pos. 35, 56, 57, 70 (75 - 80g);  
 rest into gear compartment pos. 40.  
 Graisser les pieces pos. 35, 56, 57, 70 (75 - 80g);  
 la graisse restante dans le compartiment d'engrenage pos. 40.  
 Engrasar las piezas pos. 35, 57, 70 (75 - 80g);  
 resto en el compartimento del engranaje pos. 40.

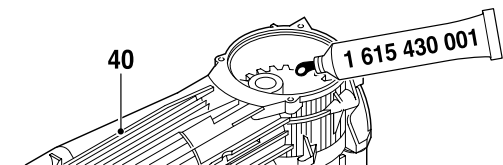



26.

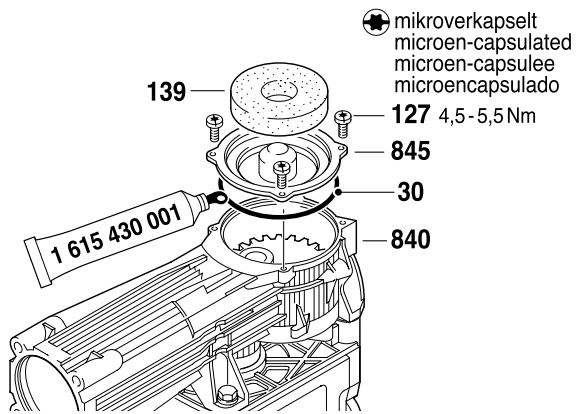

26.1

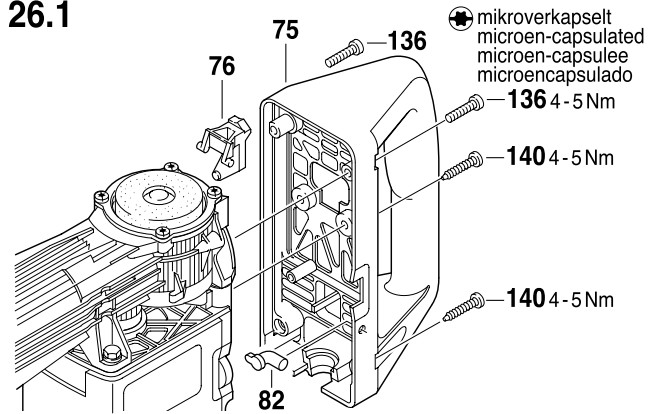

26.2

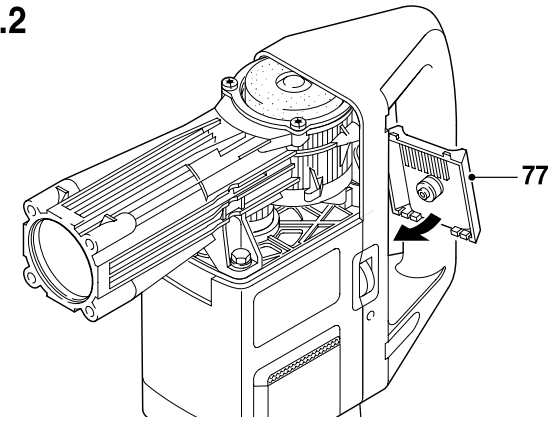

26.3

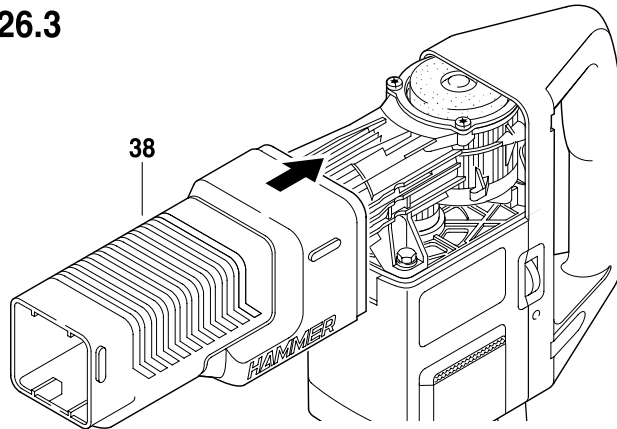

27.

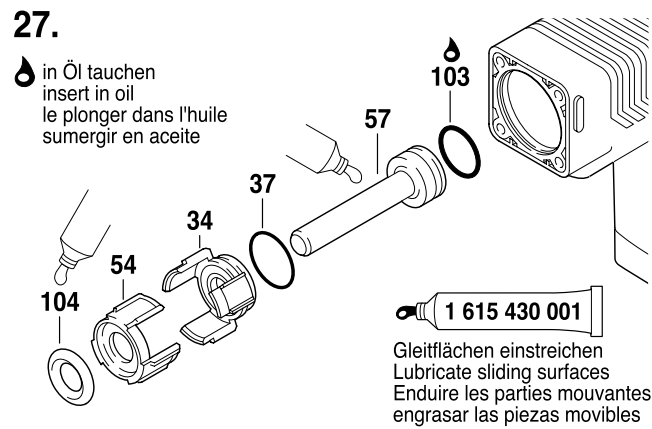

27.1

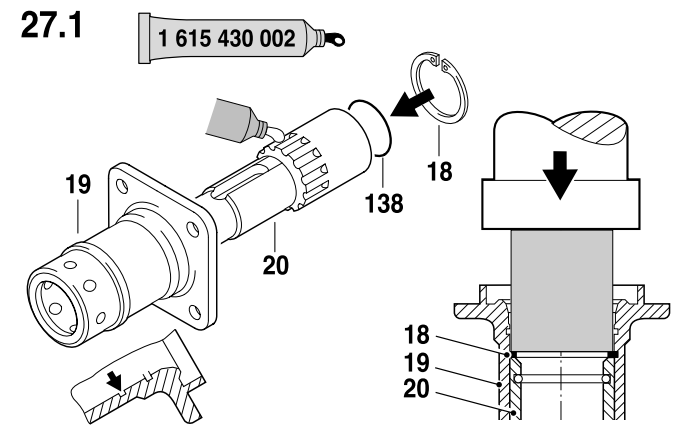

27.2

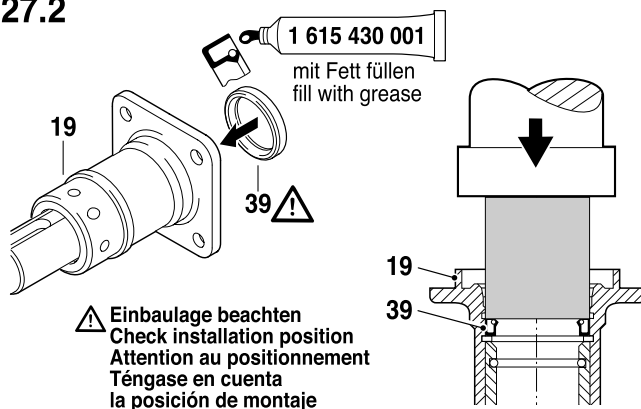

27.3

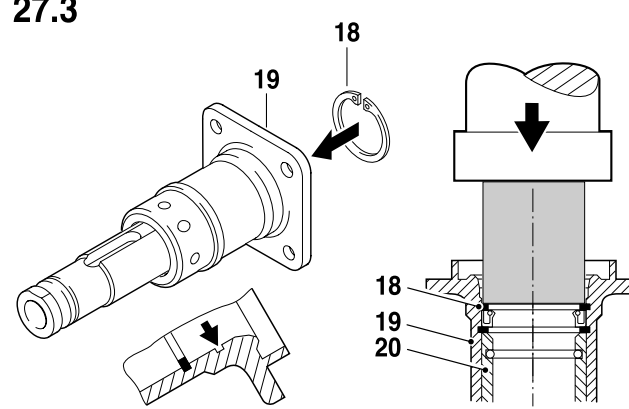

27.4

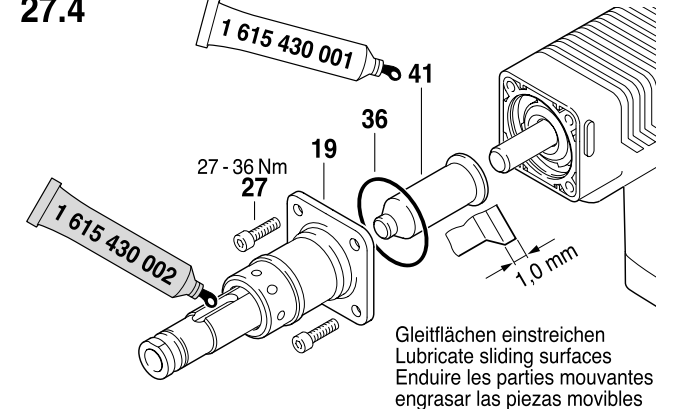

28.

Nase fetten / grease nose  
graisser nez / engrasar nesar

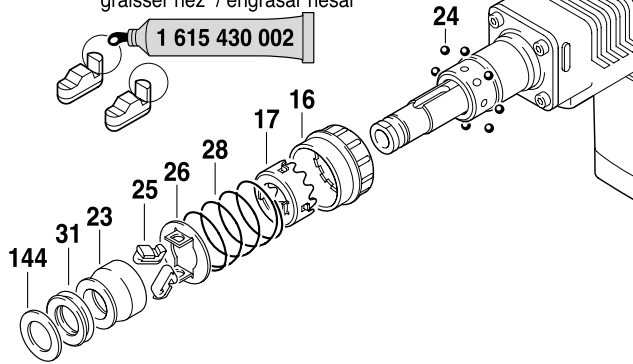

28.1

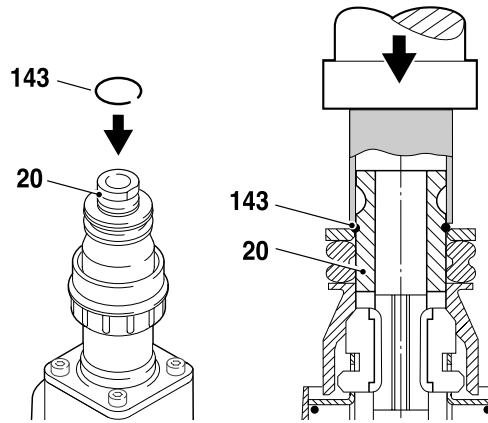

28.2

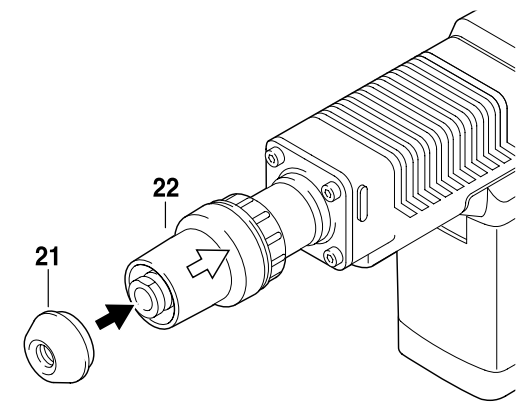

29.

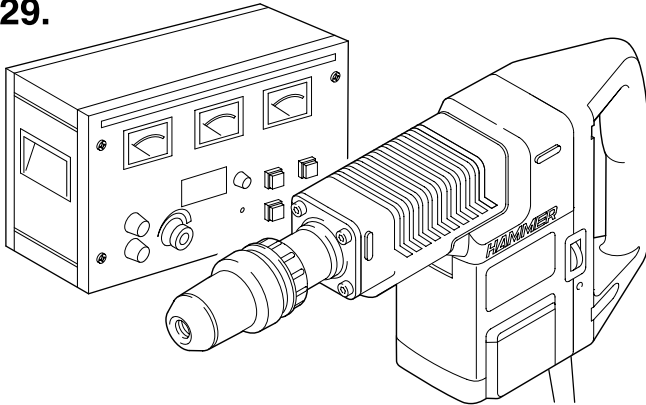

29. Hochspannungsprüfung durchführen.  
**Beachten:**  
Die Sicherheitsvorschriften nach DIN, VDE, CEE, AFNOR und weitere in den einzelnen Ländern gültigen Vorschriften sind einzuhalten.
29. Carry out power supply check.  
**Attention:**  
Safety regulations according to DIN, VDE, CEE, AFNOR and further regulations applicable in individual countries must be observed.

29. Effectuer un contrôle à haute tension.  
**Attention:**  
Respecter les instructions de sécurité selon DIN, VDE, CEE, AFNOR et les autres instructions valables dans les pays respectifs.
29. Efectuar la prueba de alta tensión.  
**Atención:**  
Atenerse a las prescripciones de seguridad según DIN, VDE, CEE, AFNOR y a las prescripciones adicionales específicas que pudieran existir en los respectivos países.

30.

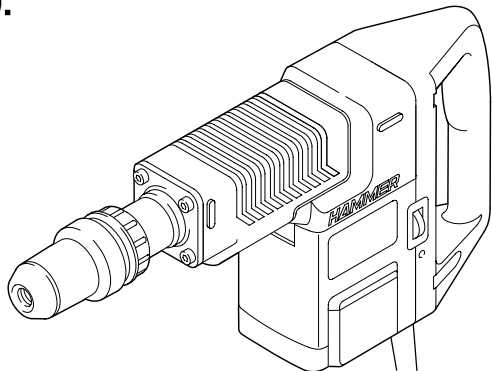

30. Probelauf, Schlagtest, elektrische und mechanische Prüfung durchführen.
30. Perform test run, impact test, electrical and mechanical check-up.

30. Marche à titre d'essai, contrôle de frappe et deperçage, effectuer un contrôle mécanique et électrique.
30. Realizar un control funcional, una prueba de taladrado con y sin percusión y los ensayos eléctricos y mecánicos correspondientes.

