

INSTANDSETZUNGSHINWEISE
REPAIR INSTRUCTIONS
INSTRUCTIONS DE REPARATION
INSTRUCCIONES DE REPARACION



Bohrhammer
Rotary Hammer
Marteau perforateur
Martillo perforador

Typ 3 611 C35 000 = GSH 16-28

Änderungen vorbehalten. Unsere Erzeugnisse werden stets dem neuesten technischen Stand angepaßt. Deshalb behalten wir uns Änderungen vor.

Modifications. Our products are constantly modified to meet new technical standards. We therefore reserve the right to alter data and specifications without prior notice.

Modifications. Nos produits sont continuellement adaptés aux dernières nouveautés techniques et les dates sont données sous réserve de changement.

Modificaciones. Nuestros fabricados van siendo adaptos constantemente a las últimas conquistas técnicas. Por ello, tenemos que reservarnos el derecho de introducir modificaciones en los datos técnicos.

Опубликовано на сайте www.rem-5.ru

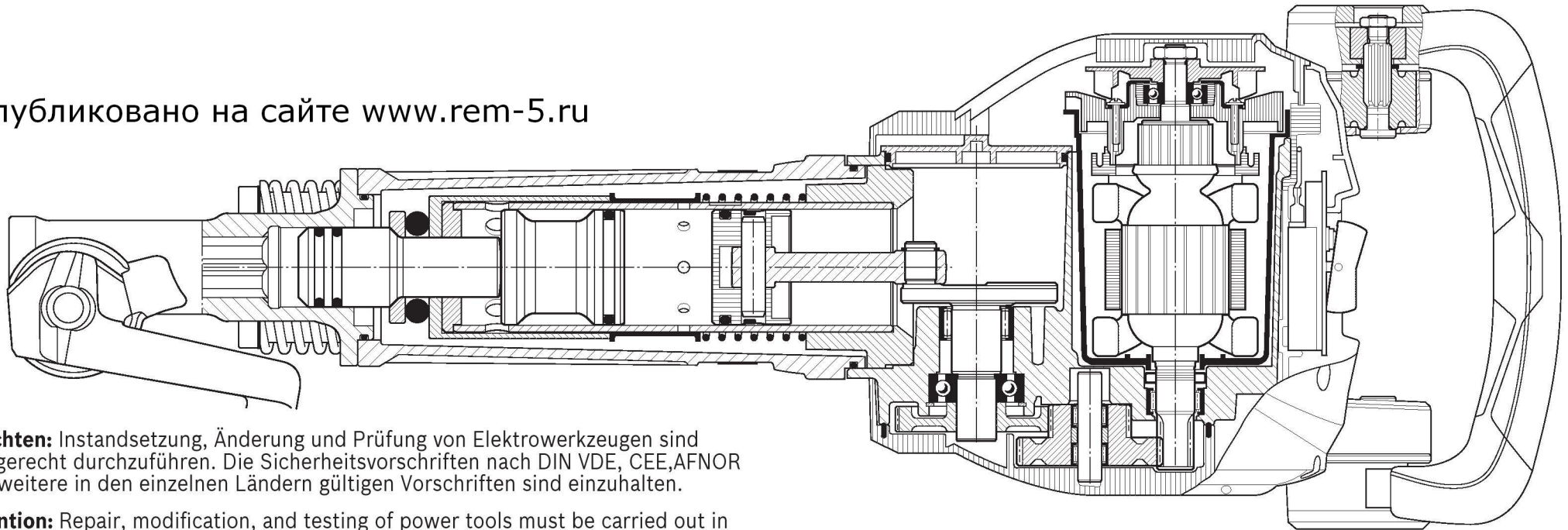

Beachten: Instandsetzung, Änderung und Prüfung von Elektrowerkzeugen sind fachgerecht durchzuführen. Die Sicherheitsvorschriften nach DIN VDE, CEE, AFNOR und weitere in den einzelnen Ländern gültigen Vorschriften sind einzuhalten.

Attention: Repair, modification, and testing of power tools must be carried out in accordance with the generally recognised principles of engineering practise. Safety regulations according to DIN VDE, CEE, AFNOR and further regulations applicable in individual countries must be observed.

Attention: La remise en état, la modification et le controle des outils électriques doivent être effectués par des personnes qualifiées. Il convient de respecter les prescriptions de sécurité selon DIN VDE, CEE, AFNOR, ainsi que les réglementations en vigueur dans le pays concerné.

Obsérvese: La reparación, modificación y verificación de herramientas electricas mano debe efectuarse en forma técnicamente correcta. Respetar las normas de seguridad segun DIN VDE, CEE, AFNOR, asi como otras disposiciones vigentes en los distintos paises.

Zerlegen

Für die Demontage werden handelsübliche Werkzeuge benötigt.

1. Eingangsprüfung durchführen.
Beachten:
Die Sicherheitsvorschriften nach DIN, VDE, CEE, AFNOR und weitere in den einzelnen Ländern gültigen Vorschriften sind einzuhalten.

Disassembly

Use normal trade tools by disassembly.

1. Carry out power supply check.
Attention:
Safety regulations according to DIN, VDE, CEE, AFNOR and further regulations applicable in individual countries must be observed.

Démontage

Pour le démontage, des outils en usage dans le commerce sont nécessaires.

1. Effectuer un contrôle préliminaire.
Attention:
Respecter les instructions de sécurité selon DIN, VDE, CEE, AFNOR et les autres instructions valables dans les pays respectifs.

Desmontaje

Para el desmontaje no se precisan herramientas especiales.

1. Realizar control de recepción.
Atención:
Atenerse a las prescripciones de seguridad según DIN, VDE, CEE, AFNOR y a las prescripciones adicionales específicas que pudieran existir en los respectivos países.

1.

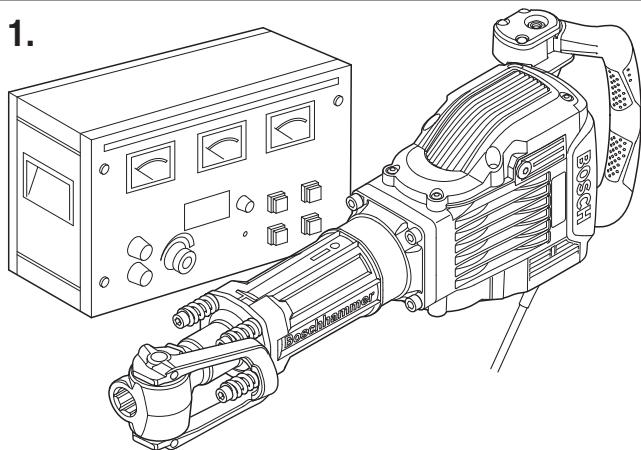

3.

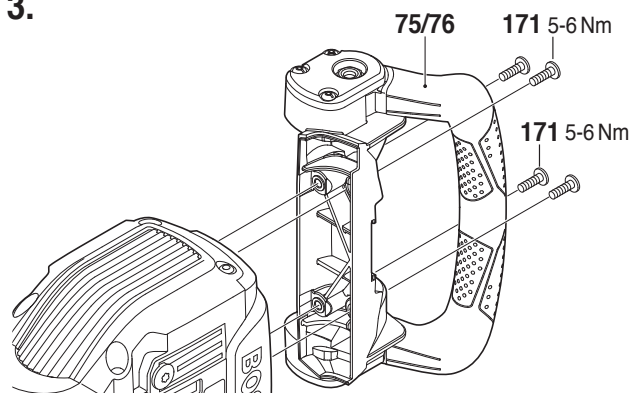

3.1

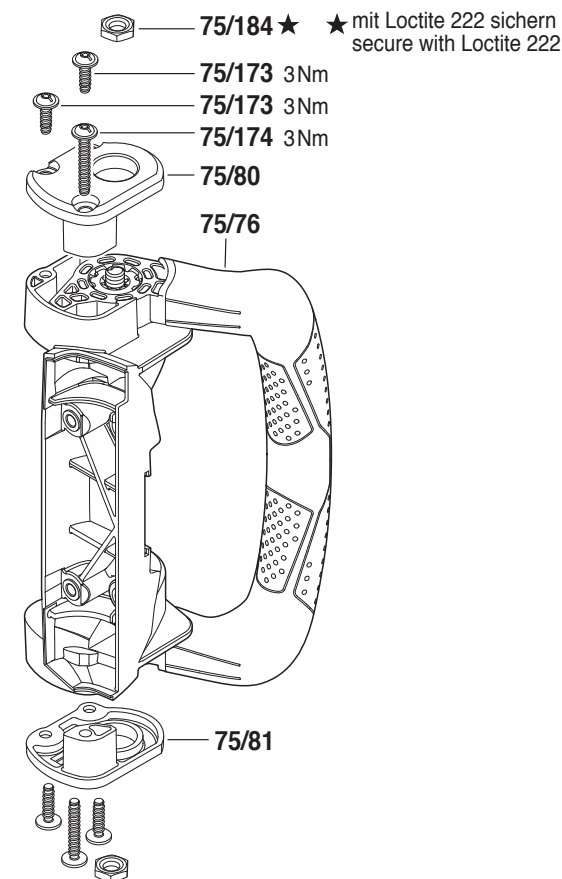

2.

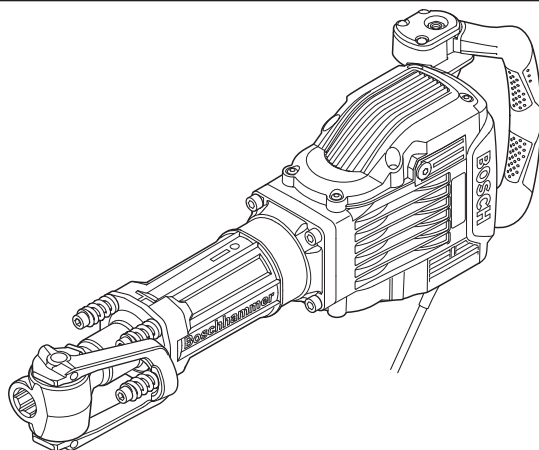

2. Zerlegen nach Explosions-, Schnittzeichnung und diesem Instandsetzungshinweis.
2. Disassembly using explosion, cut-away drawings and these repair instructions!
2. Démontez l'appareil suivant la vue éclatée, le plan en coupe et ces instructions de réparation.
2. Realizar el desmontaje conforme a los dibujos en perspectiva y en sección, y a estas instrucciones de reparación.

3.2.

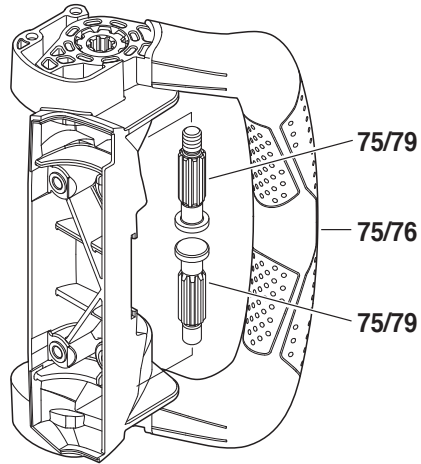

3.3

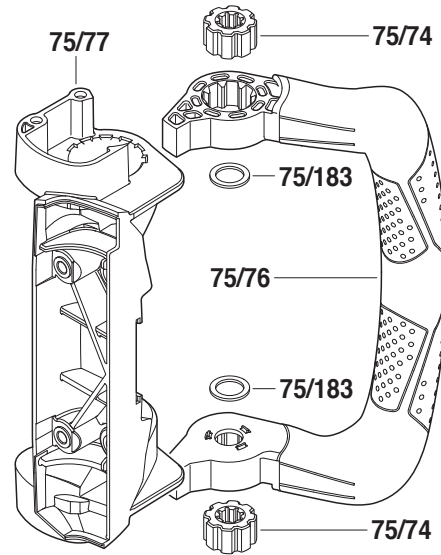

3.4

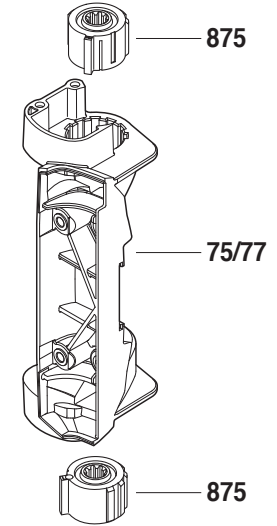

4.

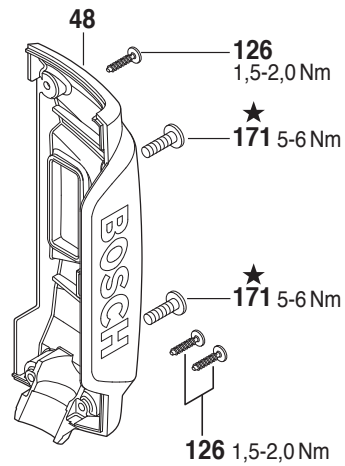
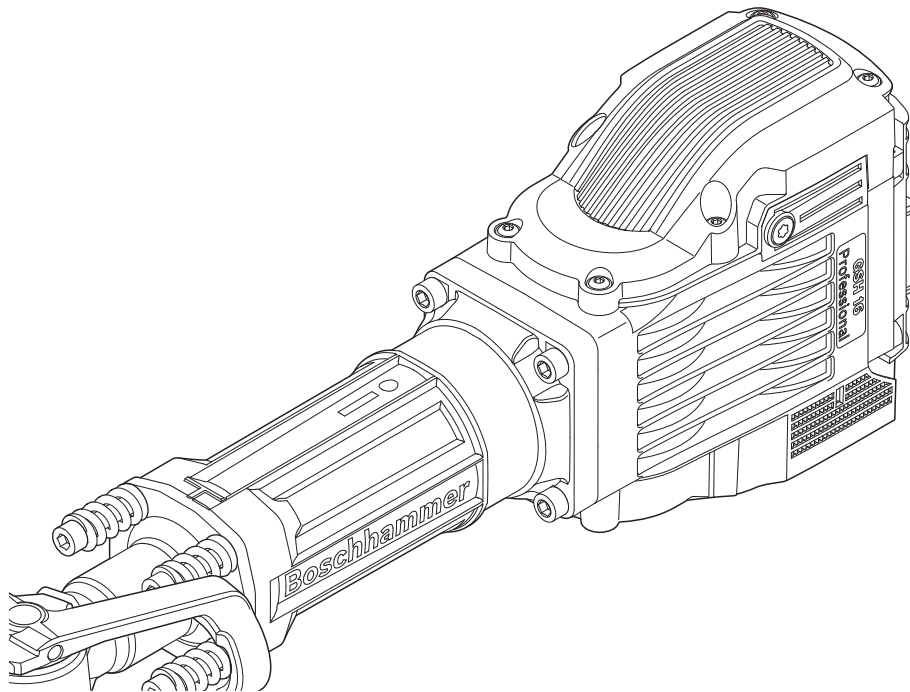

★ mit Loctite 222 gesichert
secured with Loctite 222

4.1

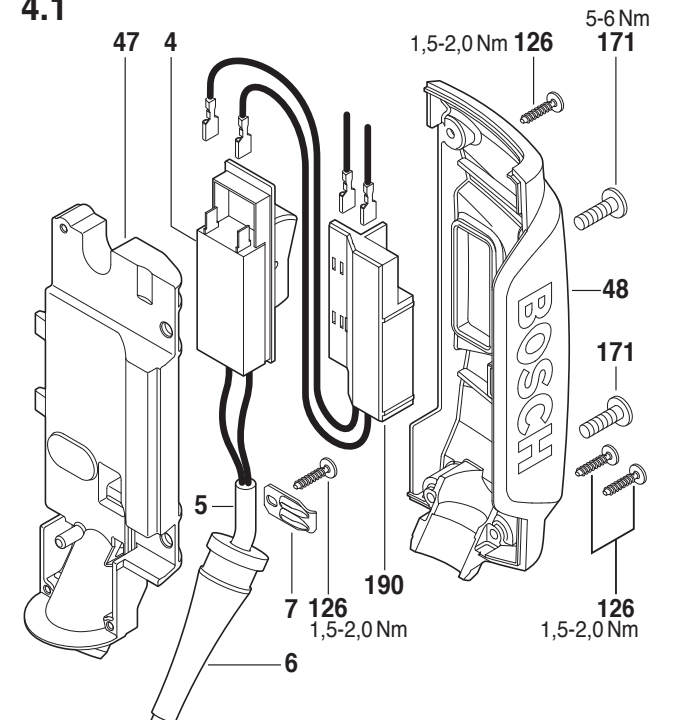

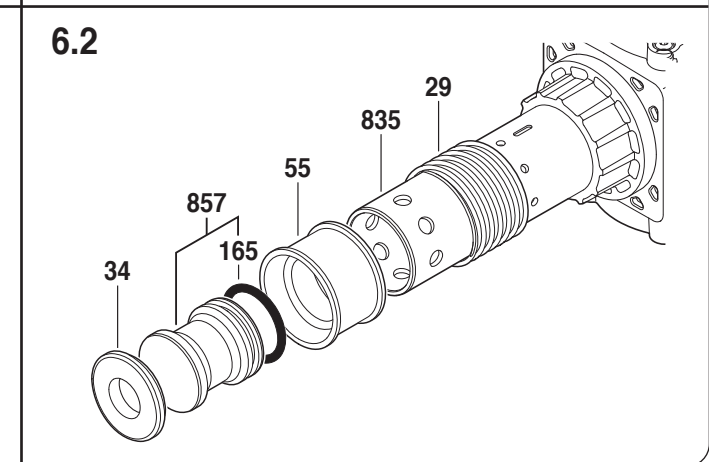
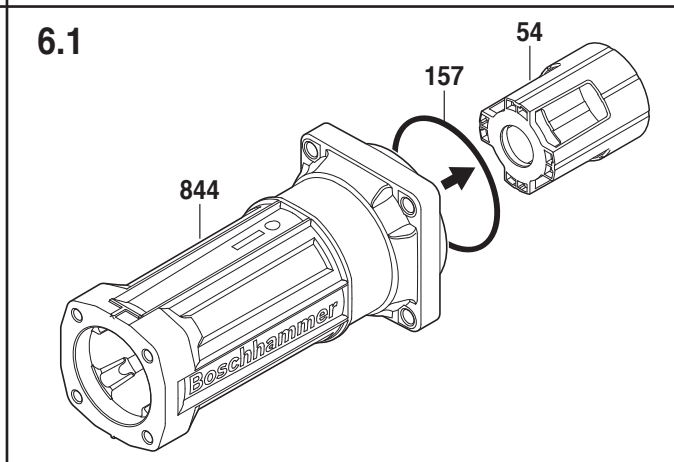
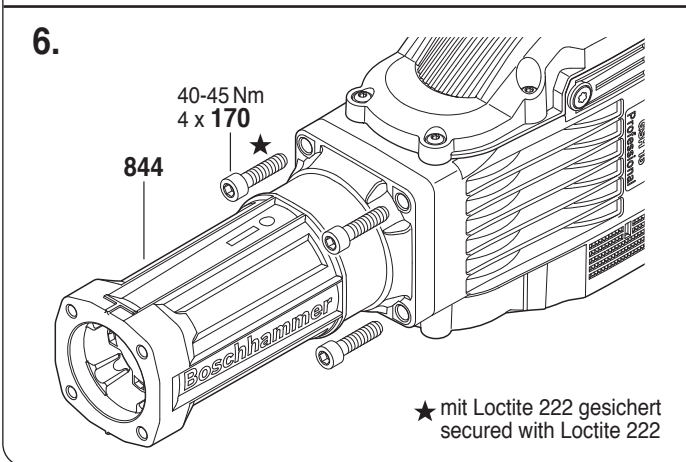
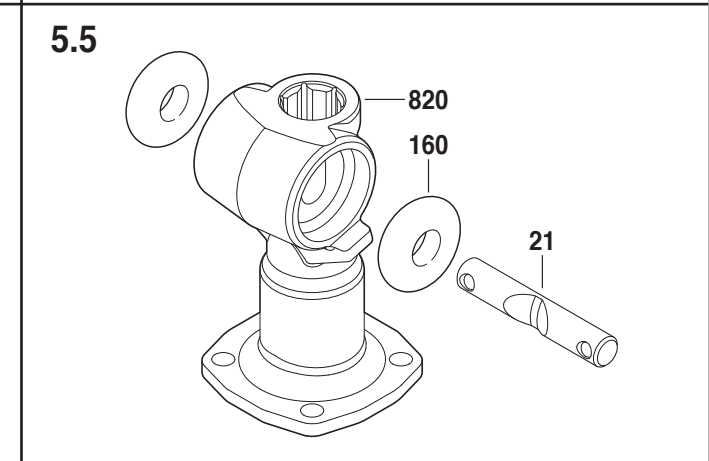
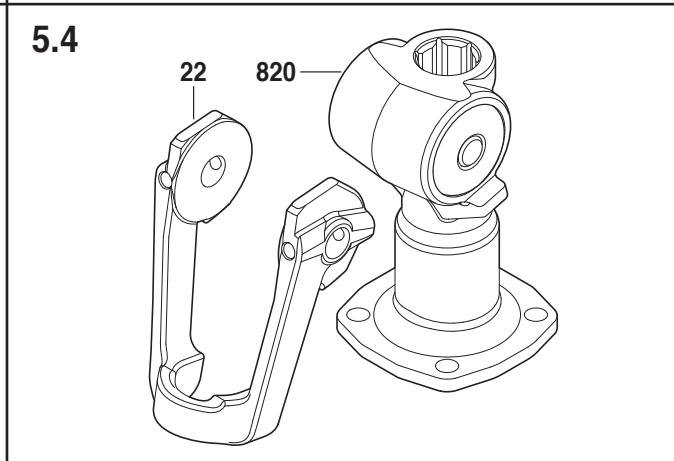
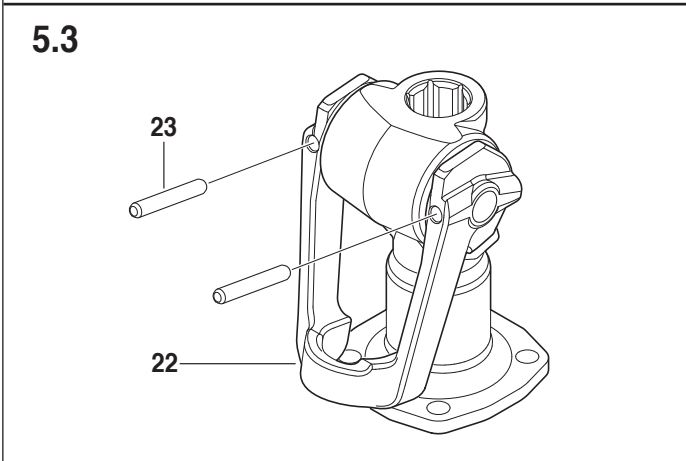
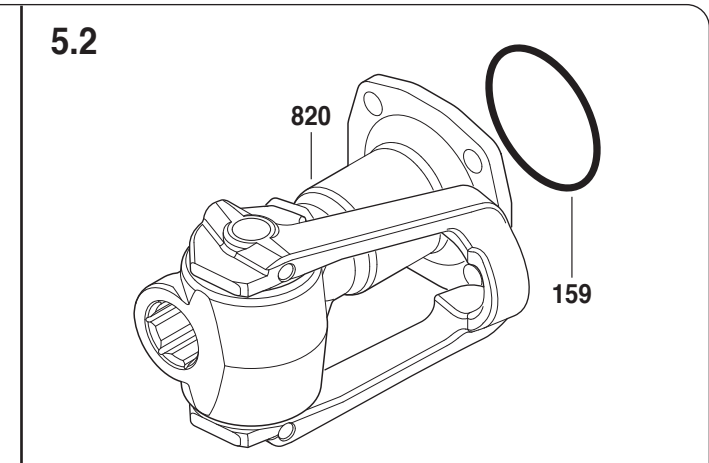
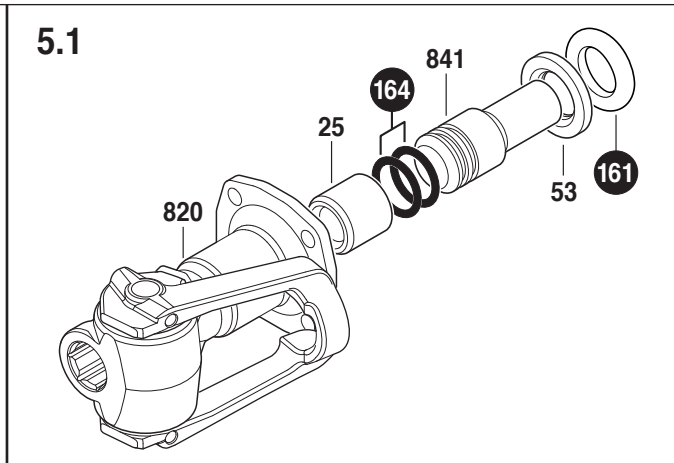
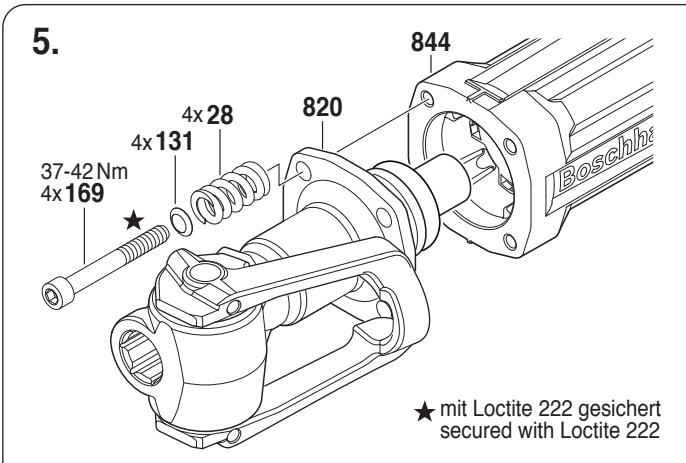

6.3

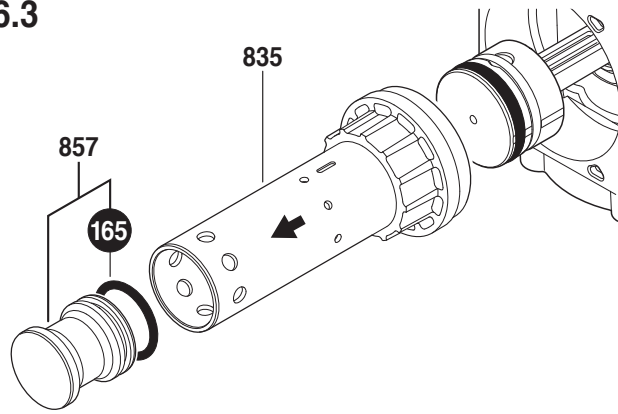

6.4

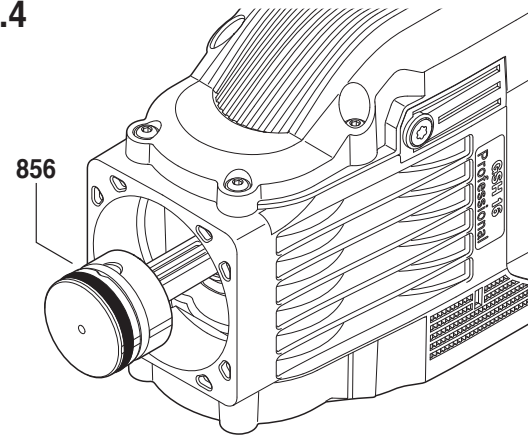

6.5

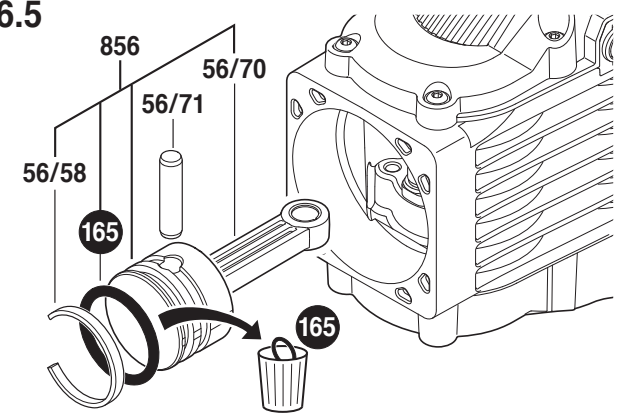

7.

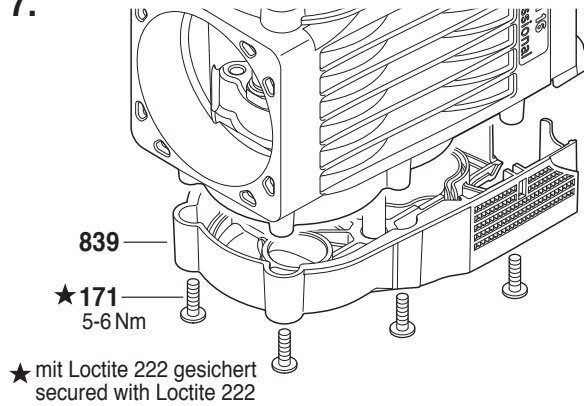

7.1

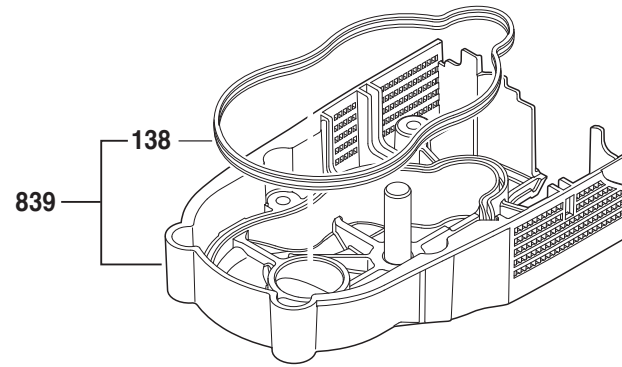

7.2

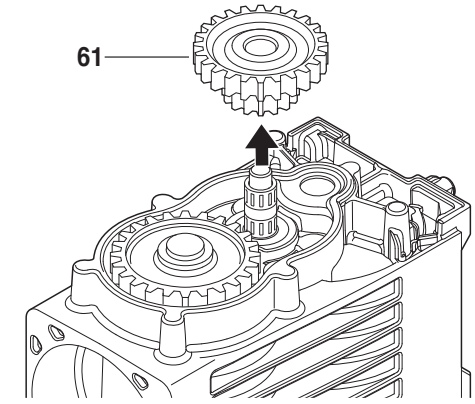

7.3

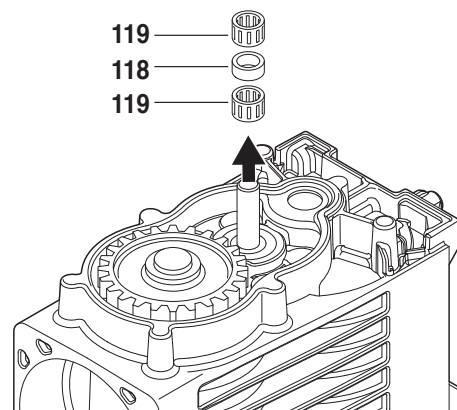

8.

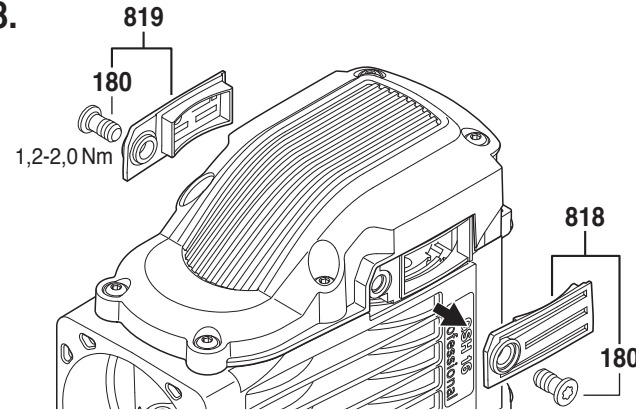

8.1

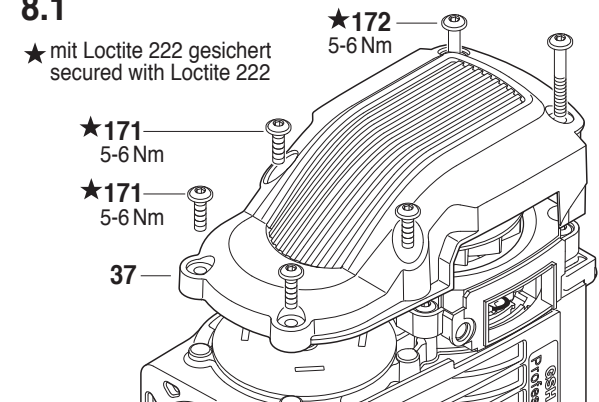

8.2

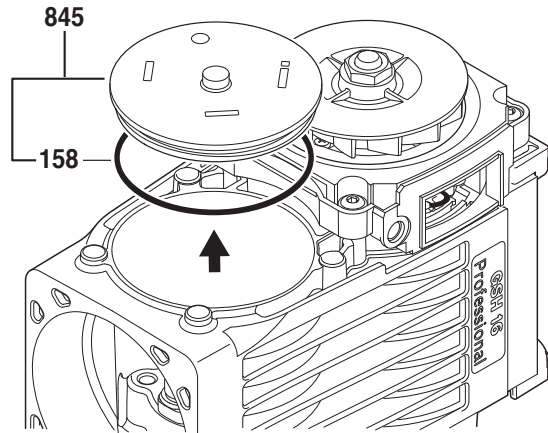

8.3

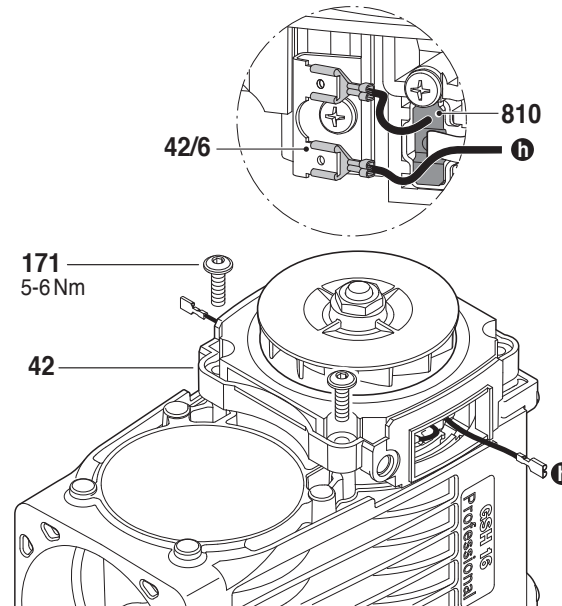

8.4

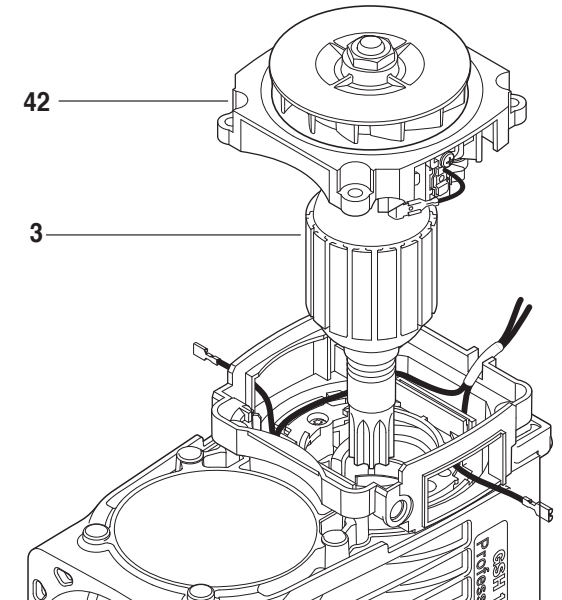

8.5

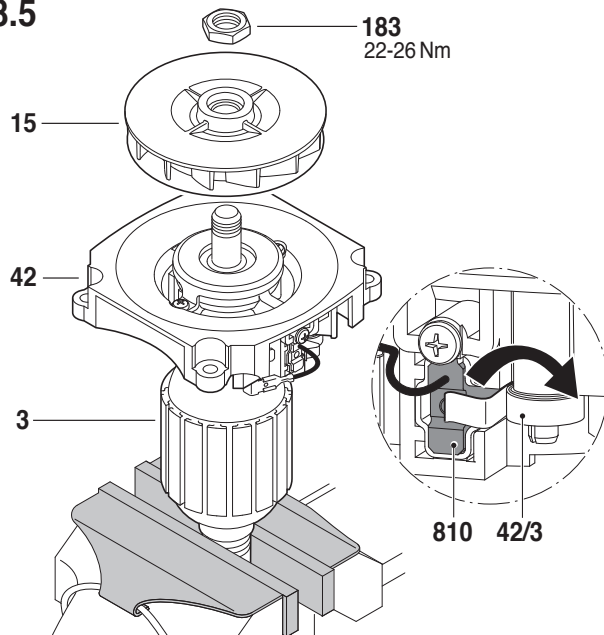

8.6

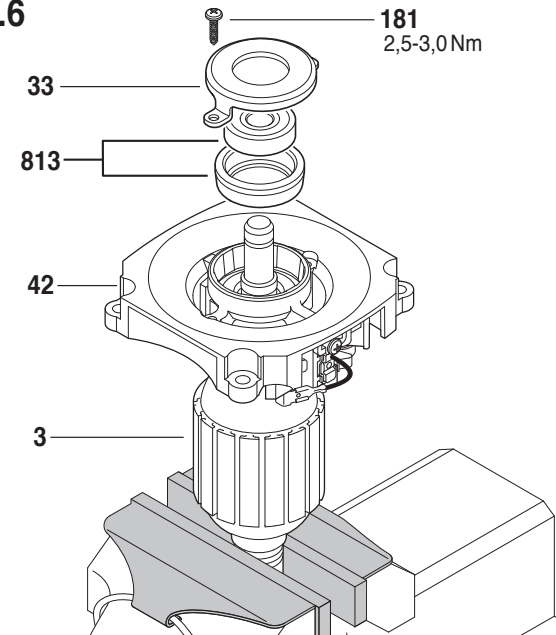

8.7

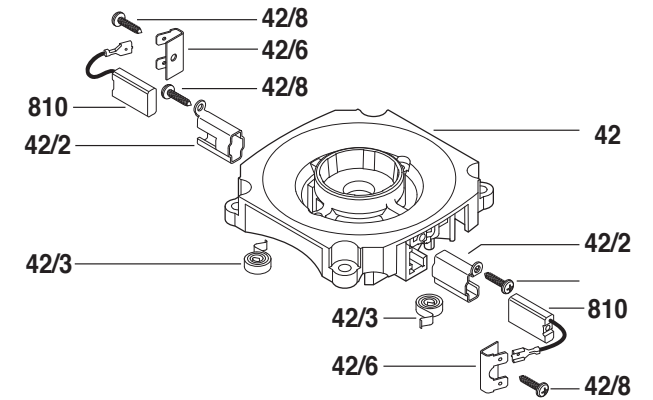

9.

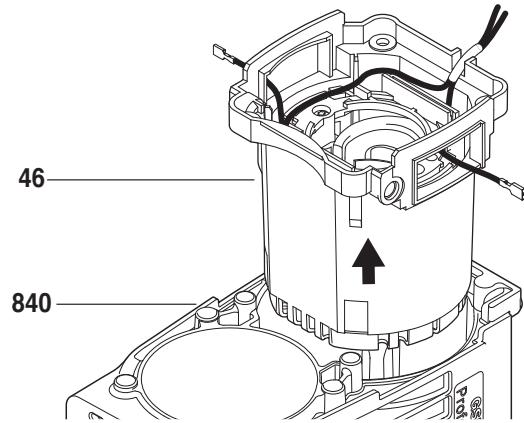

9.1

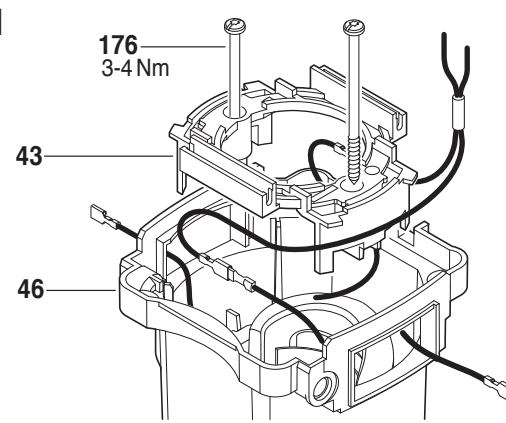

9.2

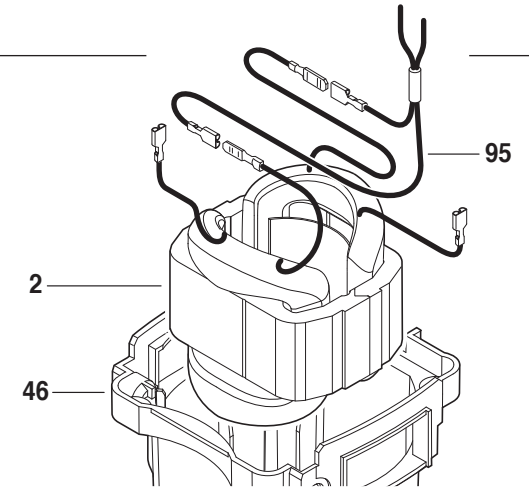

10.

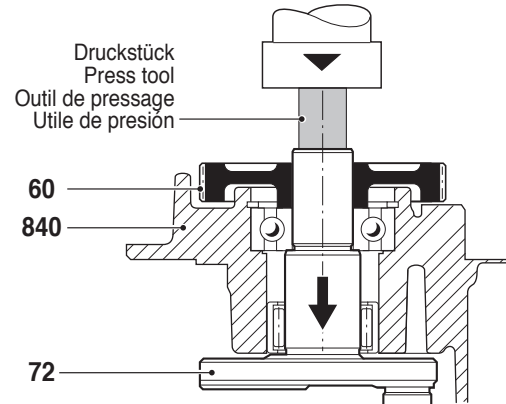
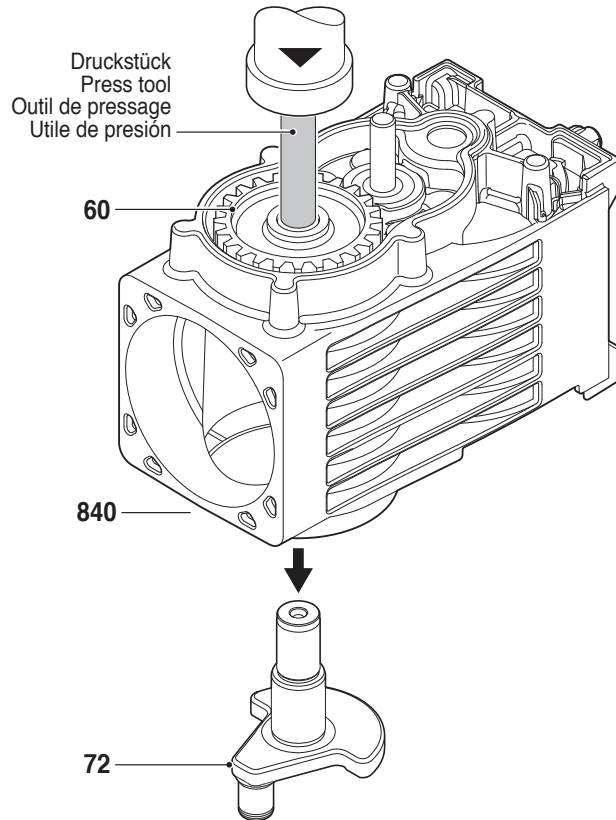

10.1

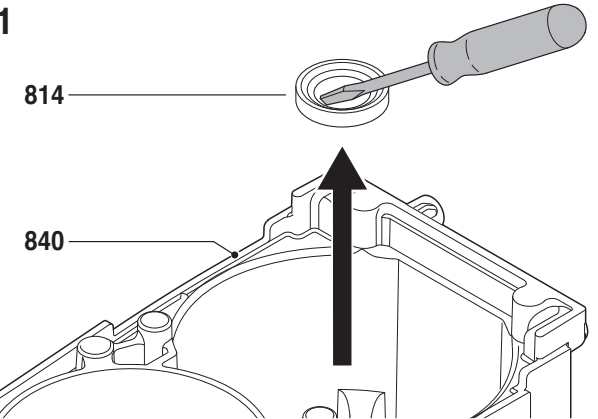

10.2

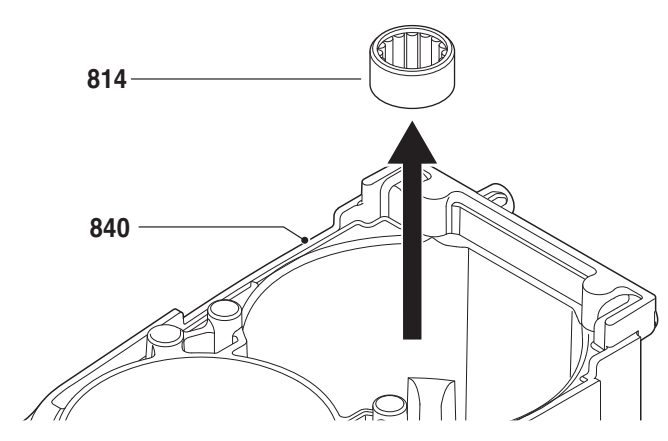
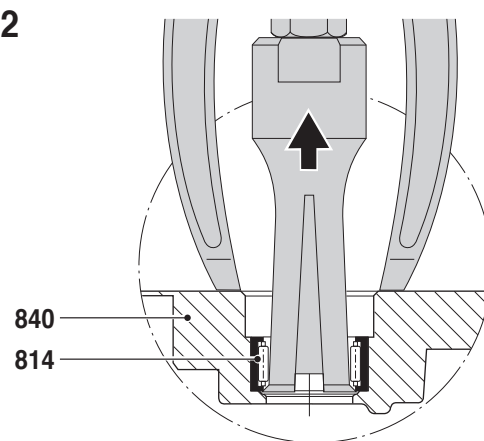

10.3

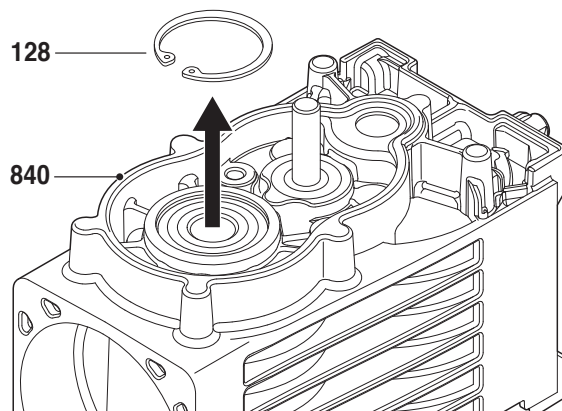
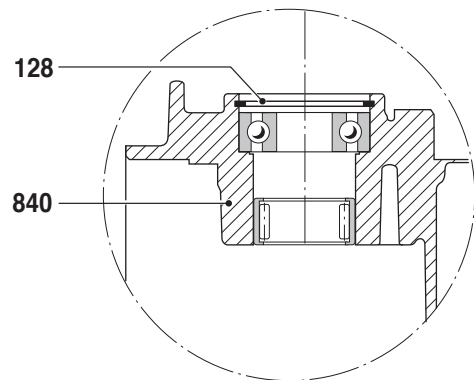

10.4

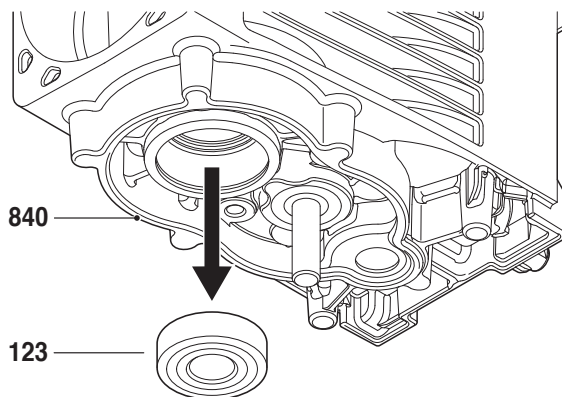
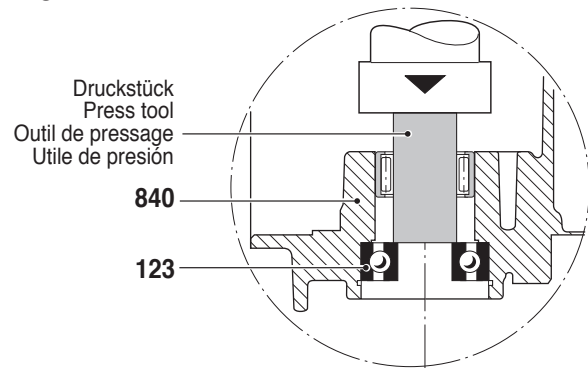

10.5

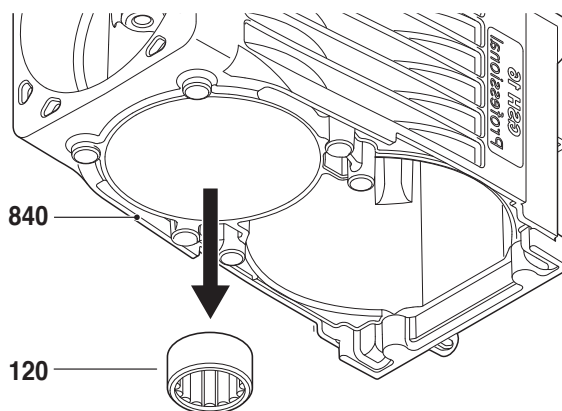
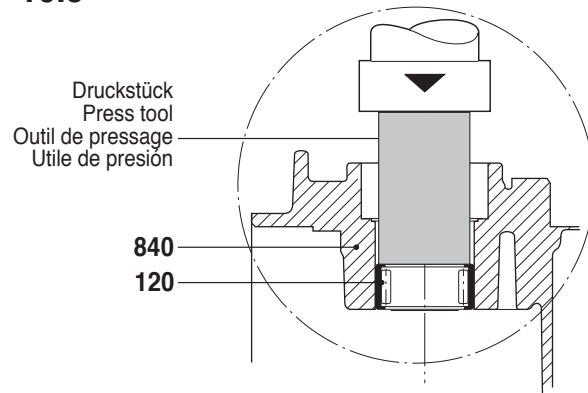

Zusammenbau

Montage nach Explosionszeichnung und diesem Instandsetzungshinweis.

Alle Teile sind gereinigt, abgenutzt und beschädigte Teile werden ersetzt.

Nur Original-Ersatzteile verwenden.

Zähne aller Zahnräder mit Fett **1 615 430 001** bestreichen.

Bitte Schmierhinweise beachten!

Assembly

Assembly using explosion drawings and these repair instructions!

Clean all parts, replace worn-out and damaged parts.

Use only original spare parts!

Grease all gear teeth **1 615 430 001**.

Please note lubrication instructions!

Montage

Le montage s'effectue selon la vue éclatée et les instructions de réparation suivantes.

Toutes les pièces sont nettoyées, les pièces usées ou endommagées doivent être remplacées par des nouvelles. Pour le remplacement de pièces, n'utiliser que des pièces d'origine.

Les dents graisser **1 615 430 001**.

Respecter les instructions de graissage!

Montaje

Realizar el montaje conforme a los dibujos en perspectiva y a estas instrucciones de reparación.

Todas las piezas deben estar limpias. Las piezas desgastadas o dañadas deben reemplazarse por piezas nuevas. Utilizar solamente piezas de repuesto originales.

Dientes engrasar **1 615 430 001**.

Observar las instrucciones de lubricación!

21.

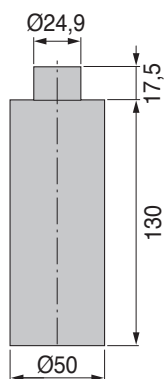

Hilfswerkzeug zum Selbstanfertigen
Auxiliary tool (for your own manufacture)
Outil auxiliaire (fabrication locale)
Utile (fabricación particular)

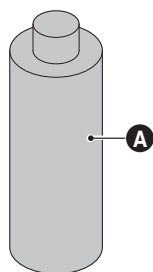

Maße in mm
Dimensions in mm
Cotes en mm
Medidas en mm

Montagedorn
Mounting pin
Arbre de montage
Punzón de montaje

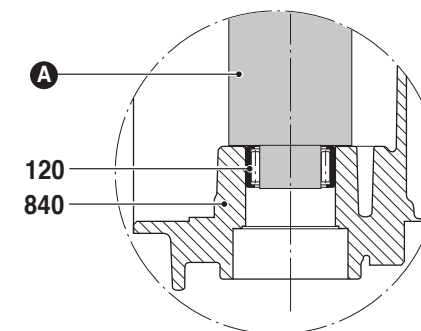
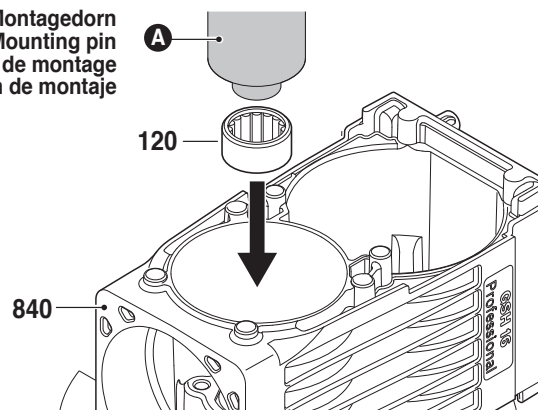

21.1

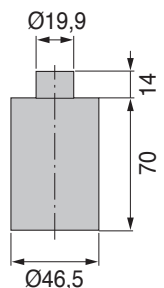

Hilfswerkzeug zum Selbstanfertigen
Auxiliary tool (for your own manufacture)
Outil auxiliaire (fabrication locale)
Utile (fabricación particular)

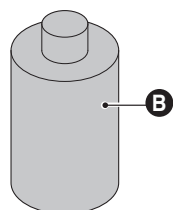

Maße in mm
Dimensions in mm
Cotes en mm
Medidas en mm

Montagedorn
Mounting pin
Arbre de montage
Punzón de montaje

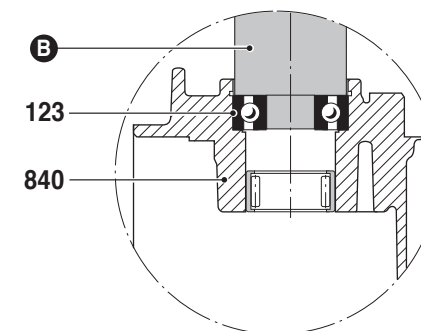
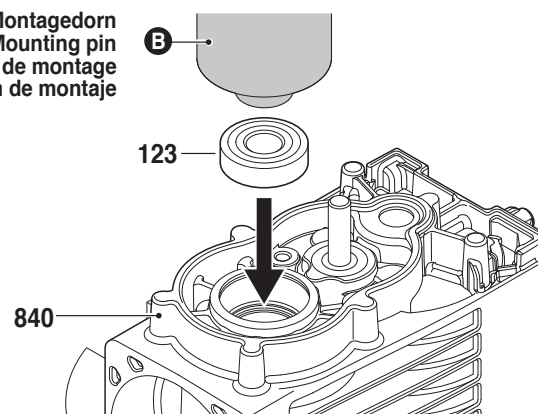

21.2

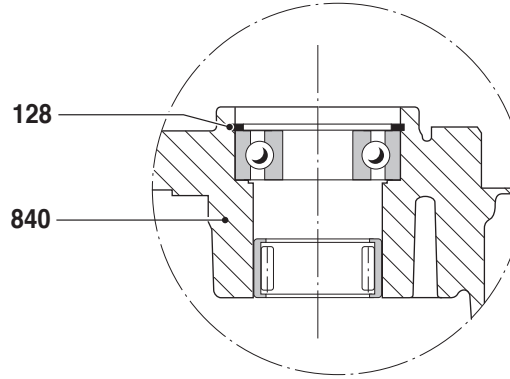
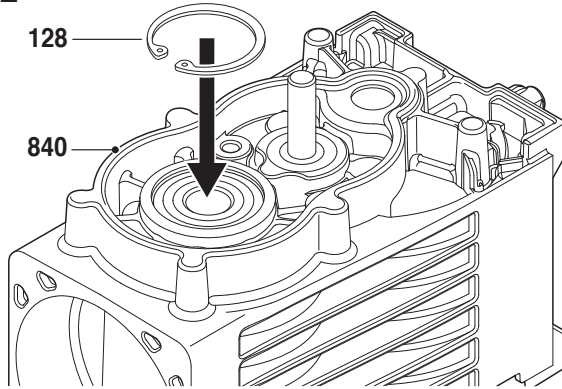

21.3

Hilfswerkzeug zum Selbstanfertigen
 Auxiliary tool (for your own manufacture)
 Outil auxiliaire (fabrication locale)
 Utile (fabricación particular)

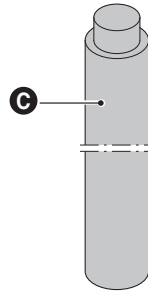
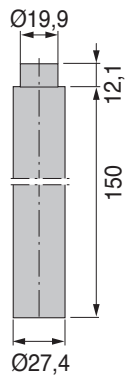

Montagedorn
 Mounting pin
 Arbre de montage
 Punzón de montaje

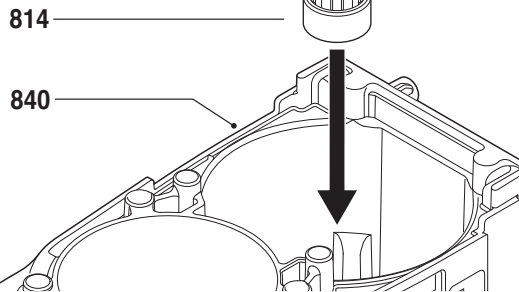

Montagedorn
 Mounting pin
 Arbre de montage
 Punzón de montaje

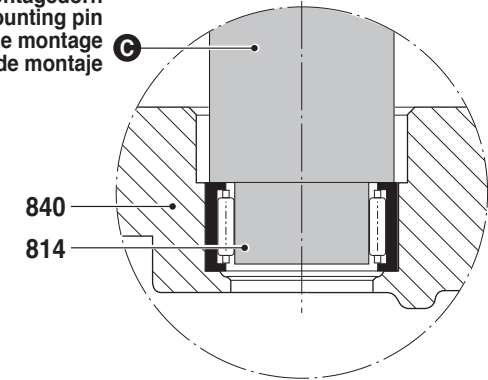

21.4

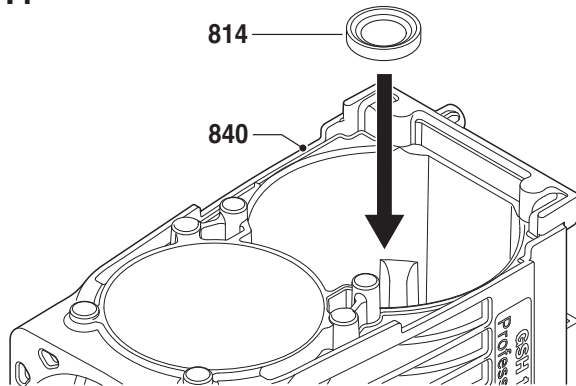

Montagedorn
 Mounting pin
 Arbre de montage
 Punzón de montaje

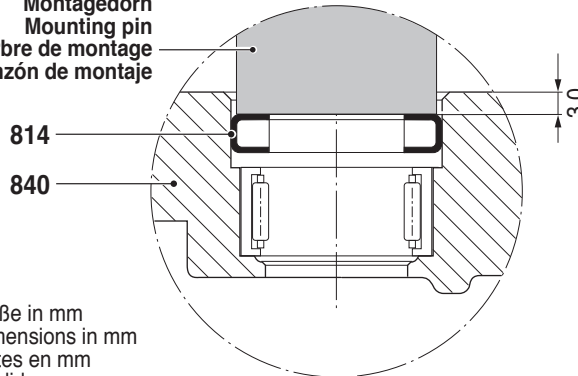

Maße in mm
 Dimensions in mm
 Cotes en mm
 Medidas en mm

21.5

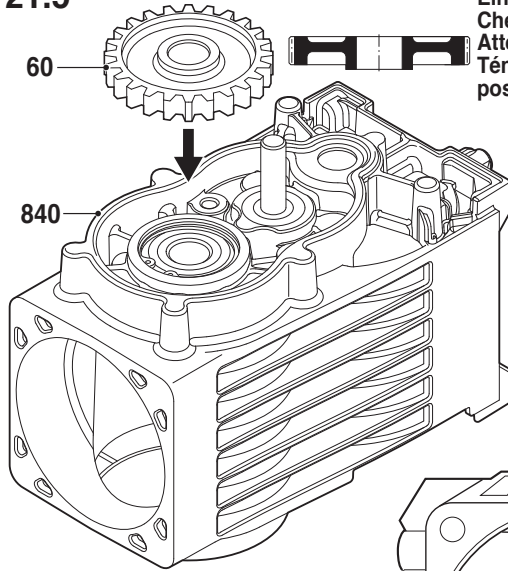

Einbauage beachten
Check installation position
Attention au positionnement
Téngase en cuenta la posición de montaje

72

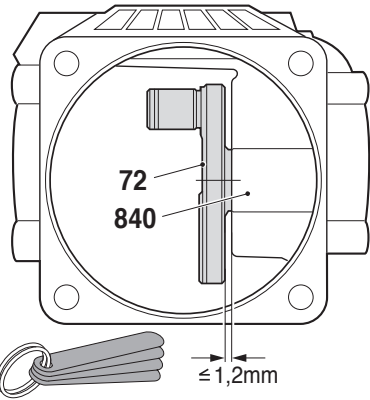

Spiel zwischen Pos.72 und Pos. 840
Play between pos.72 and pos. 840

≤ 1,2mm

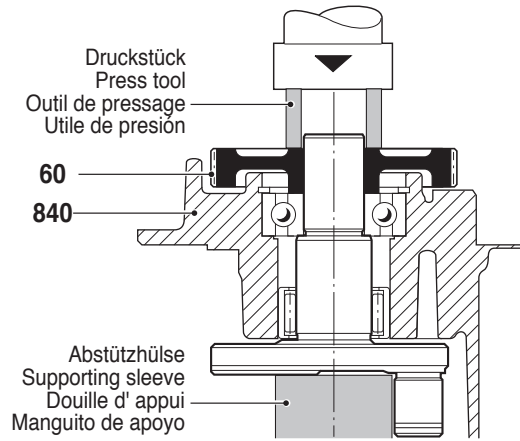

Druckstück
Press tool
Outil de pressage
Utile de presión

60
840

Abstützhülse
Supporting sleeve
Douille d'appui
Manguito de apoyo

22.

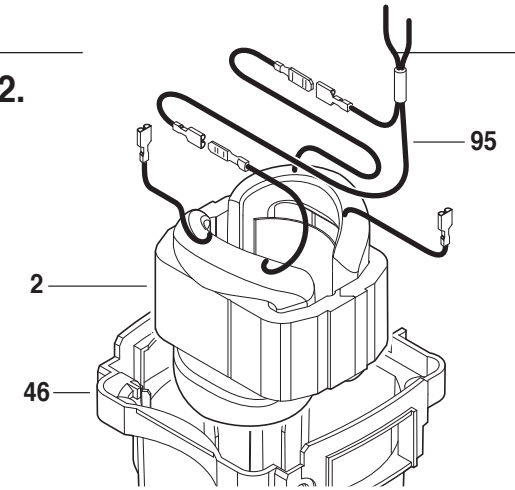

22.1

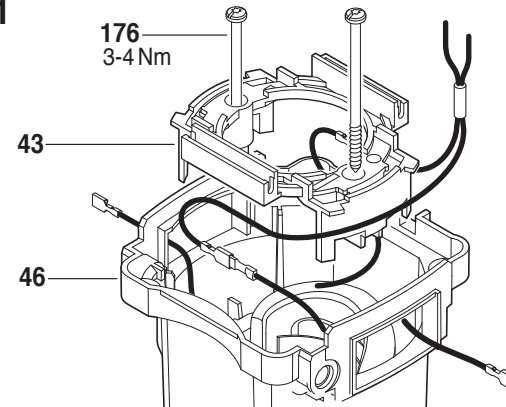

176
3-4 Nm

43

46

22.2

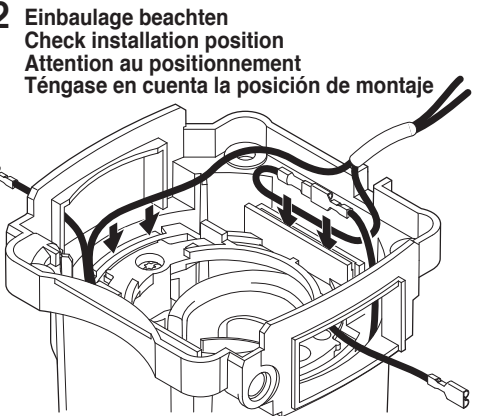

Einbauage beachten
Check installation position
Attention au positionnement
Téngase en cuenta la posición de montaje

22.3

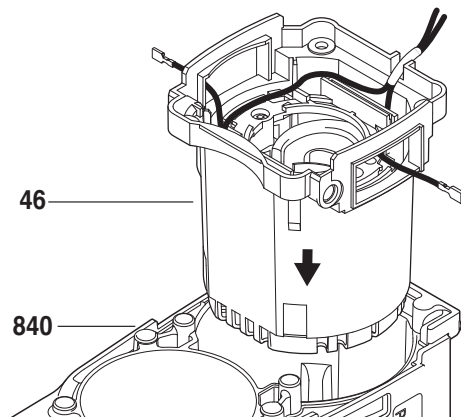

46

840

22.4

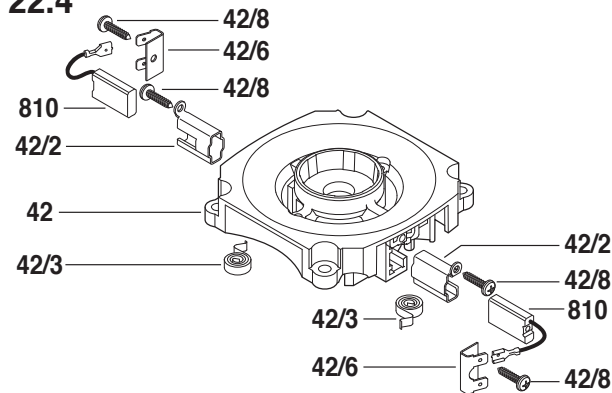

810

42/2

42

42/3

42/8

42/6

42/8

42/2

42/8

810

42/3

42/6

42/8

22.5

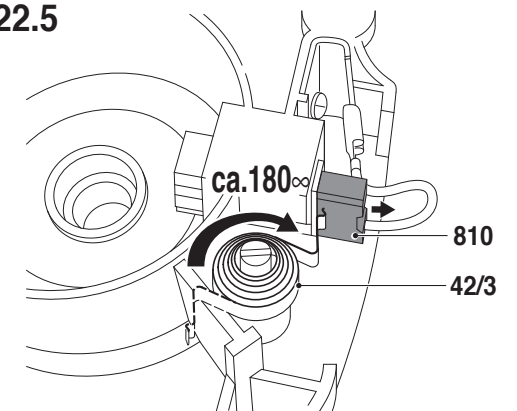

ca. 180

810

42/3

23.

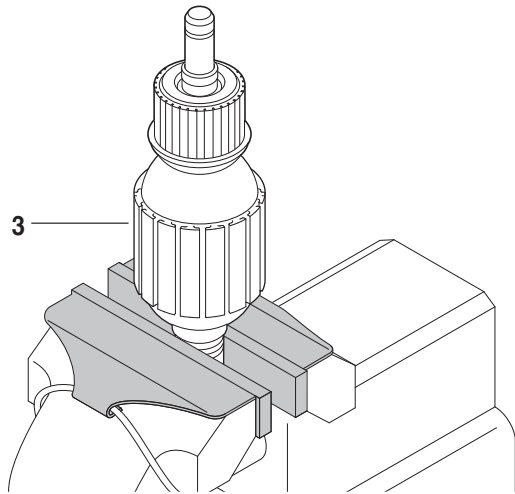

23.1

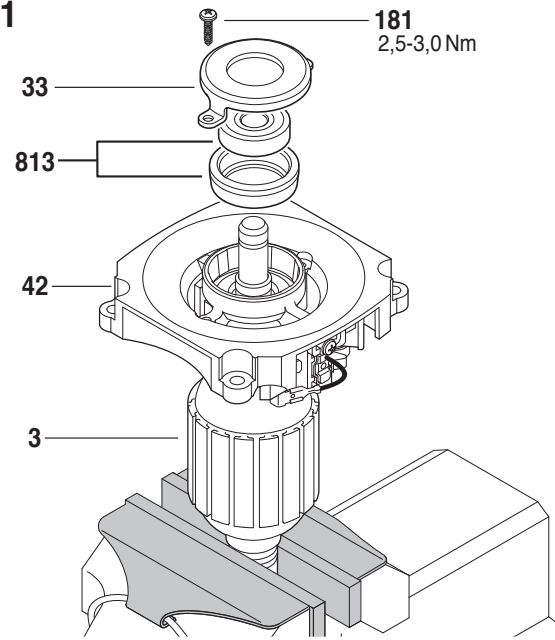

23.2

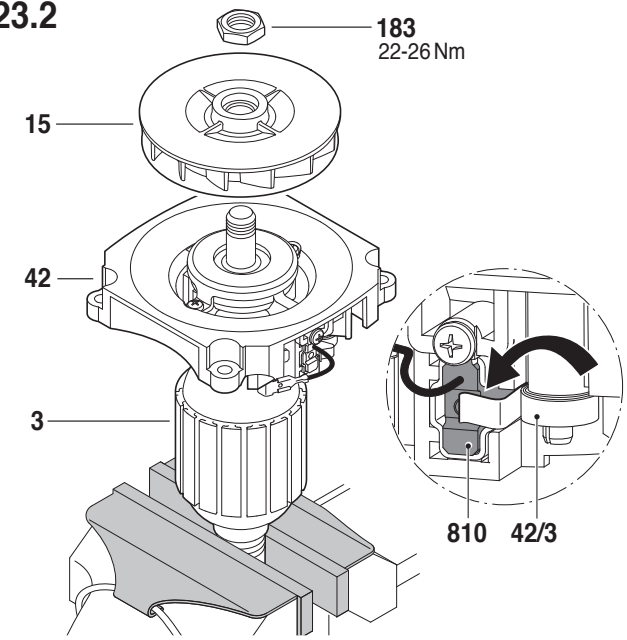

23.3

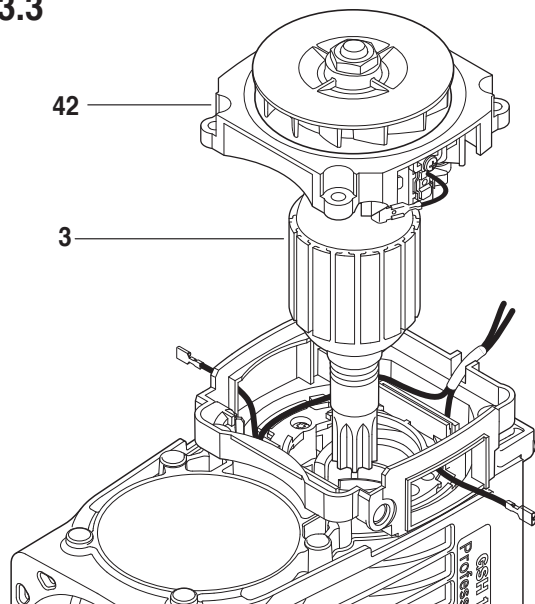

23.4

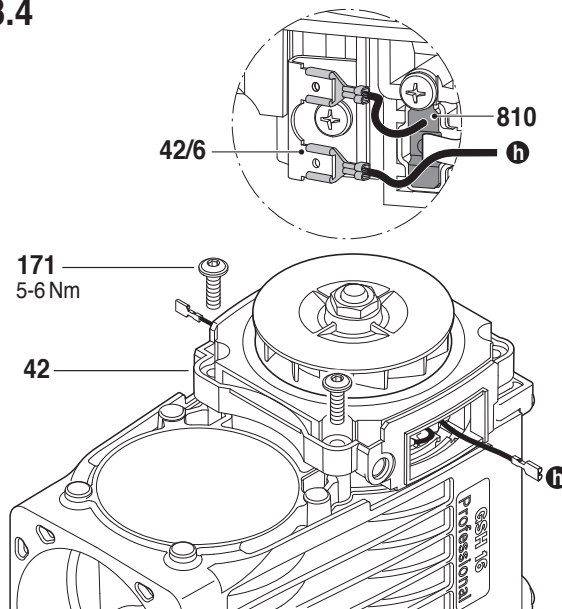

23.5

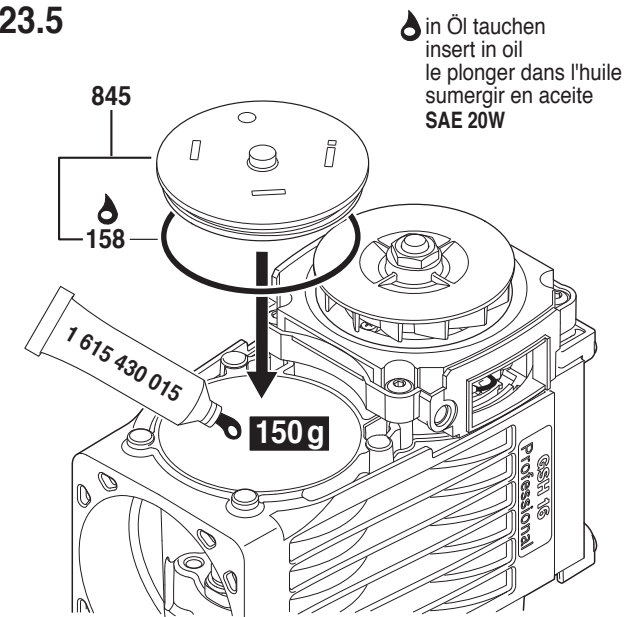

25.

★ mit Loctite 222 sichern
secure with Loctite 222

★171
5-6 Nm

★171
5-6 Nm

37

★172
5-6 Nm

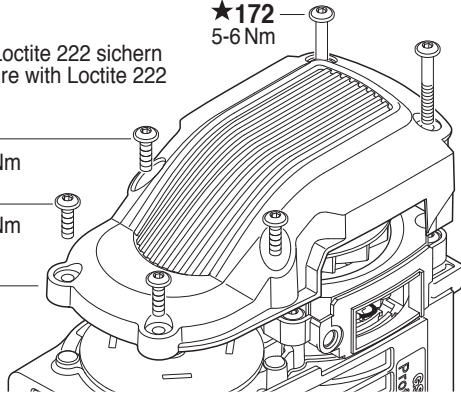

25.1

819
180
1,2-2,0 Nm

Einbaulage beachten
Check installation position
Attention au positionnement
Téngase en cuenta la posición
de montaje

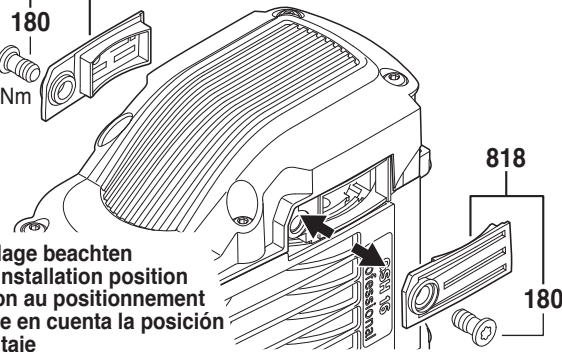

26.

119
118
119

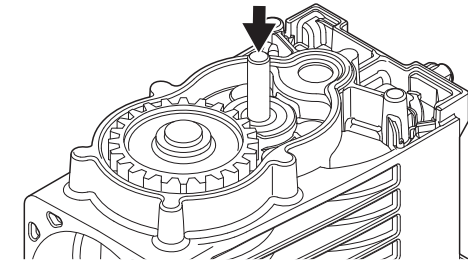

26.1

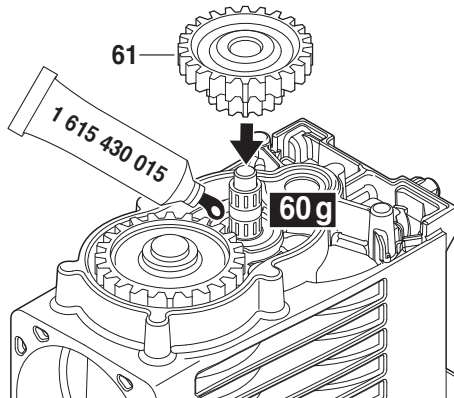

26.2

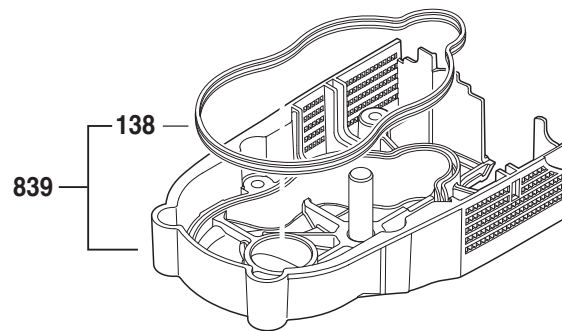

26.3

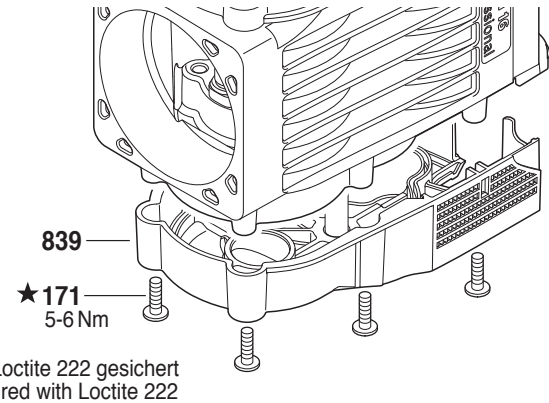

27.

in Öl tauchen
insert in oil
le plonger dans l'huile
sumergir en aceite
SAE 20W

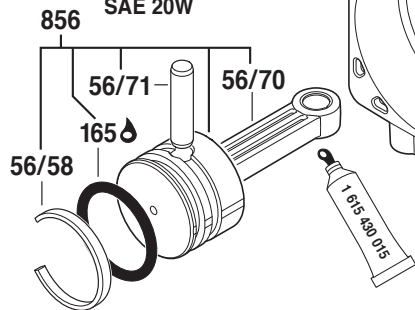

27.1

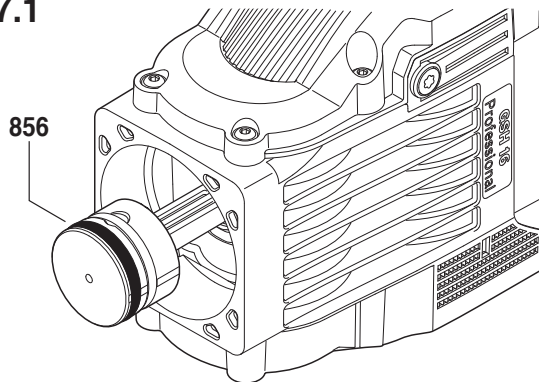

27.2

1 615 430 015
fetten
grease
graissees
engrasar

in Öl tauchen
insert in oil
le plonger dans l'huile
sumergir en aceite
SAE 20W

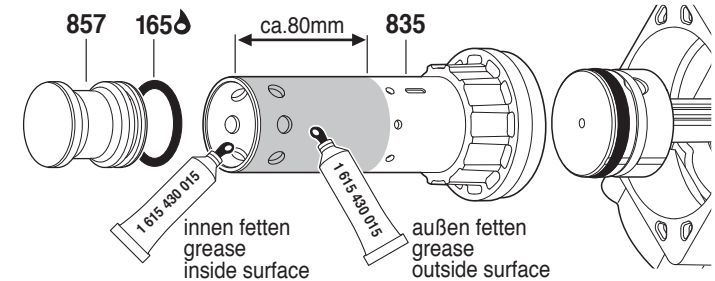

27.3

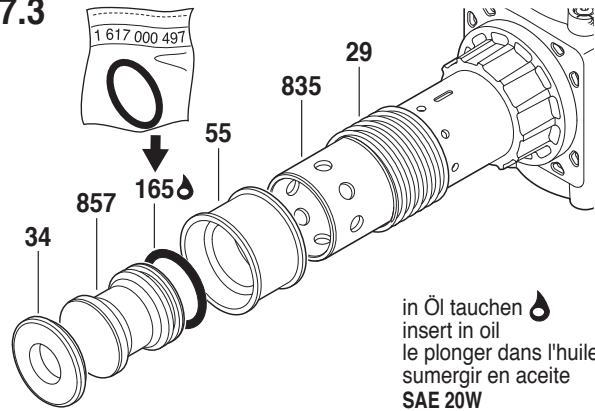

in Öl tauchen
insert in oil
le plonger dans l'huile
sumergir en aceite
SAE 20W

27.4

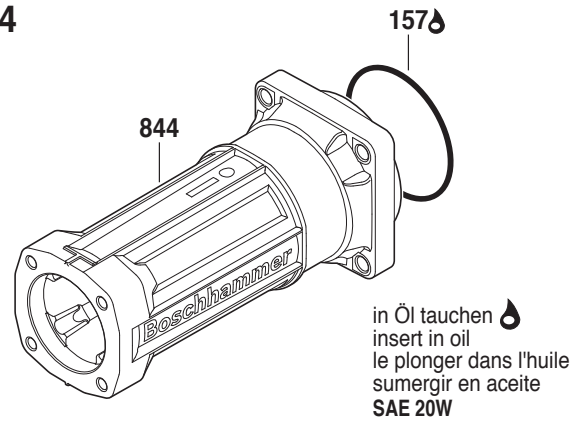

in Öl tauchen
insert in oil
le plonger dans l'huile
sumergir en aceite
SAE 20W

27.5

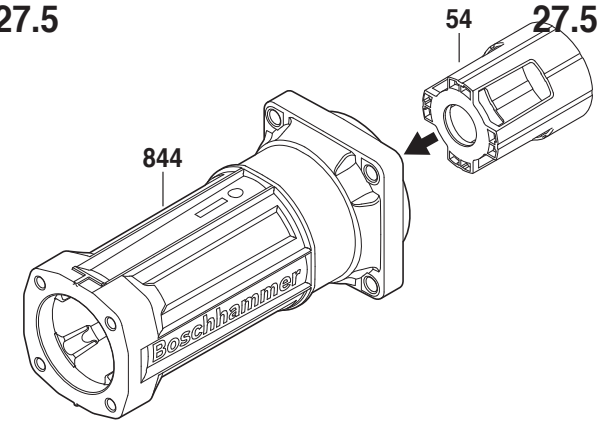

27.6

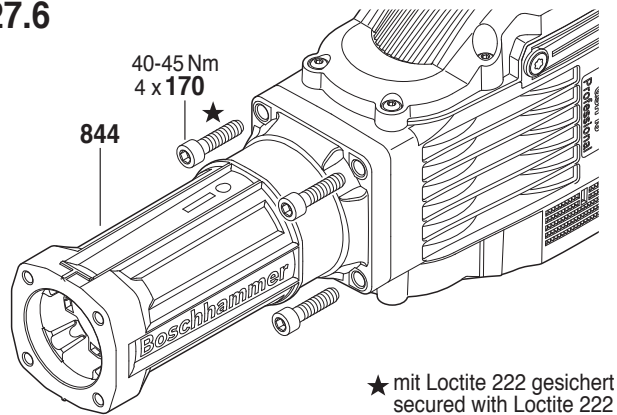

★ mit Loctite 222 gesichert
secured with Loctite 222

28.

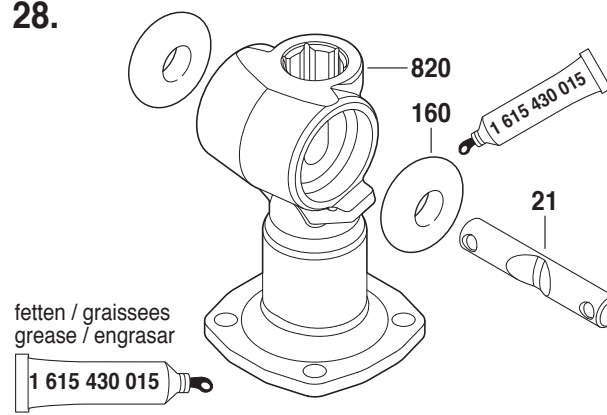

fetten / graissées
grease / engrasar

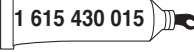

28.1

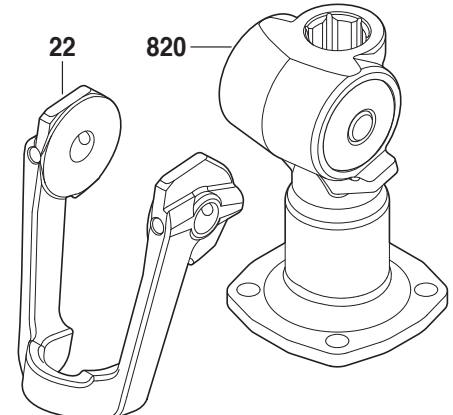

28.2

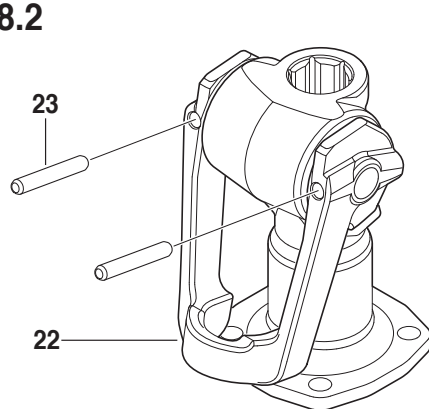

28.3

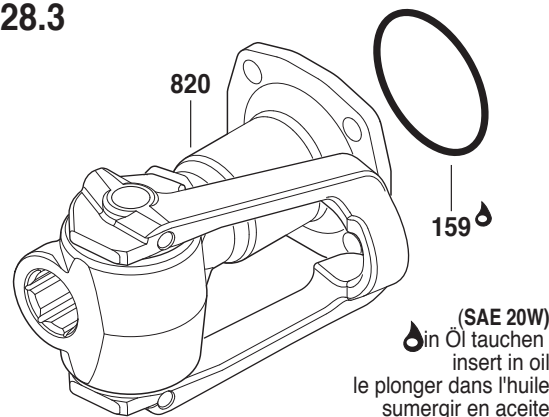

(SAE 20W)
in Öl tauchen
insert in oil
le plonger dans l'huile
sumergir en aceite

28.4

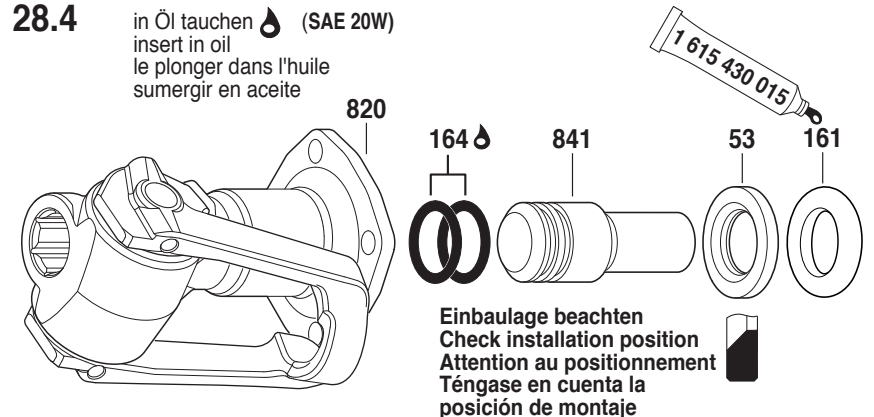

in Öl tauchen (SAE 20W)
insert in oil
le plonger dans l'huile
sumergir en aceite

Einbaulage beachten
Check installation position
Attention au positionnement
Téngase en cuenta la
posición de montaje

28.4

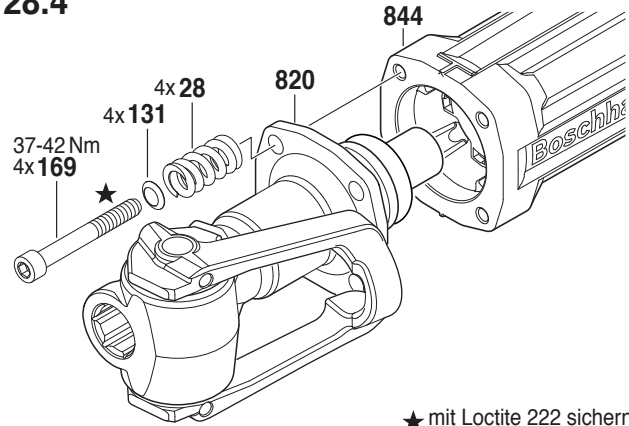

★ mit Loctite 222 sichern
secure with Loctite 222

28.5

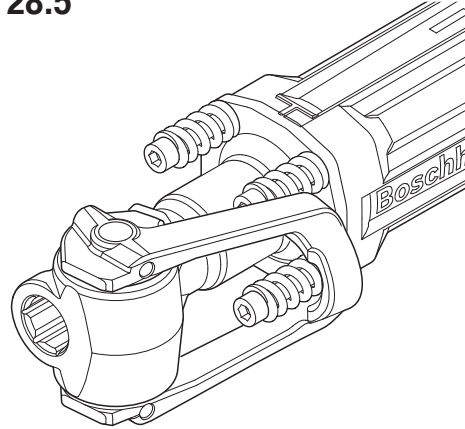

29.

Einbaulage beachten
Check installation position
Attention au positionnement
Téngase en cuenta la posición de montaje

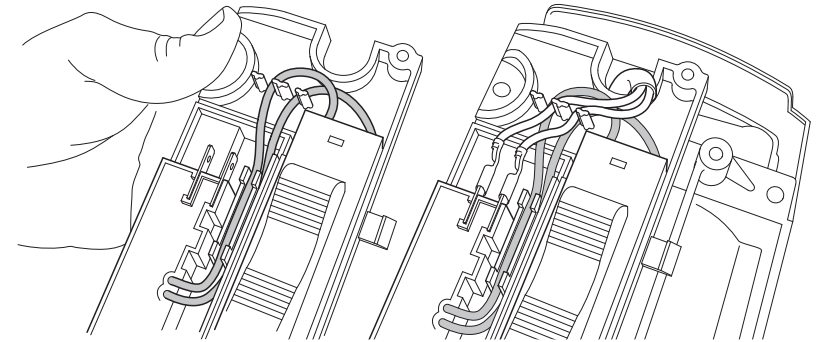

29.1

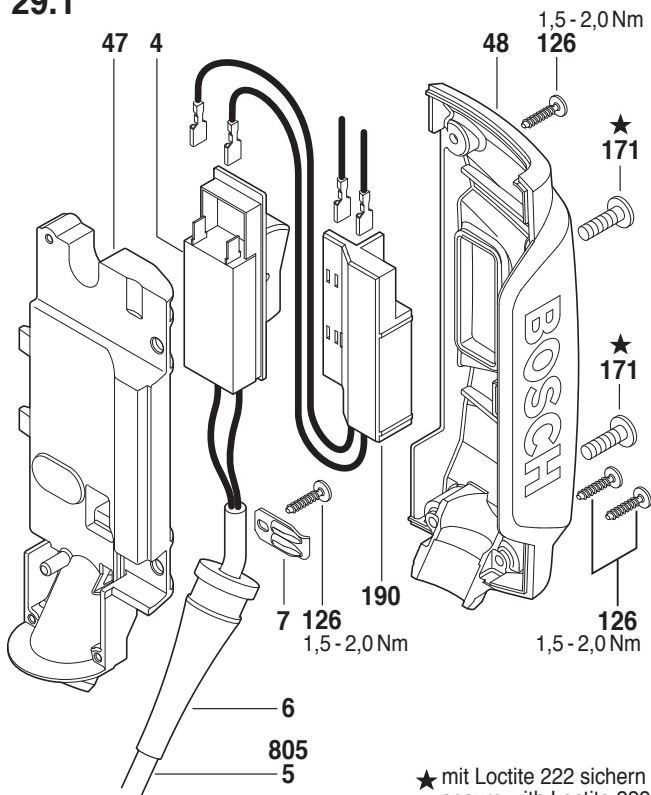

★ mit Loctite 222 sichern
secure with Loctite 222

29.2

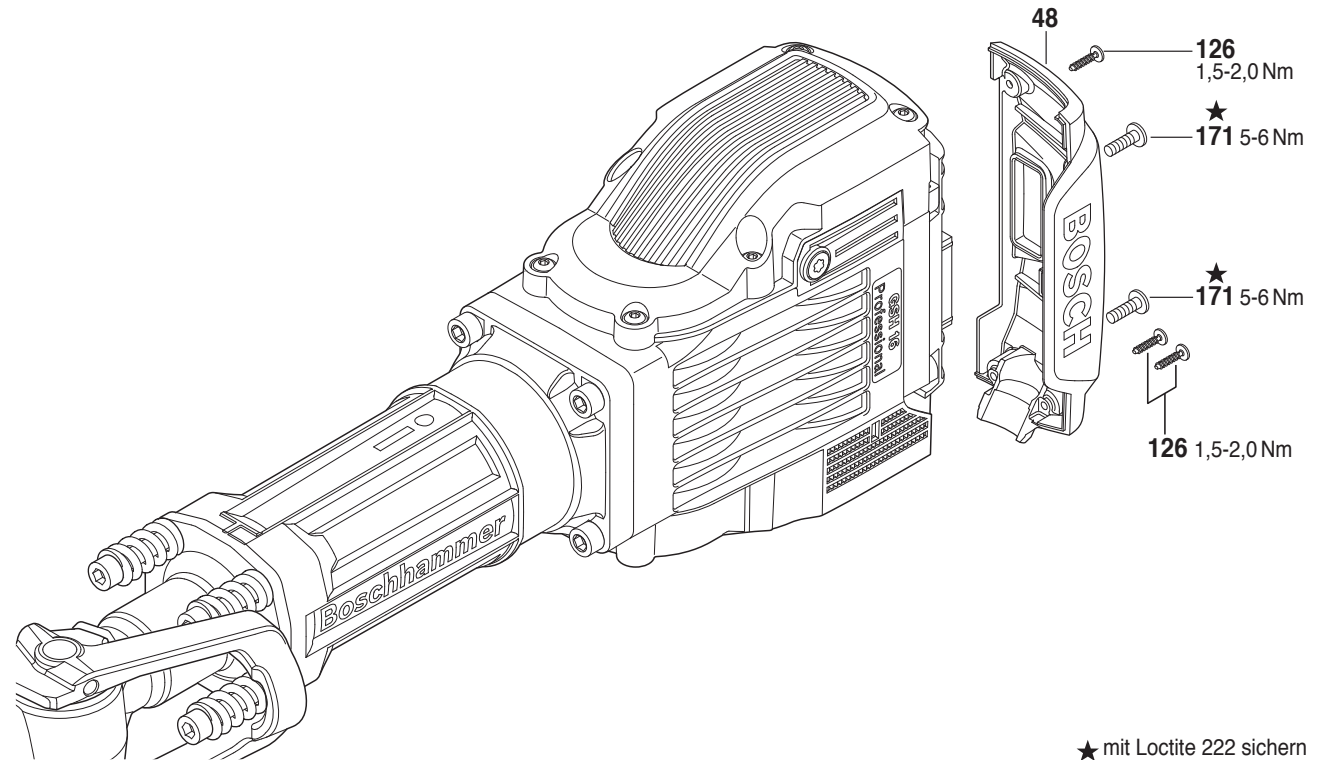

★ mit Loctite 222 sichern
secure with Loctite 222

30.

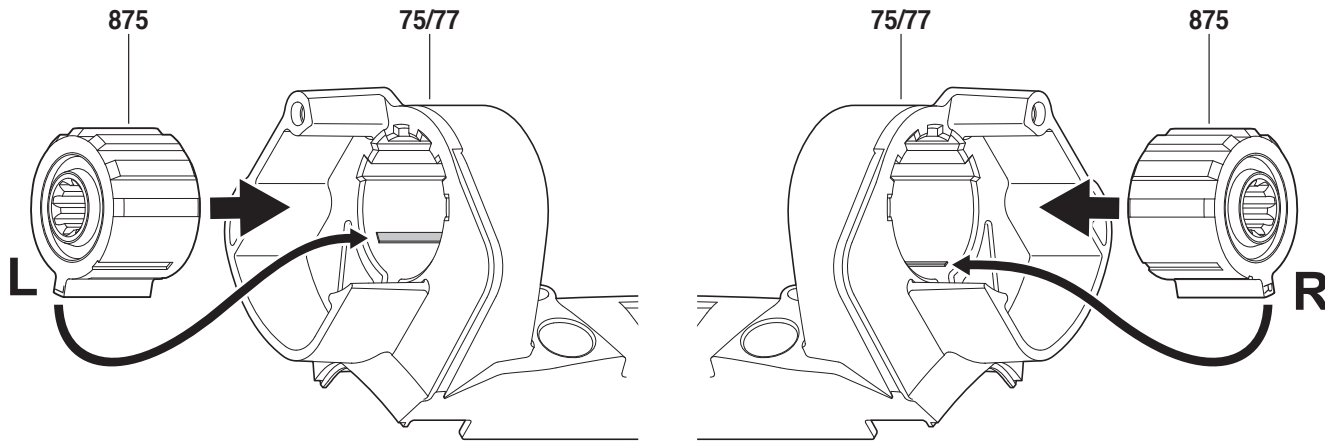

30.1

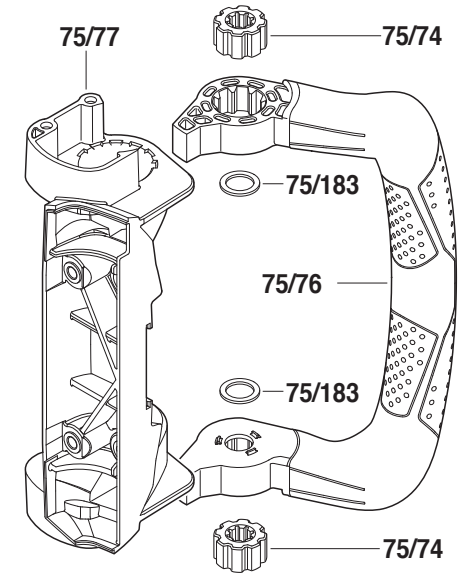

30.2

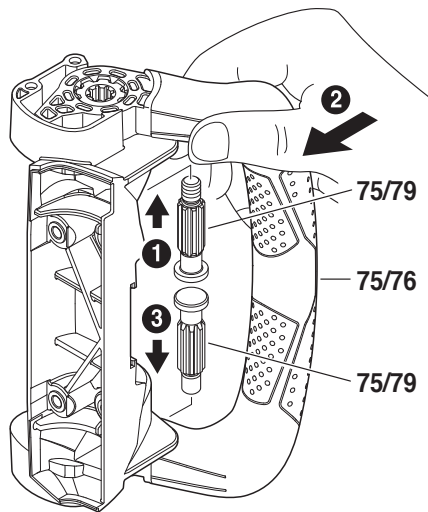

30.3

★ mit Loctite 222 sichern
secure with Loctite 222

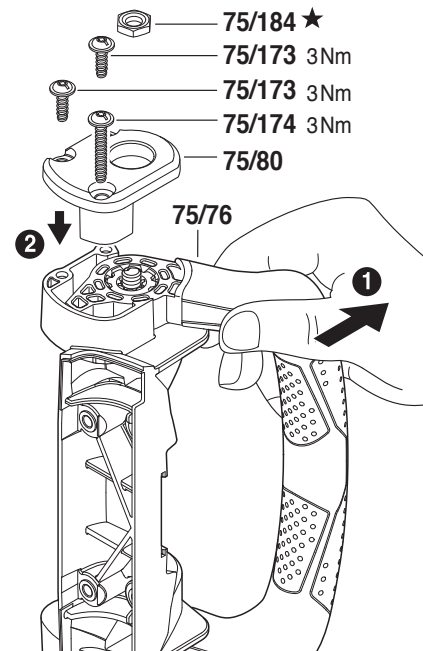

30.4

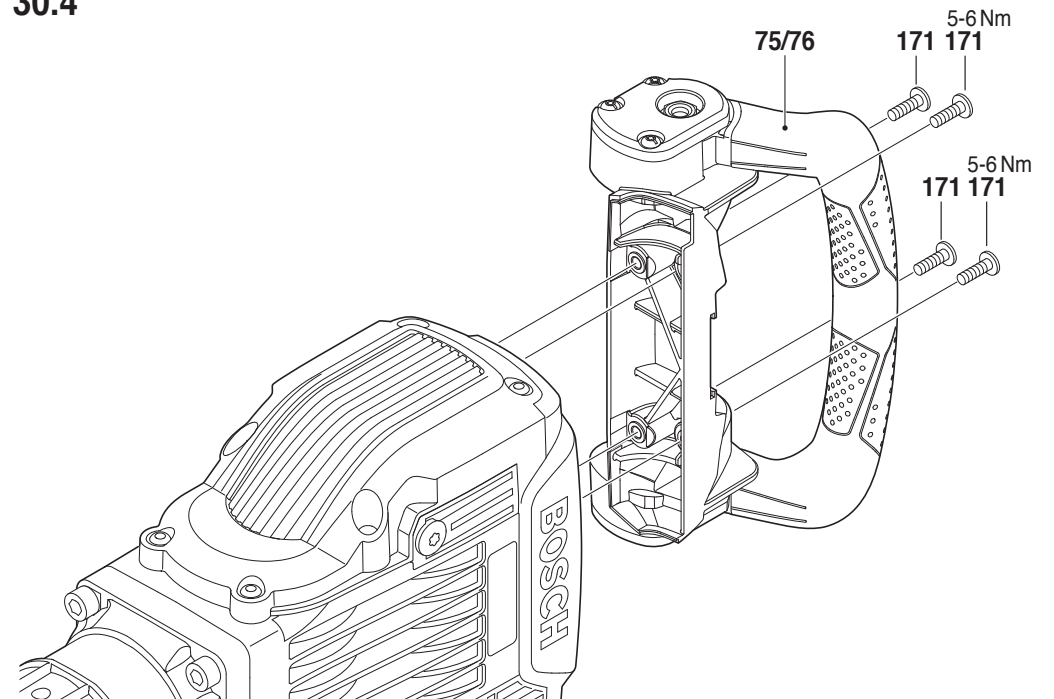

31.

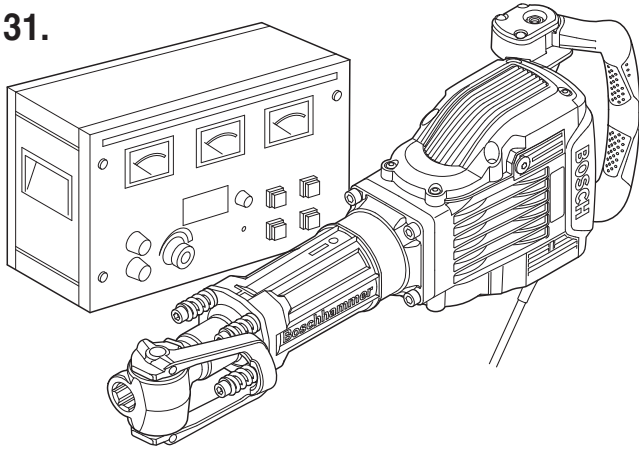

31. Hochspannungsprüfung durchführen.
Beachten:
Die Sicherheitsvorschriften nach DIN, VDE, CEE, AFNOR und weitere in den einzelnen Ländern gültigen Vorschriften sind einzuhalten.
31. Carry out power supply check.
Attention:
Safety regulations according to DIN, VDE, CEE, AFNOR and further regulations applicable in individual countries must be observed.

31. Effectuer un contrôle à haute tension.
Attention:
Respecter les instructions de sécurité selon DIN, VDE, CEE, AFNOR et les autres instructions valables dans les pays respectifs.
31. Efectuar la prueba de alta tensión.
Atención:
Atenerse a las prescripciones de seguridad según DIN, VDE, CEE, AFNOR y a las prescripciones adicionales específicas que pudieran existir en los respectivos países.

32.

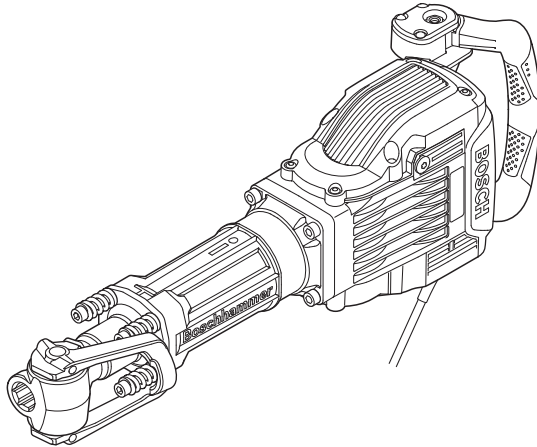

32. Probelauf, Schlagtest, elektrische und mechanische Prüfung durchführen.
32. Perform test run, impact test, electrical and mechanical check-up.

32. Marche à titre d'essai, contrôle de frappe et depercage, effectuer un contrôle mécanique et électrique.
32. Realizar un control funcional, una prueba de taladrado con y sin percusión y los ensayos eléctricos y mecánicos correspondientes.

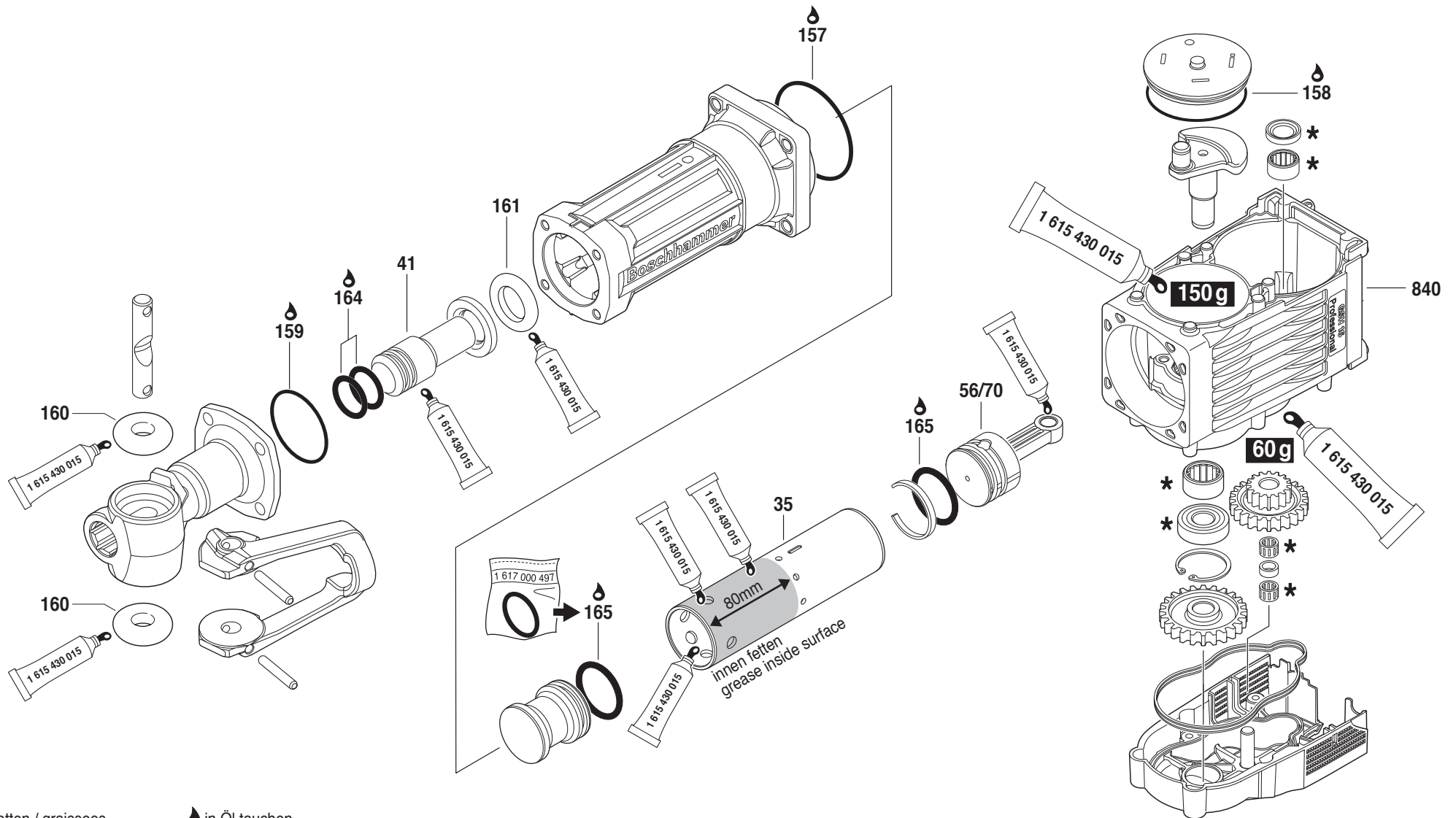

fetten / graissées
 grease / engrasar

in Öl tauchen
 insert in oil
 le plonger dans l'huile
 sumergir en aceite
SAE 20W

* wird gefettet geliefert
 pre greased delivered
 pré graissé livré
 pre engrasado ent regado

