

Опубликовано на сайте [www.rem-5.ru](http://www.rem-5.ru)

### Special Tools Require

- |                                      |              |
|--------------------------------------|--------------|
| ■ Torx screwdrivers sizes 15         | 4931 5990 04 |
| ■ Torx screwdrivers sizes 20         | 4931 5990 05 |
| ■ Forcing disks                      | 4931 5990 18 |
| ■ Mounting sleeve                    | 4931 5990 38 |
| ■ Mounting device                    | 4931 5990 39 |
| ■ Seeger circlip ring special pliers | 4931 5990 57 |
| ■ Special pliers                     | 4931 5990 79 |

### Important!

- Before maintenance carry out an introduction examination with high voltage check according to VDE (see chapter Electrical and Mechanical Test Instruction).
- Always disconnect the plug from the socket before carrying out any work on the machine.

## Disassembly

### Dismantling the FIXTEC-reception

- 1 Remove the locking ring (8).
- 2 Remove the locking sleeve (2); fix the locking sleeve in forcing disks and press it off (press with a suitable sleeve onto the spindle (1)).
- 3 To remove the balls (7) (6 pieces): depress the seal ring (4) and remove the balls with aid of a magnet.
- 4 Remove the remaining parts:
  - locking ring (4)
  - spring (5)
  - washer (6)

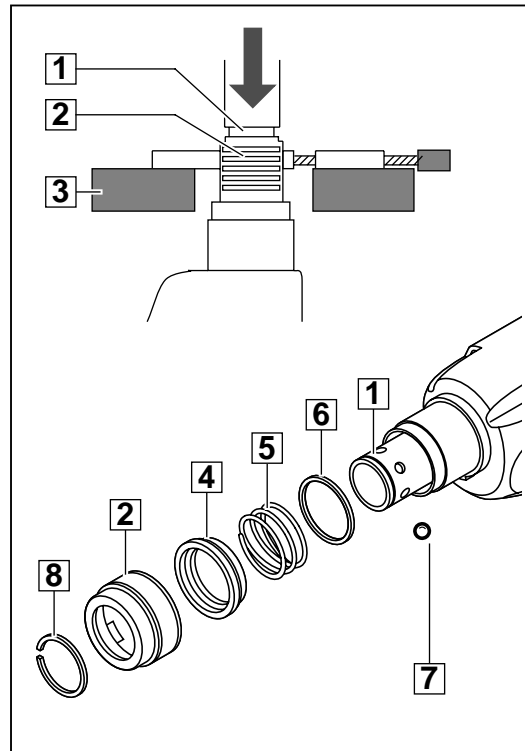

**1**

### Removing the gear housing

- 1 Fix the machine in a mounting stand.
- 2 Undo the four housing screws (1).
- 3 Remove the locking ring (3): force apart the locking ring on the spindle with aid of special pliers (4931 5990 57), lift the gear housing (2), press the ring from the groove and pull it off.
- 4 Turn the switch lever (4) to the "Hammer" position.
- 5 Lift the gear housing (2) approx. 1 cm.
- 6 Slowly remove the gear housing (2) and at the same time slowly turn the switch lever (4) to the "Drilling" position.
  - ☞ Do not apply any force since parts could get damaged.

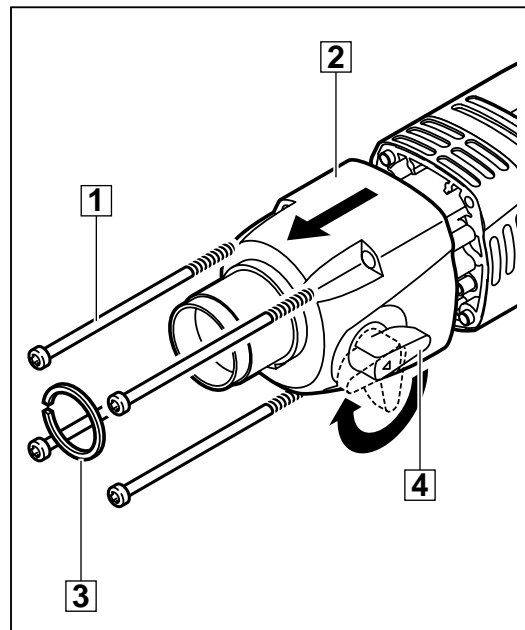

**2**

### Removing the switch lever

- 1 Pull the clamp (1) from the gear housing and remove the switch lever (3) with the O-ring (2).

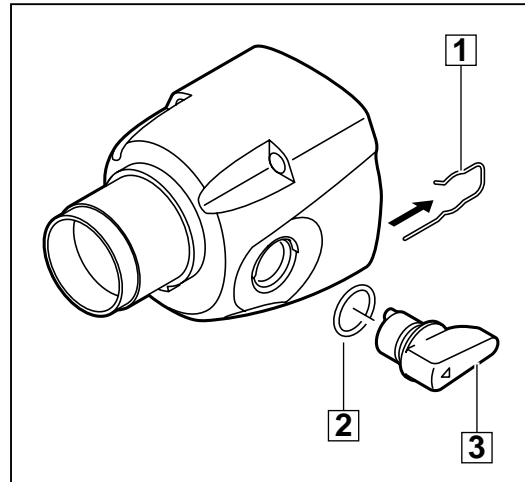

**3**

### Detaching the spindle

- 1 Undo the four screws (1). (Screws are mounted with locking device!)
- 2 Remove two disks (2).
- 3 Pull off the spindle (3).
- 4 Remove the cylinder (6).
- 5 Remove two disks (5).
- 6 Press out the bolt (4) manually.

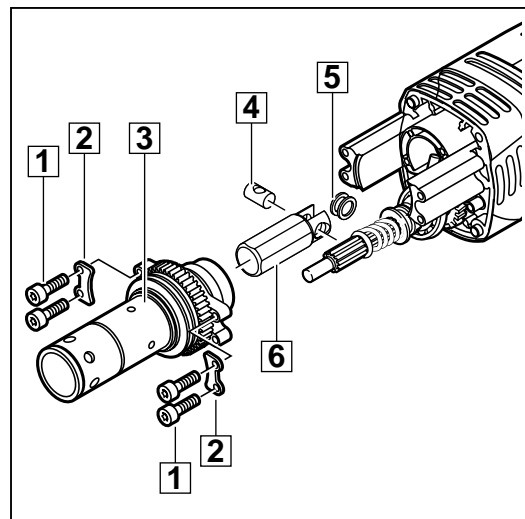

**4**

### Dismantling the spindle (detaching the outer parts)

- 1 Remove the percussion body (D) from the spindle (1).
- 2 Remove the Seeger circlip ring (C) with aid of the pliers.
- 3 Remove the damper ring (B).
- 4 Remove the holder (A).
- 5 Remove the washer (9).
- 6 Remove the locking ring (8): press the spindle wheel (6) with a sleeve against the spring disks (5) – the locking ring (8) is released and can be removed with aid of pliers.
- 7 Remove the coupling disk (7) with the respective three bolts.
- 8 Remove the spindle wheel (6).
- 9 Remove three balls (2).
- 10 Remove the spring disks (5), the washer (4) and the ring (3).

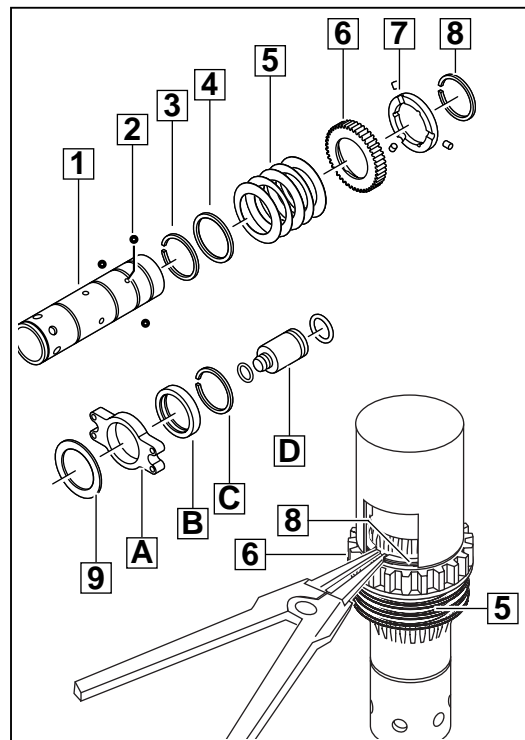

**5**

### Dismantling the spindle (removing the inner locking ring)

- 1 Insert two or, if necessary three screwdrivers into the service borings and lever off the locking ring (1) from the groove.
- 2 Press out the locking ring (1) from the opposite side.

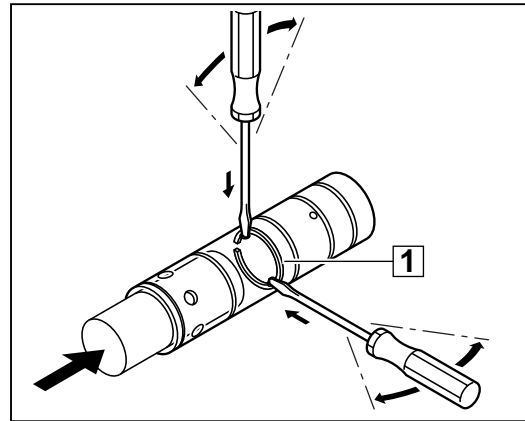

**6**

### Dismantling the spindle (inner parts)

- 1 Press the following parts from the spindle (1):
  - washer (8)
  - pressure sleeve (6)
  - plunger (4)
  - sleeve (2) (is pressed in)
- 2 Remove the O-rings (7), (5) and (3).

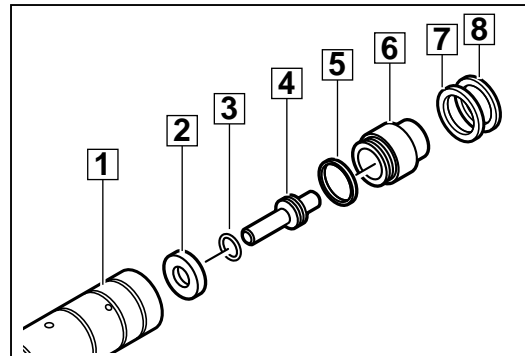

**7**

### Dismantling the bearing end plate

- 1 Remove the bearing end plate.
  - Take care that the armature stays in the motor housing.
- 2 Remove the bearing end plate insulation (5).
- 3 Loosen the two screws (8).
- 4 Remove the plate (9), the bearing cover (7) and the O-ring (A).
- 5 Undo the screw (6).
  - The screw is glued in. The screwdriver must fit exactly to remove the screw (or the screw head might get damaged). 2.5 mm inner hexagon. Only use a short screwdriver bit.
- 6 Remove the reduction gear (C).
- 7 Remove the gasket (1).
- 8 Remove the seal ring (4) and the needle bearing (3).
- 9 Remove the ball bearing (B).

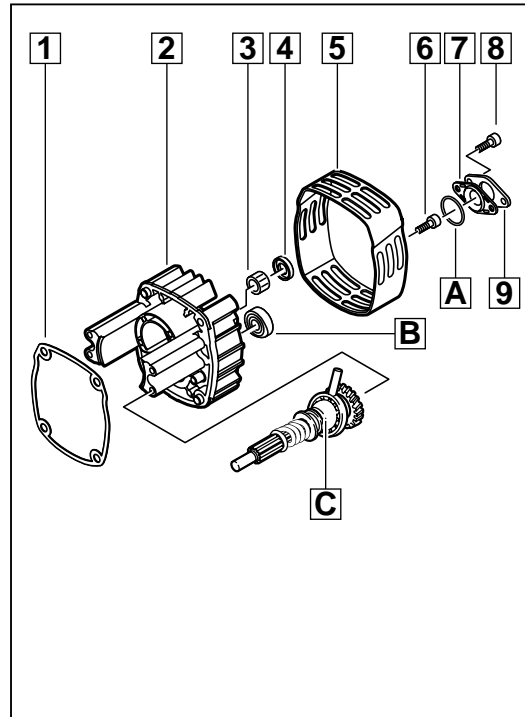

**8**

### Dismantling the back gear shaft

- 1** Remove the locking ring (6).  
(Attention difficult!)
- 2** Press off the back gear wheel (5).
- 3** Remove the remaining parts from the back gear shaft (1):
  - tumble drive (4)
  - coupling box (3)
  - spring (2)

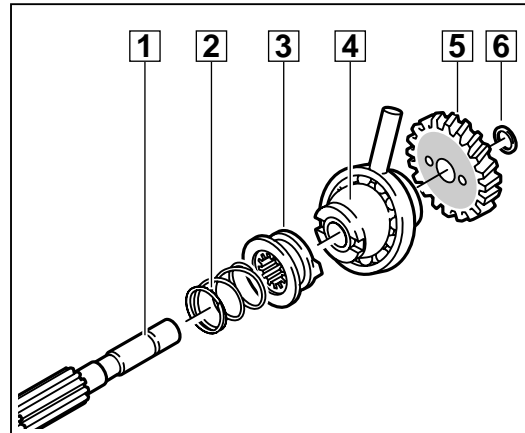

**9**

### Dismantling the handle

- 1** Place the machine on its left side.
- 2** Undo the screw (3) and lever off the Softgrip (4) on its two lugs (5).
- 3** Loosen the remaining screws (8) and remove the housing half (6).
- 4** Remove the motor (9) completely with the switch (A) and the mains connection sleeve (B).
- 5** Remove the holding down device (2).
- 6** Remove the plastic disk (7).

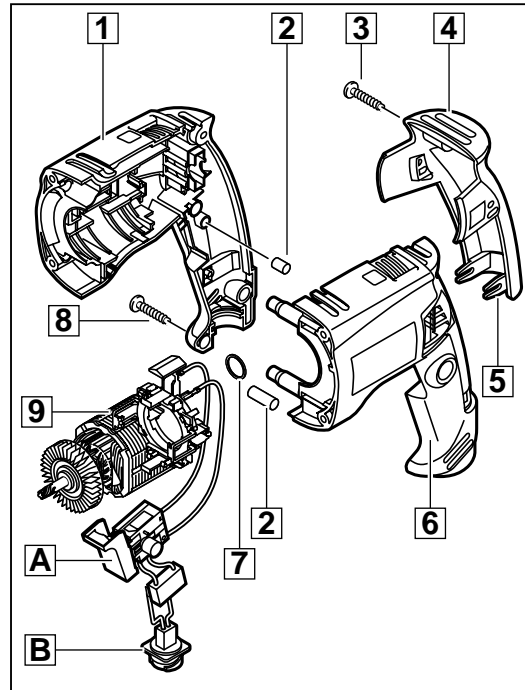

**10**

### Detaching the change-over switch for reversible operation

- 1** Pull the switch lines (5) from the field (4).
  - 2** Turn the switch unit (1) to the middle position.
  - 3** Carefully bend the plastic lug (2) with a screwdriver and pull out the carbon brush holders (3) together with the carbon brushes.
-  Attention! The plastic lugs break easily.
- 4** Slightly bend the holders with the special pliers (6) (4931 5990 79) and remove the change-over unit (1) from the field.

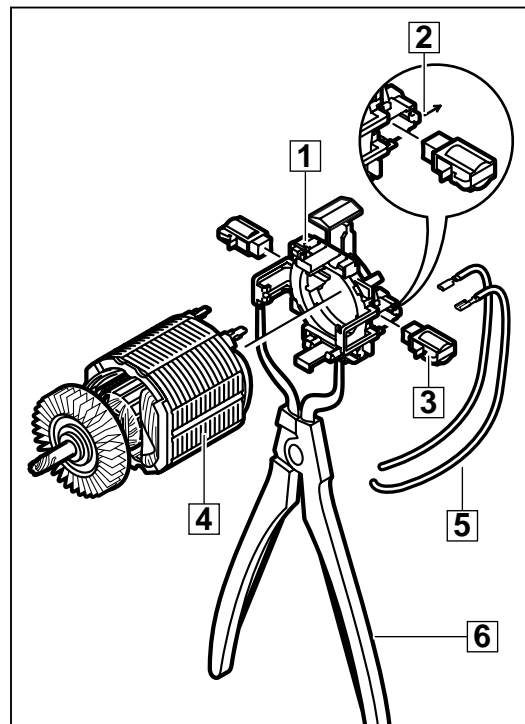

**11**

**Removing  
the armature**

- 1** Pull the armature (1) from the field (5).
- 2** Pull off the rubber cap (3).
- 3** Lever off the locking ring (4).
- 4** Remove the bearing (2).

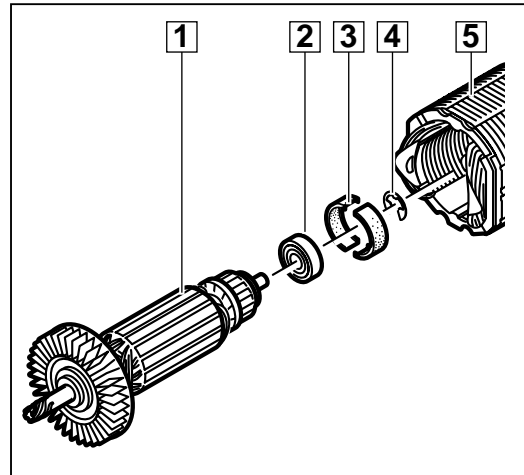
**12****Detaching  
the switch**

- 1** Unscrew the connecting lines of the mains connection sleeve (4) from the switch (1).
- 2** Unplug the cables (2) and the capacitor (3).

 To loosen the cables, push an awl or a piece of bent wire through the opening above the cable, depress the cable clamp, and pull out the cable (see enlarged illustration).

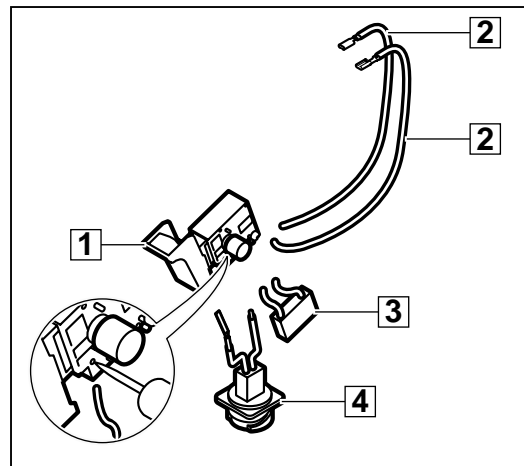
**13**

## Maintenance

<b>Cleaning</b>	Clean all parts – with the exception of the electrical parts – with cold cleaning agent. <b>Caution!</b> No cleaning agent should penetrate into the bearing. Clean the electrical parts with a dry brush.
<b>Check for wear</b>	Check the disassembled parts for wear (visual inspection) and replace worn parts.
<b>Electrical tests</b>	Before reassembling, perform an electrical test on all relevant parts (see chapter Electrical and Mechanical Test Instructions).
<b>Lubrication</b>	Each time maintenance is performed, the machine is to be lubricated as stated in the lubrication plan. After the machine is fully disassembled, completely remove the old grease and replace with new grease. The grease must be applied to the machine as indicated in the lubrication plan.

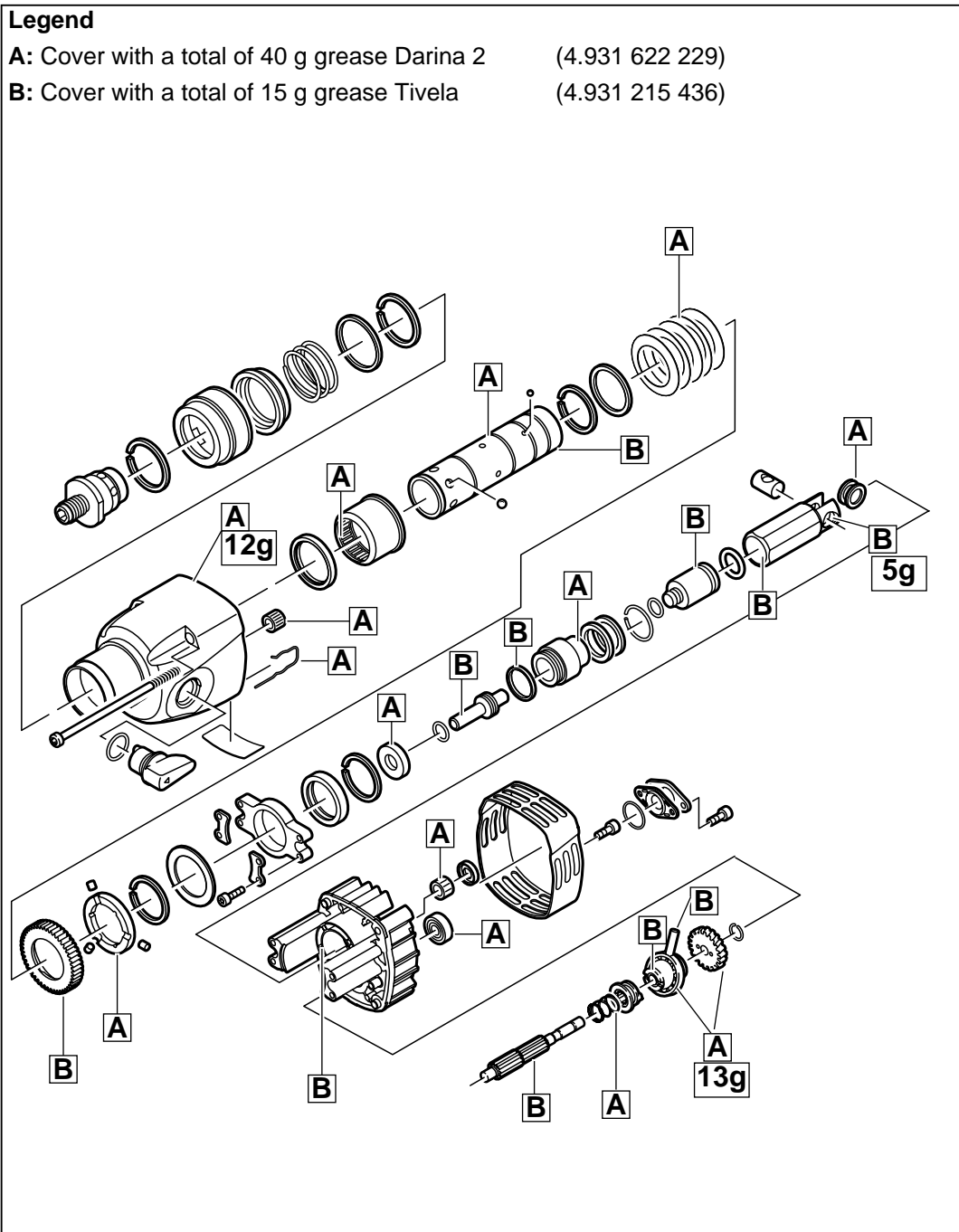

<b>Torques</b>	Housing screws in plastic	1.5 Nm
	Holding down screws gear housing	2.0 Nm
	Screws in metal	2.5 Nm

### Assembly

#### Mounting the switch

- 1 Insert the cables (2) and the capacitor (3) into the switch (1) according to the wiring diagram.
- 2 Screw down the connecting lines of the mains connection sleeve (4) to the switch (1).

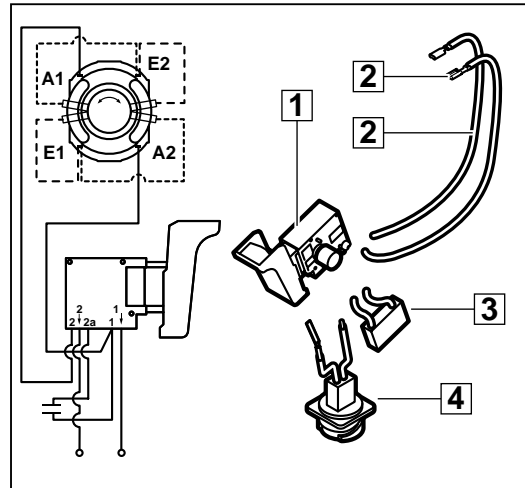

**1**

#### Mounting the armature

- 1 Push the bearing (2) over the armature shaft.
- 2 Mount the locking ring (4).
- 3 Fit the rubber cap (3) to the bearing.
- 4 Insert the armature (1) into the field (5).

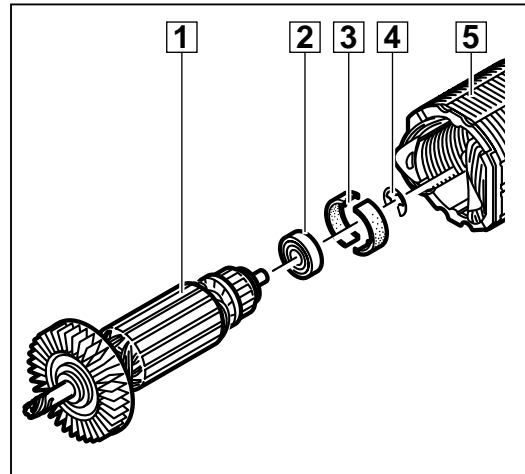

**2**

#### Mounting the change-over switch for reversible operation

- 1 Slightly bend the holders with special pliers (5) (4931 5990 79), fit the change-over unit (2) to the field (6) and let it engage.
  - Take care that the lugs (1) engage.
- 2 Insert the carbon brush holders (4) together with the carbon brushes.
  - Take care that the plastic lugs (3) engage in the carbon brush holder (4).
- 3 Fix the switch lines (7) on the field (6).

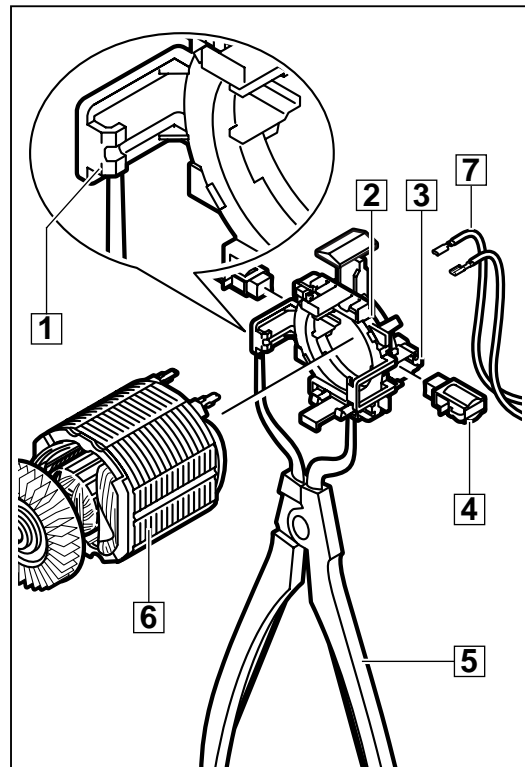

**3**



### Assembling the handle

- 1 Insert the plastic disk (7) into the right housing half (1).
- 2 Insert the holding down device (2).
- 3 Insert the motor (9) completely with the switch (A) and the mains connection sleeve (B).
- 4 Fit the other half of the housing (6) and fasten the screws (8).
- 5 Fit the softgrip (4) and fasten the screw (3).

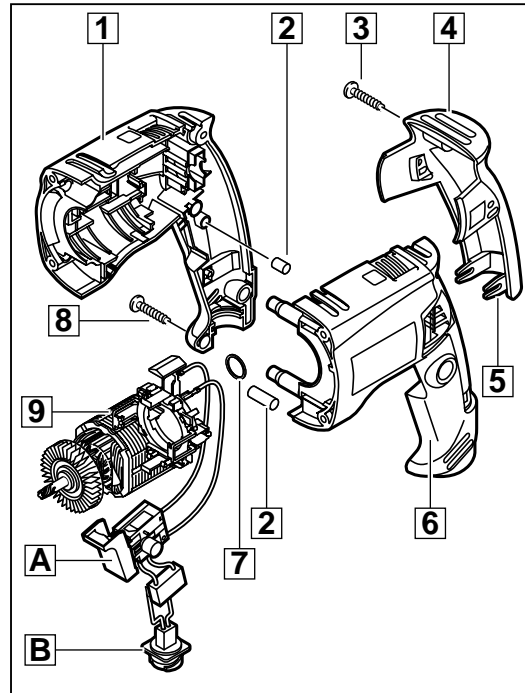

### Assembling the back gear shaft

- 1 Push the spring (2), the coupling sleeve (3), and the tumble drive (4) over the reduction gear shaft (1).
- 2 Press on the gear wheel (5) with a distance of 0.05 mm to the tumble drive (4) (illustration A). The smooth surface must face the tumble drive (4).
- 3 Insert the locking ring (6).

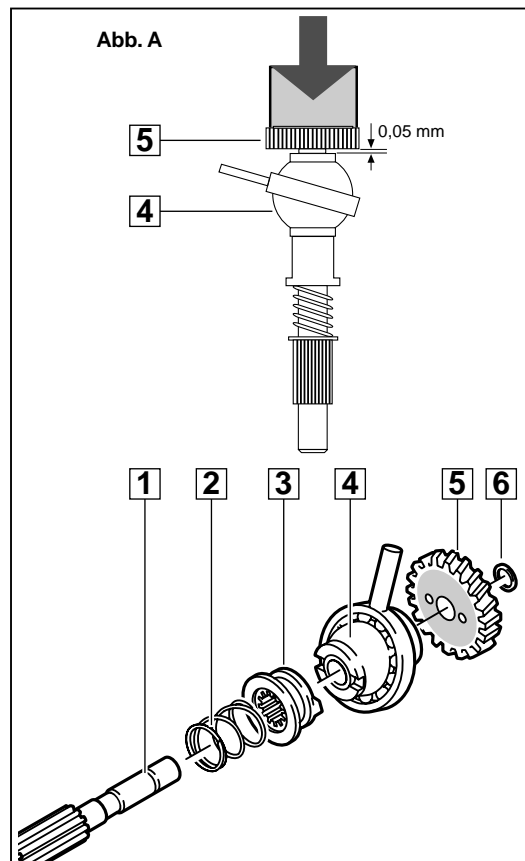

### Mounting the bearing end plate

- 1** Fix the machine in the mounting stand.
- 2** Mount the ball bearing (B).
- 3** Insert the needle bearing (3) and the seal ring (4).
- 4** Insert the gasket (1).
- 5** Insert the reduction gear (C).
- 6** Apply Loctite 222 or Omnifit 80 to the screw (6) and fasten it (2.5 Nm).  
 The screwdriver must fit exactly to fasten the screw (or the screw head might get damaged). 2.5 mm inner hexagon. Only use a short screwdriver bit.
- 7** Insert the O-ring (A), the bearing cover (7) and the plate (9).
- 8** Cover two screws (8) with Loctite 222 or Omnifit 80 and fasten them.
- 9** Fit the bearing end plate insulation (5).
- 10** Mount the bearing end plate.

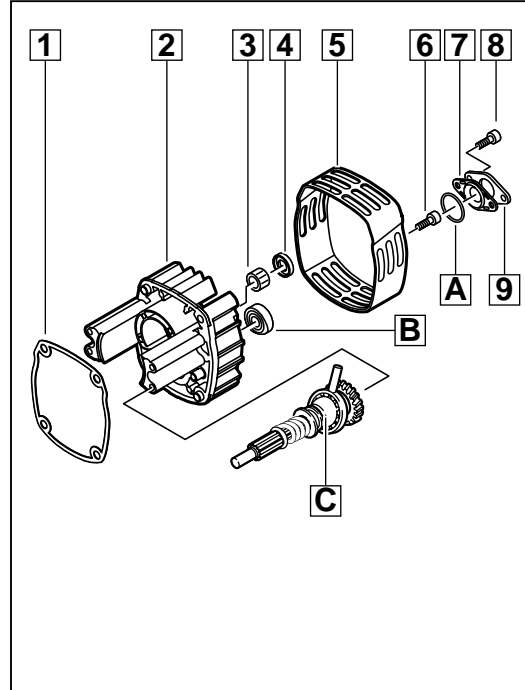

**6**

### Assembling the spindle (mounting the inner parts)

- 1** Insert the following parts into the spindle (1):
  - sleeve (2) (press in)
  - o-ring (3)
  - snap die (4)
  - o-ring (5)
  - pressure sleeve (6)
  - o-ring (7)
  - disk (8)
- 2** Insert the locking ring (9) into the spindle (1) with aid of a used cylinder (A) until the locking ring engages. Half of the boring must be covered.

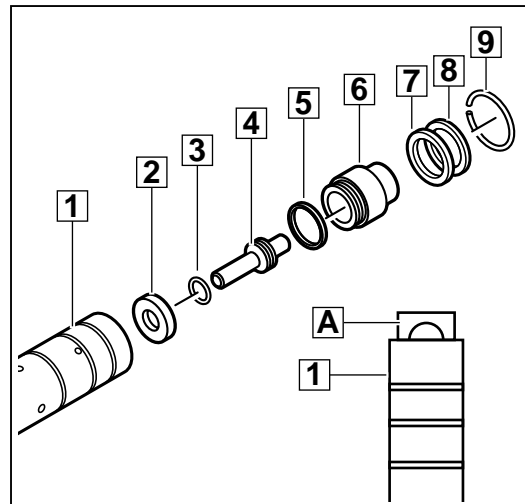

**7**

### Mounting the spindle (outer parts)

- 1** Push the following parts over the spindle (1):
  - ring (2)
  - disk (3)
  - spring disks (4)
  - spindle wheel (5)
  - coupling disk (6) with the respective three bolts
  - locking ring (7)
  - disk (8)
  - holder (9) with the smooth side facing the spindle (1)
  - damper ring (A)
  - seeger circlip ring (B)
- 2** Insert the percussion body (C) into the spindle (1).

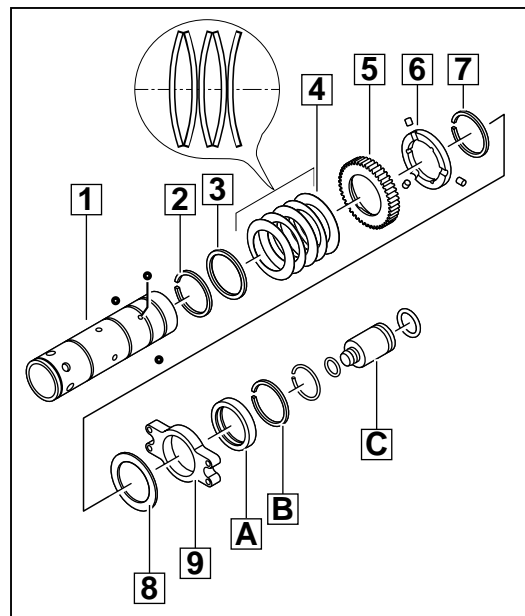

**8**

### Mounting the spindle

- 1 Insert the cylinder (6) with the two disks (5) and the bolts (4) into the wobble gear.

 The wobble gear must be in upper position. Take care that the pin of the wobble gear grasps the boring of the bolt (4).

- 2 Insert the spindle (3) into the bearing end plate.
- 3 Fit two plates (2).
- 4 Cover four screws (1) with Loctite 222 or Omnifit 80 and fasten them (2.5 Nm).

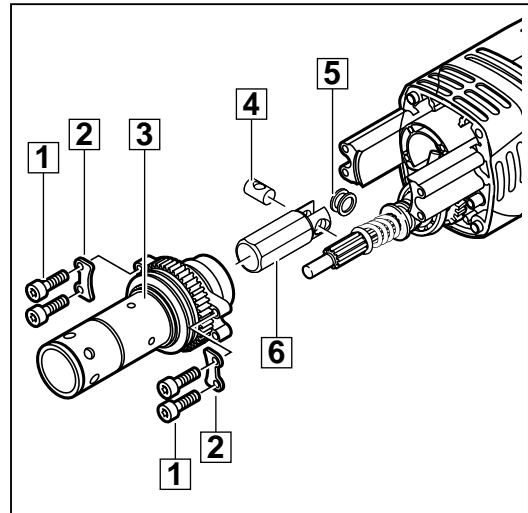

**9**

### Mounting the switch lever

- 1 Insert the switch lever (3) with the O-ring (2).
- 2 Push in the clamp (1).

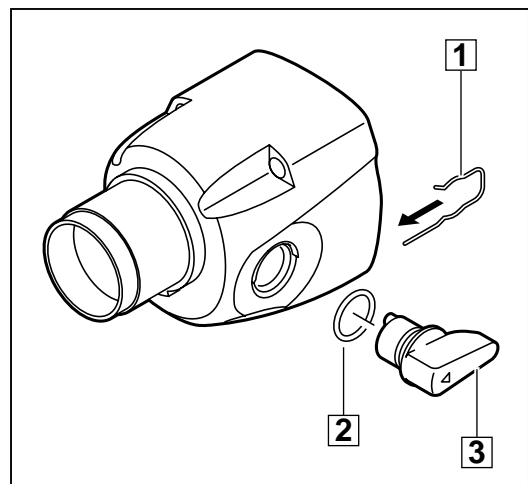

**10**

### Mounting the gear housing

- 1 Insert the sleeve (1) (with service tool 4931 5990 38) into the gear housing (2) (the sleeve protects the rotary shaft seal in the gear housing from damage during mounting).
- 2 Turn the switch lever (5) to the "Drilling" position.
- 3 Push the gear housing (2) slowly over the machine. At the same time slowly turn the switch lever (5) to the "Hammer" direction.
 

 Do not use any force since parts might get damaged.
- 4 Screw down the four housing screws (4) (2 Nm).
- 5 Press in the locking ring (3).

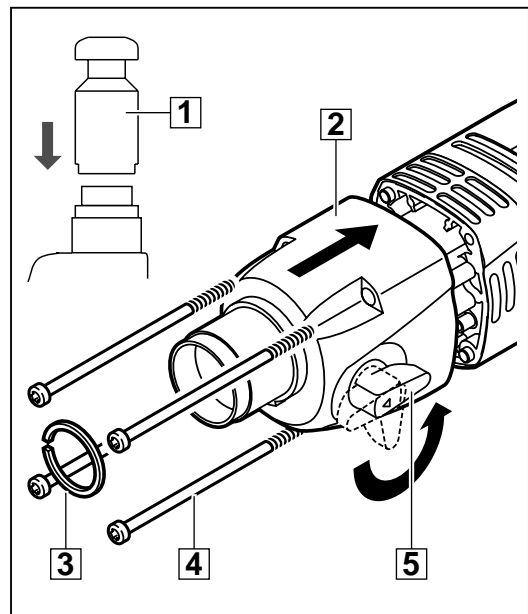

**11**

**Mounting the  
FIXTEC-  
reception**

- 1** Fit the following parts in this order:
- disk (6)
  - spring (5)
  - locking ring (4)

---

**2** Depress the locking ring (4) and insert the 6 balls (7).

---

**3** Push on the locking sleeve (2) with a jerk.

---

**4** Insert the locking ring (8).

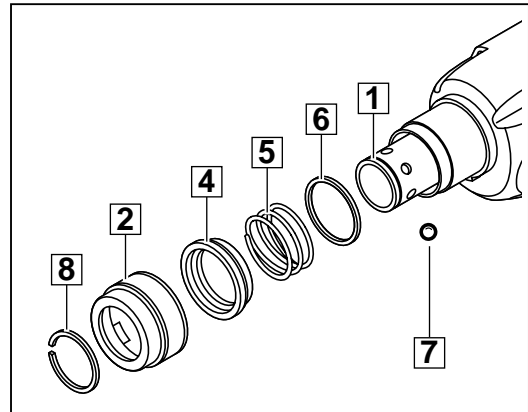
**12****Test Run**

Test run the machine and pay attention to noises.

**Electrical Test**

Perform an electrical test on the machine (see chapter Electrical and Mechanical Test Instructions).