

Important note  Due to constructional improvements several technical alterations were made at different times. As a result some parts of the dismantling and assembly instructions were changed or new paragraphs were added. Therefore it is important to pay attention to the date of manufacture of the machine which is pointed out in the instructions where necessary.

- Service Tools needed**
- Torx screwdrivers sizes 15 (4931 599 004), 20 (4931 599 005)
 - Special pliers 4931 5990 57
 - Special pliers 4931 5990 58 (resp. 4931 5990 56, 4931 5990 69)
 - Mounting device 4931 5990 39
 - Assembly service tool 4931 5990 38
 - (Dis-) Assembly tool 4931 5990 84
 - Hexagon key 4931 599 002

- Important**
- Before maintenance carry out an introduction examination with high voltage check according to VDE (see chapter Electrical and Mechanical Test Instruction).
 - Always disconnect the plug from the mains before maintenance.

Dismantling

- Dismantling the SDS-Plus-Reception**
- PHE 24 R**
PHE 26 R
- 1 Remove the rubber (1).
 - 2 Remove the spacer (2) (from date of manufacture 10/95).
 - 3 Depress the sliding sleeve (4) and lever off the seal ring (3) with a screwdriver.
 - 4 Remove the sliding sleeve (4) and the retaining ring (5).
 - 5 Depress the retaining disk (7) and press out the ball (6) with aid of a screwdriver or remove it with a magnet.
 - 6 Remove the retaining disk (7) and the spring (8).

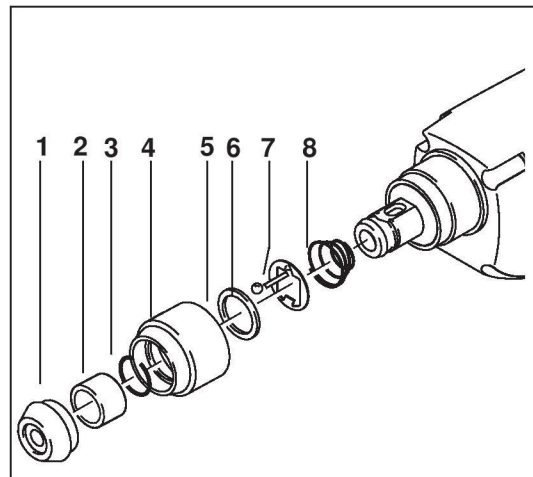

1

- Dismantling the FIXTEC-reception**
- PHE 24 RX**
PHE 30 RX 2
- 1 Removing the locking sleeve (2): Fix the locking sleeve in a pulling-off-device (3) and press an appropriate sleeve on the spindle (1).
 - 2 To remove the balls (4) (6 pieces): depress the seal ring (6) and remove the balls with aid of a magnet.
 - 3 Remove the remaining parts:
 - locking ring (6)
 - outer spring (7)
 - ejection ring (5)
 - inner spring (8)
 - washer (9)

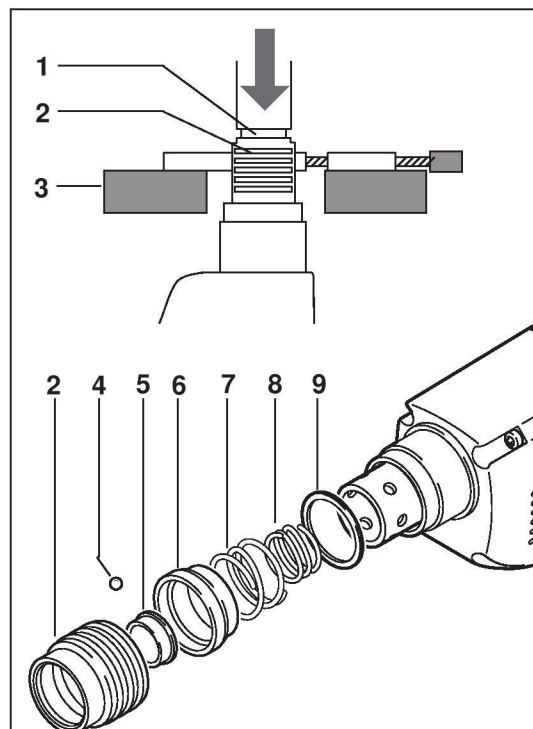

1

Removing the gear housing

- 1 Removing the gear lever (6):
Switch gear lever to „0“ and break it off with aid of pliers (the lever is being destroyed).

- 2 Only applicable for PHE 30 RX 2:
Remove the hammer switch (5) with aid of pliers (the switch is being destroyed).
☞ In case of stiffness fix the switch in a vice and bread it off by moving the machine to and fro. Remove any broken parts from the machine!

- 3 Remove the four housing screws (2).

- 4 To remove the locking ring (3) (only applicable for FIXTEC-machines): open the locking ring on the spindle with aid of special pliers (1) (4931 5990 57) and remove it together with the gear housing (4).

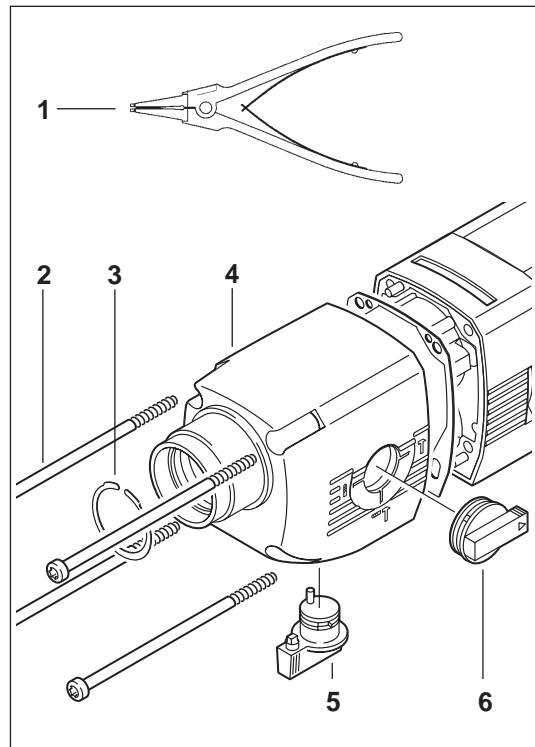

2

Removing the spindle

- 1 Remove the two screws (1).

- 2 Remove the straight pin (5).

- 3 Remove the planetary gear (6) and the ring gear (7).

- 4 Remove the complete spindle sleeve (2) from the cylinder.

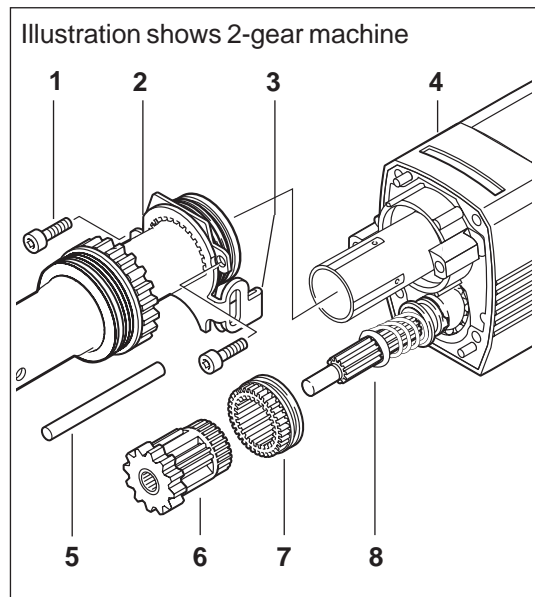

3

Removing the striker

- 1 Place the spindle vertically and briefly hit the plunger (1) with a mandril - the striker (2) comes free.

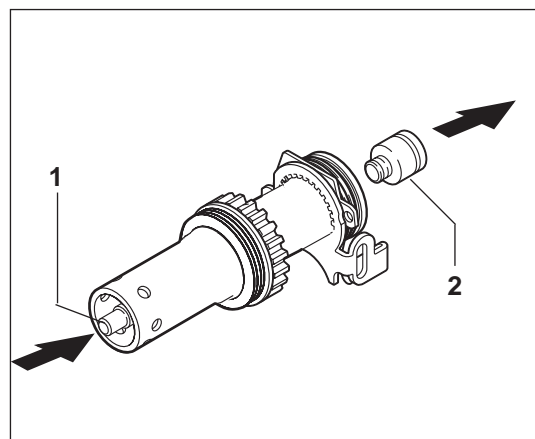

4

Dismantling the spindle (removing the inner locking ring)

- 1 Removing the rear thrust bearing (7):
Lever off the special locking ring (8) with a screwdriver and remove it (peel it off like a key ring). The thrust bearing can be removed in the following component parts:
 - washer
 - thrust bearing
 - two compensating washers
 - profile ring with damper-O-ring
- 2 Remove the retaining clip (6) and the locking slide (5).
- 3 Removing the spindle wheel (3):
Press the spindle wheel with a sleeve against the disk springs (1) – the locking ring (4) is released and can be removed with pliers. Remove the spindle wheel.
- 4 Remove the ratchet (2) and the disk springs (1).

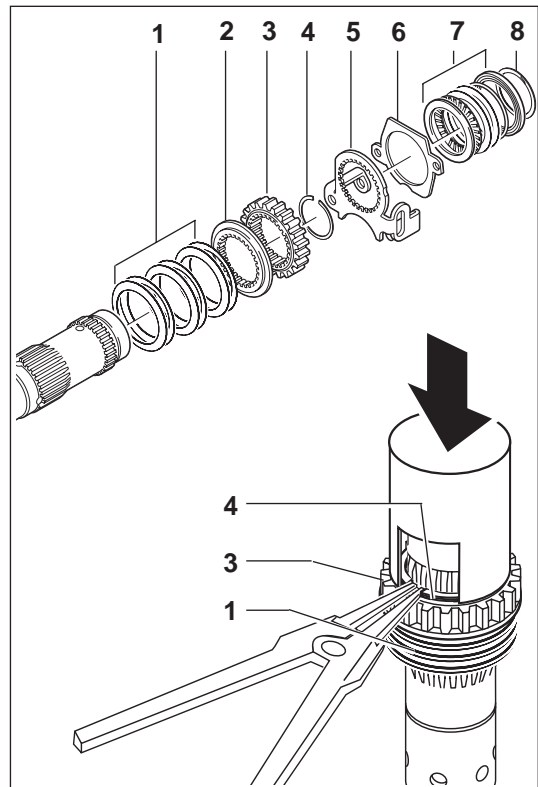

5

Dismantling the spindle (removing the inner locking ring)

- ☞ Depending on the date of manufacture of the machine there are different ways to remove the locking ring:
- Date of manufacture up to 12/95:**
Remove the locking ring (2) inside the spindle (1) with aid of special pliers (3).
- ☞ The special pliers' (3) Id-no. depend on the date of manufacturing of the tool:
- up to 05/94 = 4931 5990 58
 - from 06/94 = 4931 5990 56
 - from 08/94 = 4931 5990 56

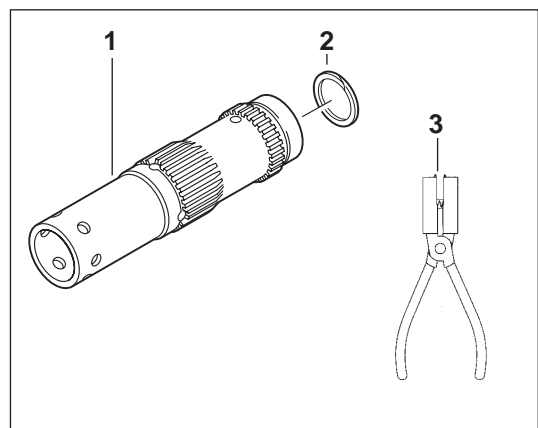

6

Date of manufacture from 09/96:

- To remove the locking ring use a special tool (1) as shown in illustration.
- 1 Turn the locking ring (2) with aid of the special tool (1) such that one end of the ring projects the service boring (3) approx. 2 mm.
 - 2 Insert a screwdriver into the service boring (3) and lift the locking ring (2) from the groove. Keep the screwdriver in place.
 - 3 Lever off the locking ring with aid of a second screwdriver inserted into the other service boring. The locking ring comes free from the inner groove of the spindle and can be removed with aid of a hook.

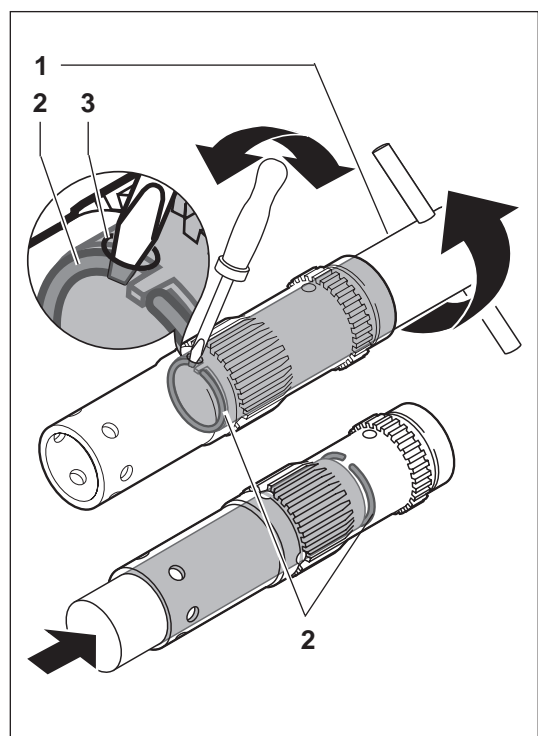

7

Dismantling the spindle (inner parts)

**PHE 24 R
PHE 26 R**

- 1 Press the following parts from the spindle:
 - washer (6)
 - pressure sleeve (5)
 - plunger (4)
 - brake disk (2) (is pressed in).
- 2 Remove the O-rings (3) and (7).

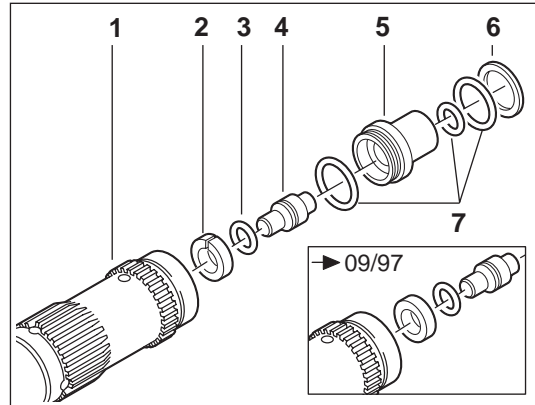

Dismantling the spindle (inner parts)

**PHE 24 RX
PHE 26 R
PHE 30 RX 2**

- 1 Press the following parts from the spindle:
 - washer (9)
 - pressure sleeve (6)
 - plunger (5)
 - brake disk (4)
 - pressure sleeve (3) (is pressed in).
- 2 Remove the O-rings (2), (7) and (8).

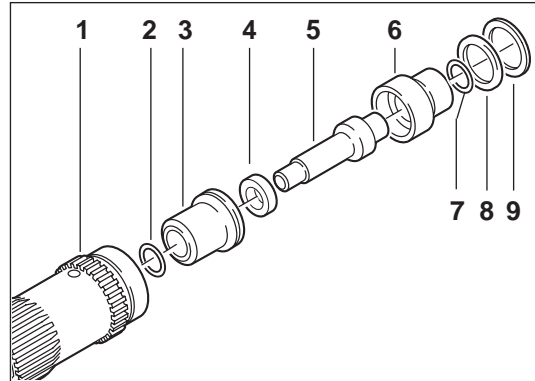

Removing the back gear shaft and the cylinder

- 1 Remove the tumble drive (4) and the cylinder (1).
- 2 Press out the bolt (2) by hand and remove the two disks (3) (older machines: guide ring (see box)).
- 3 Remove the needle bearing (5) with aid of an interior extractor. In case of older machines, remove the 13 rollers (6) from the back gear shaft.

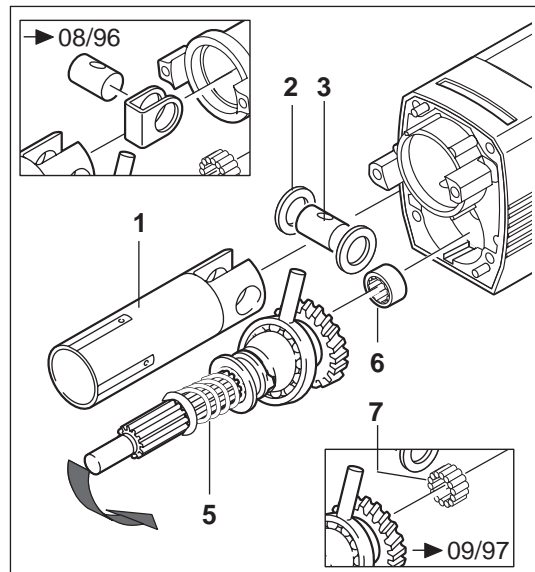

Dismantling the back gear shaft

- 1 Remove the ring (8).
- 2 Press off the back gear wheel (7).
- 3 Remove the remaining parts from the back gear shaft (1):
 - tumble drive (6)
 - washer (5)
 - coupling box (4)
 - spring (3)
 - washer (2)

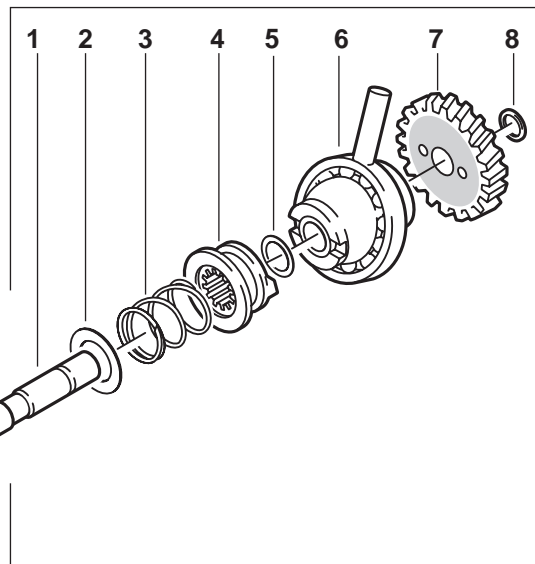

8

9

10

Dismantling the handle

- 1 Remove the service cover (6).
- 2 Remove the strain relief (5).
- 3 Loosen the cable (4).
- 4 Lever off the six handle cover (Softgrip) holders with aid of a screwdriver (see illustration) and remove the softgrip (3)
- 5 Remove the screws of the handle cover (2).
- 6 Remove the AVS-rubber (1).

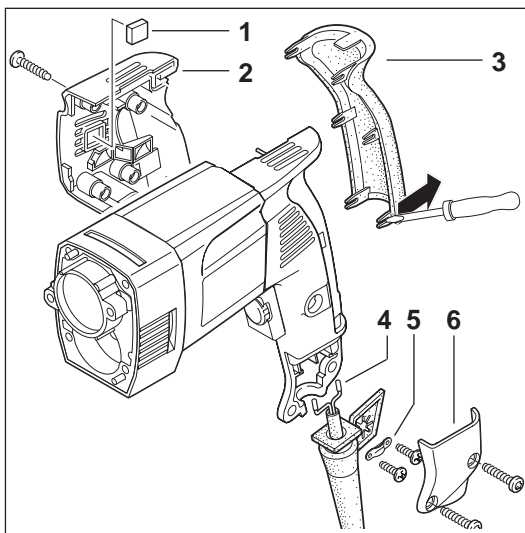

11

Dismounting the electrical parts

- 1 Unhinge the tension springs (4) and put them aside (don't take them out!) and pull out the carbon brushes (5).
- 2 Pull out the carbon brush holder (6).
- 3 Pull off the cable and remove the electrical parts.
- 4 Remove the second handle cover (1), the AVS-rubber (2), and the guide rollers (3).

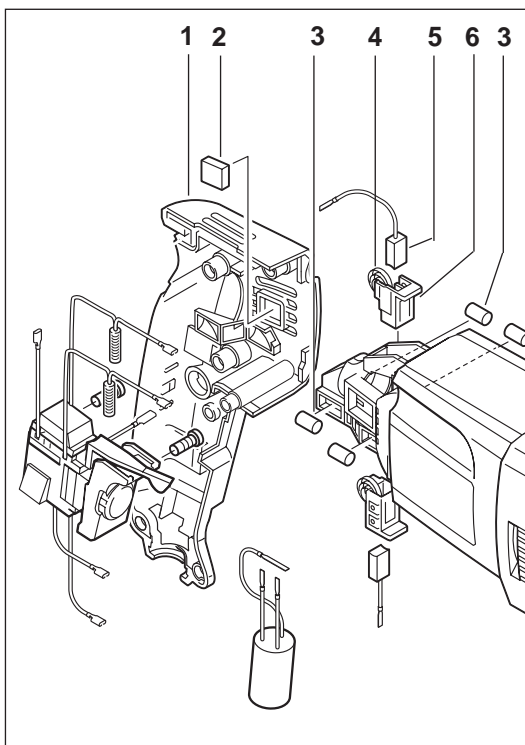

12

Removing the armature

- 1 Remove the armature (4) with the end shield (1) from the motor housing (5) (if necessary expel it by hitting it lightly with a plastic hammer).
- 2 Remove the end shield screws (2) (turn armature until reliefs in the fan (3) release the screws).
- 3 Expel the armature by hitting it lightly with a plastic hammer.

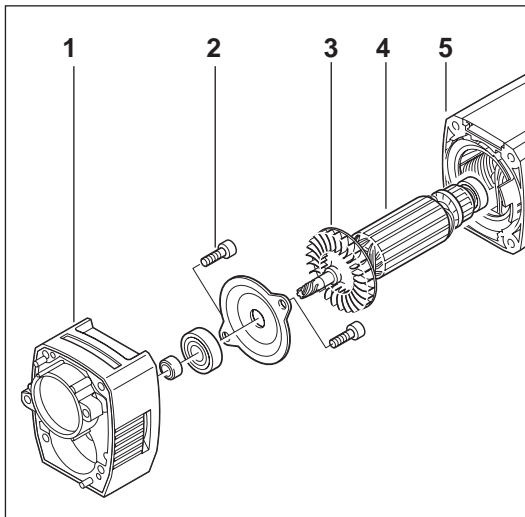

13

Removing the field

- 1 Remove the air deflector plate (1).
- 2 Lightly hit the edge of the housing with a plastic hammer and expel the field (3) from the motor housing (5).
- 3 Remove the centering ledges (2).
- 4 Remove the rubber shell (4).

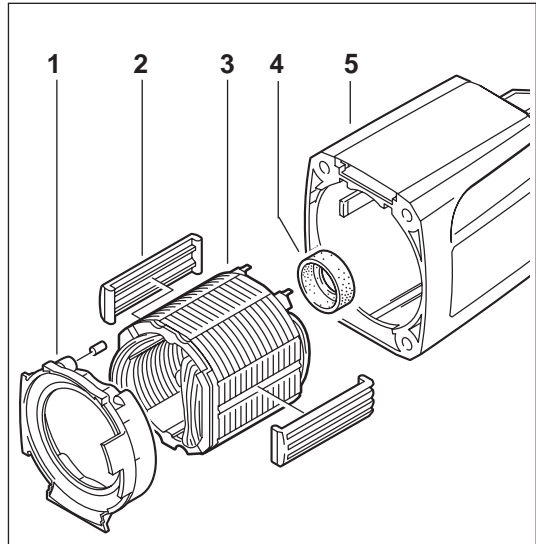

14

Maintenance

General

It is recommended to regularly submit the tool to maintenance. Maintenance is also due if the carbon brushes cut off or if the hammer mechanism fails. When carrying out maintenance all parts of the maintenance set must be exchanged. Use the appropriate maintenance set for each machine:

- PHE 24 R 4931 3431 92 (230 V)
- PHE 26 R 4931 3432 24 (230 V)
- PHE 24 RX 4931 3431 88 (230 V)
- PHE 30 RX2 4931 3432 21 (230 V)

Torque

Illustration shows 2-gear machine

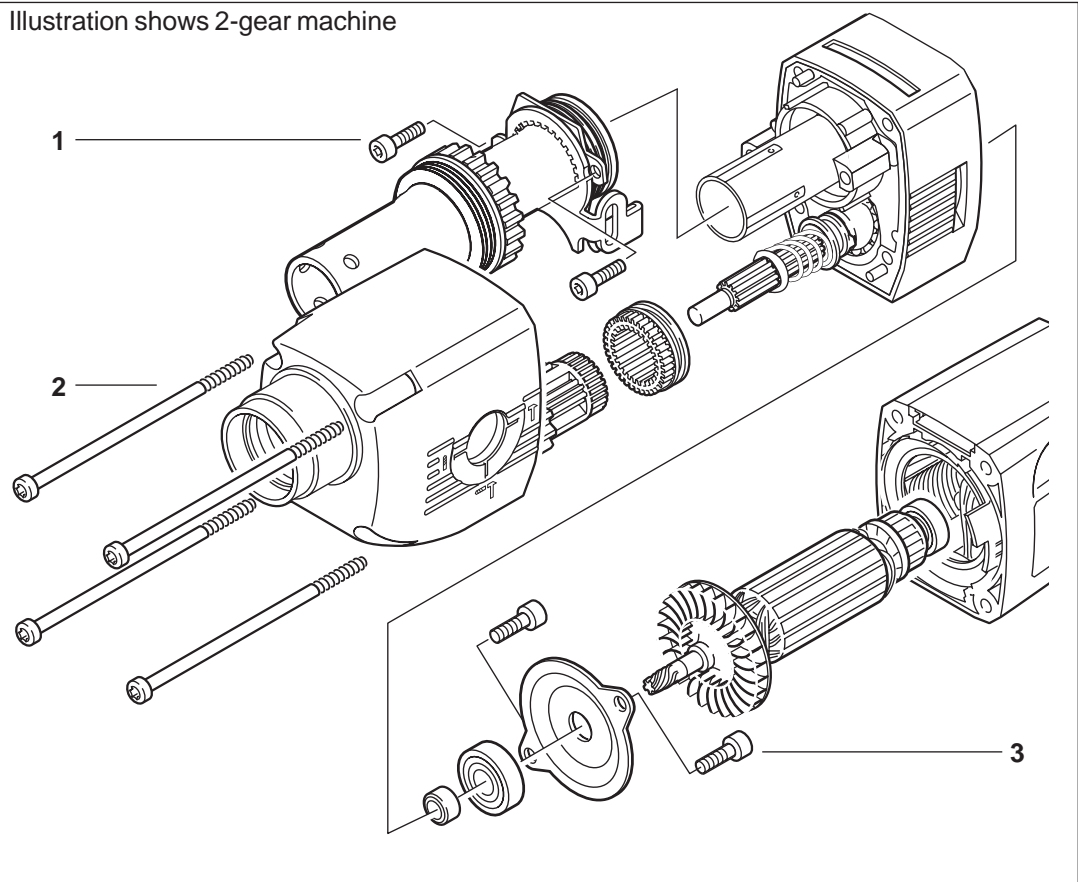

Position	Name	Torque
1	Spindle sleeve screws	6,0 Nm
2	Joining gear housing/motor housing	2,5+5 Nm
3	End shield screws	4,0 Nm

Lubrication

At each maintenance the tool must be lubricated as shown in the lubrication chart. After having dismantled the entire tool remove the used grease completely and replace it by new grease. Please pay attention to the following lubrication chart:

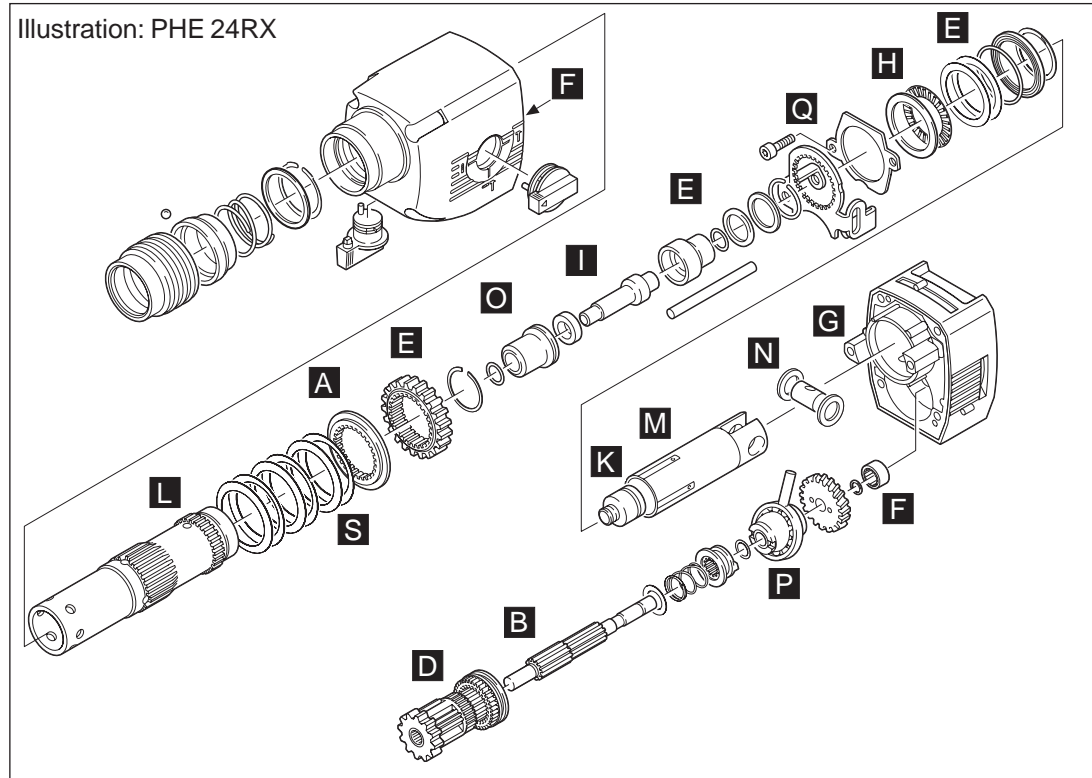

Bauteil	Bezeichnung	Fettart	Menge
A	Spindle wheel toothing	Darina	5g
B	Hollow of back gear, spindle sleeve	Darina	14g
D	Toothing of back gear	Tivela	8g
E	O-rings	Darina	1g
F	Needle bearing	Darina	je 1g
G	Porous bearing boring	Darina	1g
H	Spindle sleeve thrust bearing	Tivela	1g
I	Plunger outside	Tivela	0,5g
K	Cylinder inside	Tivela	2g
L	Spindle sleeve outside	Darina	2g
M	Cylinder outside	Darina	2g
N	Cylinder bolt	Darina	0,5g
O	Striker	Darina	0,5g
P	Tumble drive boring	Darina	0,5g
Q	Gear sleeve inside and outside	Darina	4g
S	Ratchet/spindle wheel	Darina	1g

The service set contains tubes with grease (Tivela, Darina). All items listed above must be lubricated with the stated amount of grease. With the remainder of the Darina-tube evenly lubricate the gear box and the spindle sleeve.

Cleaning

With the exception of the electrical parts all parts must be cleaned with cold cleaner. **Attention!** No cleaner must enter the encapsulated bearings. Clean the electrical parts with a dry brush.

Abrasion test

Check the dismantled parts for abrasion (visual check) and exchange if necessary.

Electrical test

Before assembly submit all relevant parts to an electrical test (see chapter Electrical and Mechanical Test Instruction).

Assembly

Note  Please additionally secure all screwed connections in metal with screw locking device.

Mounting the field

- 1 Insert the rubber shell (4).
- 2 Insert the centering ledges (2) in the field (3).
- 3 Insert the field (3) in the motor housing (5) by hitting it lightly on the rear.
- 4 Insert the air deflector plate (1).

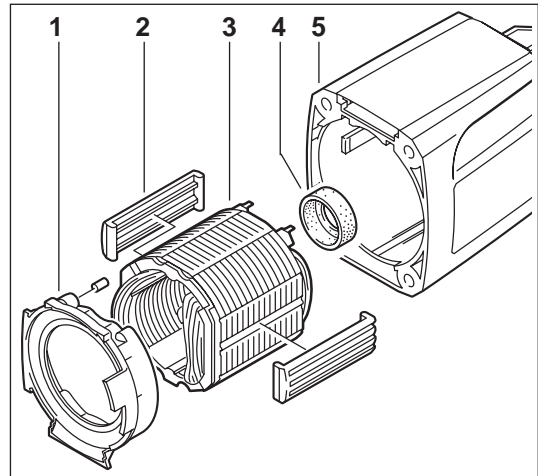

1

Mounting the armature

- 1 Insert the armature (4) in the end shield (1) by hitting the armature shaft lightly with a plastic hammer.
- 2 Turn armature until the reliefs for the end shield screws (2) are released. Fasten the armature with screws (4 Nm).
- 3 Insert the armature with end shield in the motor housing (5). Push together the end shield and the motor housing (if necessary hit it lightly with a plastic hammer).

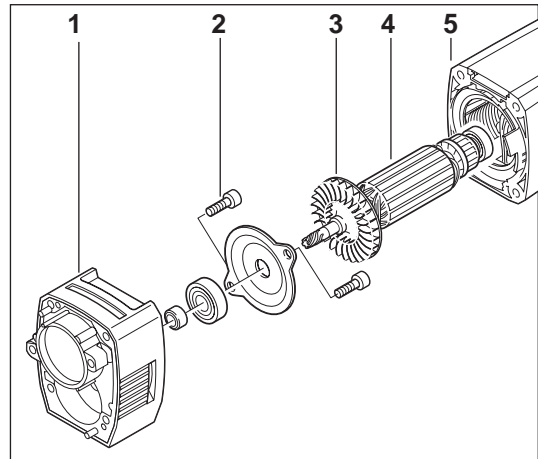

2

Assembling the electrical parts

- 1 Insert the carbon brush holders (6).
- 2 Insert the carbon brushes (5) and hang up the tension springs (4) with clasp.
- 3 Insert the AVS-rubber (2) and the guiding rollers (3).
- 4 Mount the handle cover (1) on the motor housing.
- 5 Insert the electrical parts in the handle cover and connect them according to the connection diagram.

 Make sure the cables fit properly in the housing. Cables must never be jammed when assembling.

PHE 24/26

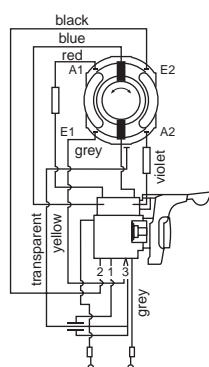

PHE 30 RX 2

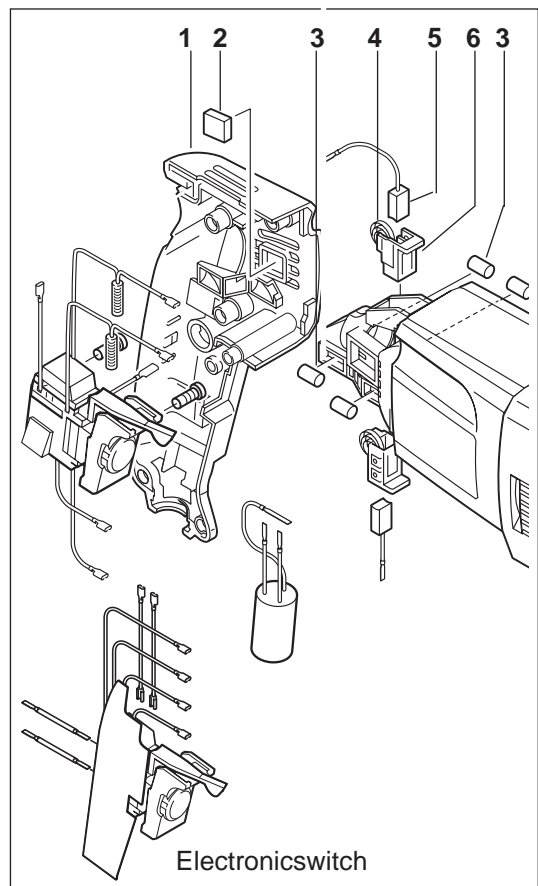
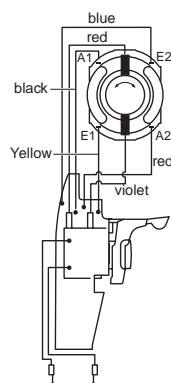

3

Assembling the handle

- 1 Insert the AVS-rubber (1).
 - 2 Fasten the handle cover (2) with screws.
 - 3 Fasten the mains cable (4).
 - 4 Fasten the strain relief (5).
 - 5 Fasten the service cover (6) with screws.
- ☞ After the high-voltage check, fit the Softgrips (3).

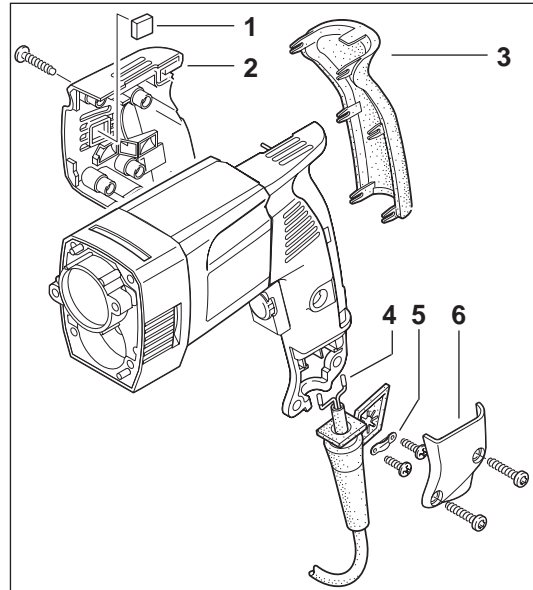

4

Assembling the back gear shaft

- 1 Push the following parts onto the back gear shaft (3) in this order:
 - washer (4)
 - spring (5)
 - coupling box (6)
 - washer (7)
 - tumble drive (2)
- 2 Press on the gear wheel (1) with a distance of 0.05 mm to the tumble drive (2) (illustration A). The smooth surface must face the tumble drive (2).
- 3 Insert the locking ring (8).

Illustration A

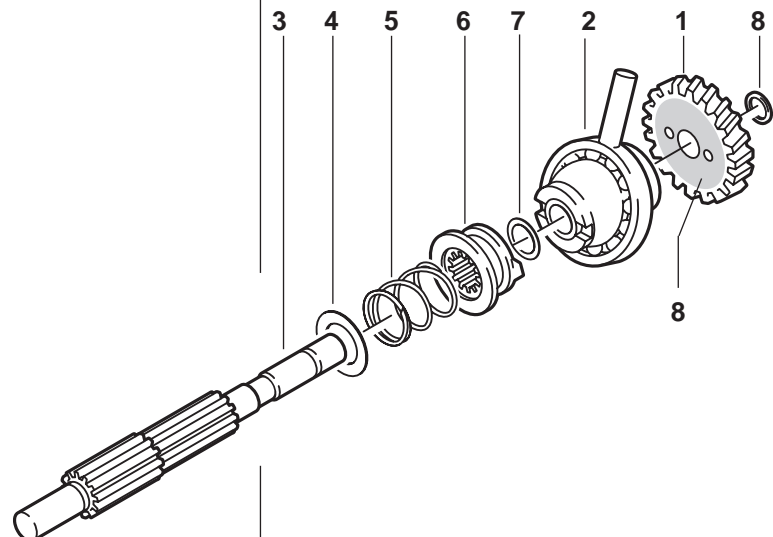
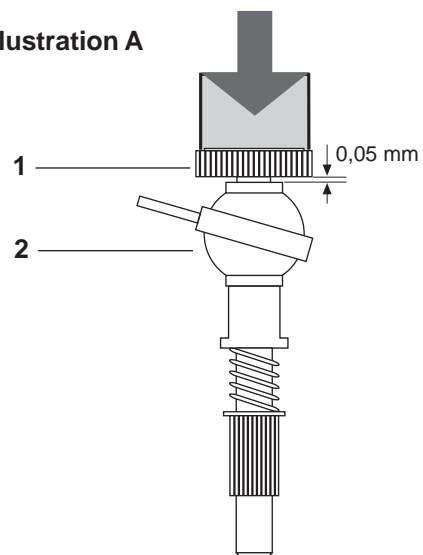

5

Mounting the back gear shaft and the cylinder

- 1 Insert the guide ring (4) and the bolt (3) into the cylinder (2).
- 2 Insert the rolls (6) into the back gear shaft one after the other and fix it with grease.
 ☞ Mount the rolls (6) completely with the cage (from date of manufacture 06/96).
- 3 The back gear (7) can only be inserted as follows:
 - Put together the cylinder and the back gear for adjustment before mounting them.
 - Turn the tumble drive to the lowest position and leave it there
 - insert the cylinder into the end shield
 - Insert the tumble drive into the mounted cylinder.
- 4 Grease the striker (1) and insert it into the cylinder.

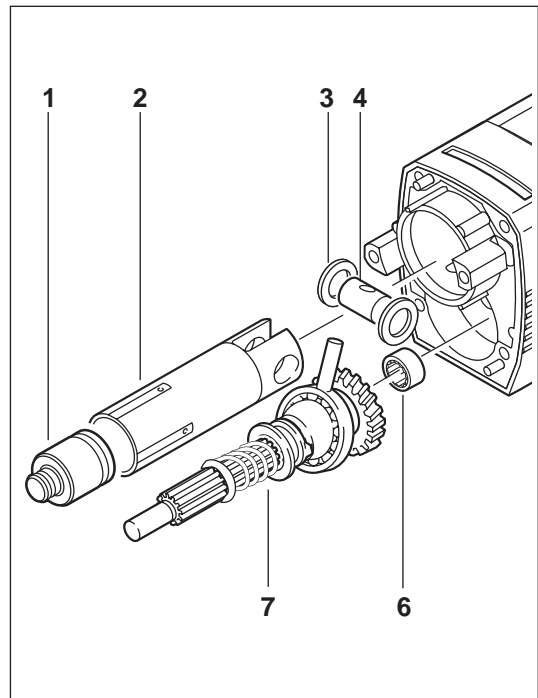

6

Assembling the spindle (mounting the inner parts)

PHE 24 R
PHE 26 R

☞ From date of manufacture 01/96 the spindle is provided with service borings for easy removing of the locking ring (7). Older spindles must be exchanged for new ones.

- 1 Push the O-rings (8) onto resp. into the pressure sleeve (5).
- 2 Fit the brake disk (2), the O-ring (3), and the pressure sleeve (5) to the plunger (4) and insert them into the spindle (1).
- 3 Insert the washer (6) into the spindle until on top of the O-ring.
- 4 Press the locking ring (7) with a used cylinder into the spindle until the locking ring engages. Visual check!

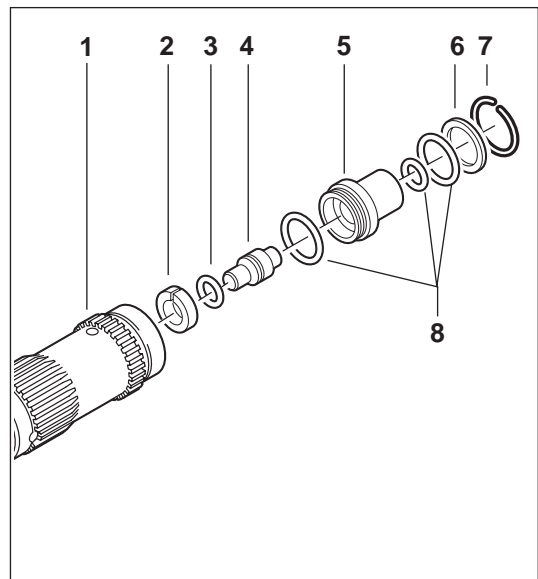

Assembling the spindle (mounting the inner parts)

PHE 24 RX
PHE 30 RX 2

- 1 Insert the O-rings (2) and (7) into the pressure sleeves (3) and (6). Fit the ring (8) to the pressure sleeve (6).
- 2 Press the pressure sleeve (3) into the spindle (1).
- 3 Push the brake ring (4) and the pressure sleeve (6) over the plunger and insert them into the spindle (1).
- 4 Insert the washer (9) into the spindle until on top of the O-ring (8).
- 5 Press the locking ring (10) with a used cylinder into the spindle until the locking ring engages. Sight control through the service

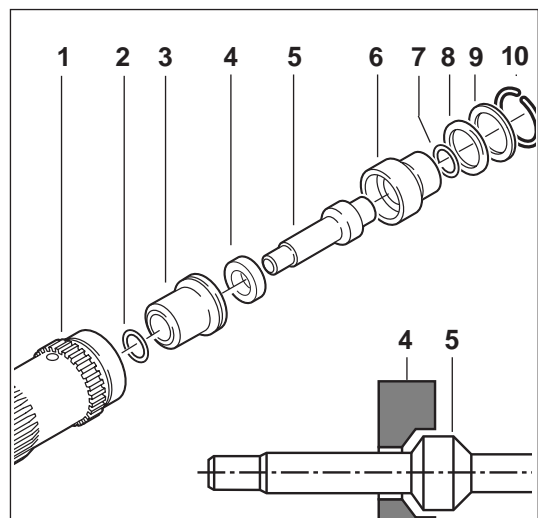

7

Assembling the spindle (mounting the outer parts)

- 1 Mount the disk springs (1) with the bulgings head-on (see illustration)
- 2 Mount the clutch (the ratchet (2) with indentations against the tooting of the spindle wheel (3)).
- 3 Fit the locking ring (4) and press it on against the pressure of the disk springs.
- 4 Mount the locking slide (5) and the retaining clip (6).
- 5 Mounting the rear thrust bearing (7):
- profile ring with damper-O-ring
- two compensating washers
- thrust bearing
- washer
- 6 Secure the rear thrust bearing (7) with the special locking ring (8).

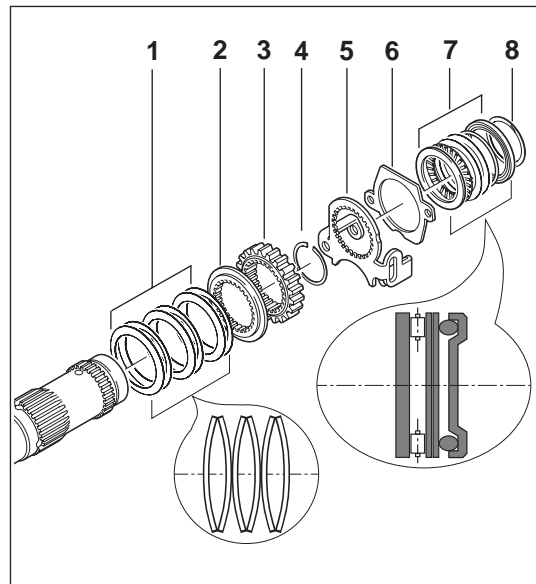

8

Mounting the spindle

- 1 Fit the spindle (2) to the end shield (4) and fasten it with two screws (1) (6 Nm).
- 2 Push the ring gear (7) over the back gear shaft (8) and let it engage in the locking slide (3).
- 3 Push the planetary gear (6) onto the back gear shaft and fit them into the ring gear (7).
- 4 Push the straight pin (5) through the locking slide (3) and insert it into the end shield (4).

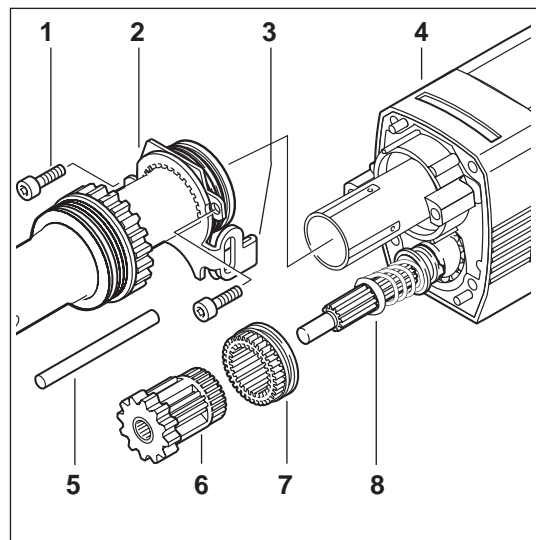

9

Mounting the gear housing

- 1 Insert the sleeve (1) (service tool No. 4931 5990 38) into the gear housing (2) (the sleeve protects the rotary shaft seal in the gear housing from damage during assembly).
- 2 Fit the gasket (3) to the end shield (4).
- 3 Fasten the gear housing (2) to the end shield (4) and fix it with screws (2,5+5 Nm).
- 4 Fit the gear lever (5) (mount it in the "hammer" position, the pin must grasp the elongated hole of the locking slide).
- 5 Only applicable for PHE 30 RX 2: Press on the hammer switch (7) (mount in in the „hammer“-position).

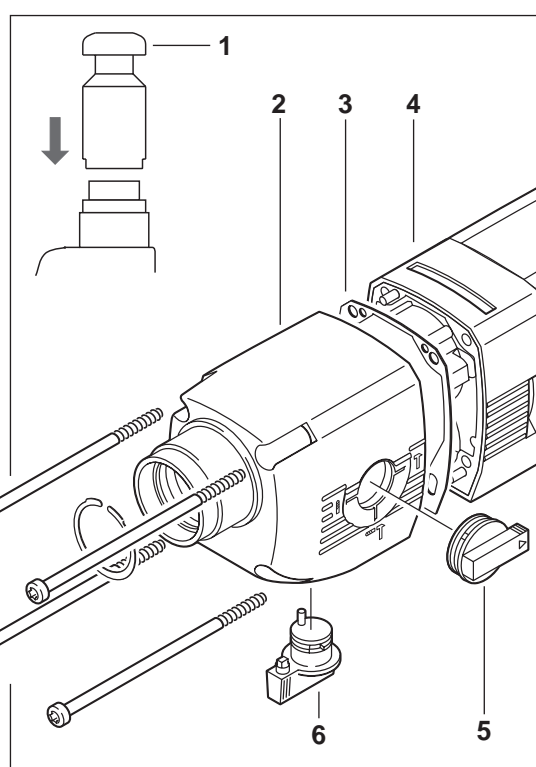

10

**Mounting the
SDS-plus
Reception**

**PHE 24 R
PHE 26 R**

- 1 Insert the spring (8) and the retaining disk (7).
- 2 Depress the retaining disk (7) and insert the ball (6).
- 3 Fit the retaining ring (5) and the sliding sleeve (4).
- 4 Depress the sliding sleeve and insert the seal ring (3) into the pass.
- 5 Fit the spacer (2).
- 6 Push down the sliding sleeve and fit the rubber (1).

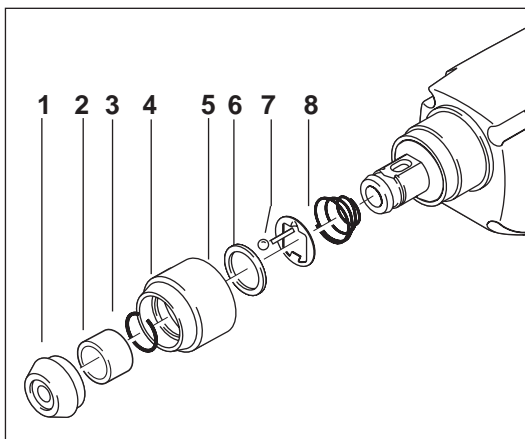

11

**Mounting the
FIXTEC-reception**

**PHE 24 RX
PHE 30 RX 2**

- 1 Press in the seal ring (2) with aid of a sleeve (1) (service tool No. 4931 5990 38) until it engages.
- 2 Fit the following parts in this order:
 - washer (9)
 - inner spring (8)
 - outer spring (7)
 - locking ring (6)
- 3 Depress the locking ring (6) and insert the balls (4).
- 4 Insert the ejector ring (5).
- 5 Depress the locking ring (6) (take care that the balls cannot fall out) and press in the ejector ring (5) with a used SDS-plus adapter.
- 6 Press a locking ring into the spindle in order to secure the ejector when mounting the locking sleeve (3).
- 7 Fix the locking sleeve (3).
- 8 Remove the locking ring fitted to secure the ejector.

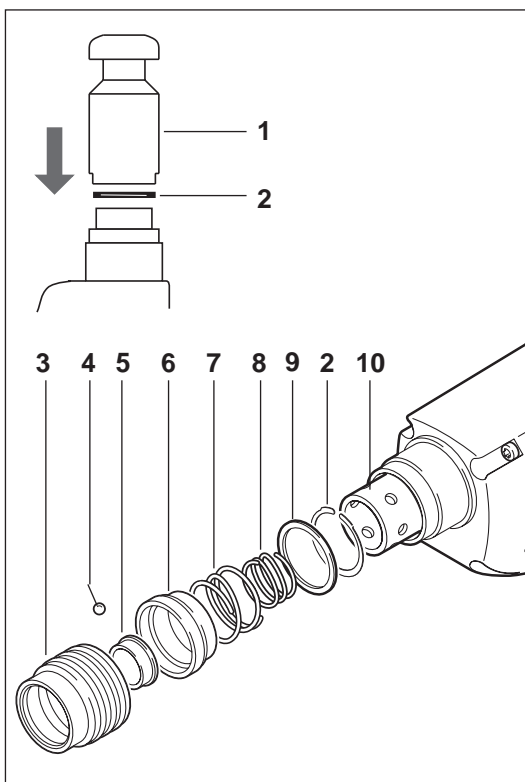

12

**Test run and
electrical
examination**

Carry out a test run and check for strange noises.
Carry out an electrical examination. (See chapter Electrical and Mechanical Test Instruction).