

Опубликовано на сайте [www.rem-5.ru](http://www.rem-5.ru)

**Special Tools  
Require**

- Torx screwdriver TX 1 4931 599 004
- Torx screwdriver TX 20 4931 599 005
- Torx screwdriverbit TX 30 4932 319 998
- Permanent-magnet holder 4932 315 508
- Forcing disks 4931 599 021
- (Dis-)Assembly tool 4931 599 011

**Important!**

- Before beginning the maintenance work, perform an initial check with a high voltage test according to VDE (see chapter Electrical and Mechanical Test Instructions).
- Before all repair work, pull the power plug from the socket!

**Disassembly**

**Detaching the  
holding grip**

- 1 Remove the depth gauge (2) with the holding device (3) from the tool.
- 2 Remove the holding device (3) from the depth gauge (2).
- 3 Remove the holding grip (1).
- 4 Remove the locking ring (9) with aid of special pliers and remove the O-ring (8).
- 5 Remove the plastic holder (7) from the tool.
- 6 Remove the pin (4) and the nut (6) from the clamping plate (5).
- 7 Slightly bend up the clamping plate (5) and push it off.

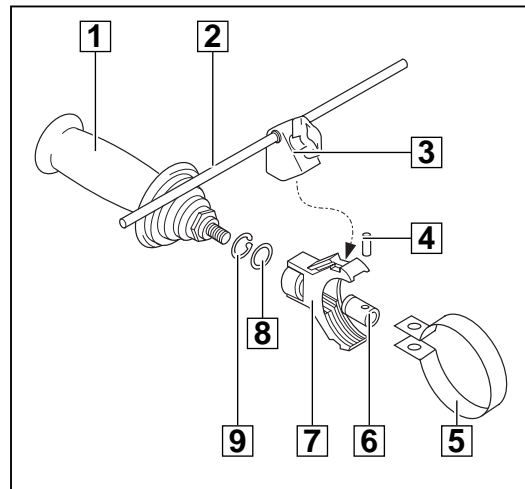

1

**Detaching the  
switch knob**

- 1 Remove the four screws (6).
- 2 Carefully lever off the gear box insulation (3) at the edge using a screwdriver.
- 3 Remove the O-ring (5) from the gear box insulation (3). Remove the locking ring (4) with aid of special pliers.
- 4 Lever off the switch knob (9) from the outside and remove it together with the pressure spring (1) as well as the ball (2).
- 5 Remove the shift pin (7) and the torsion spring (8) from the gear box insulation (3).

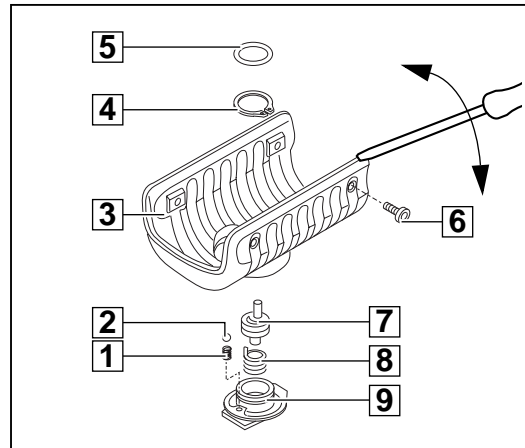

2

**Removing the armature**

- 1 Loosen the four screws (B) and remove the motor housing cap (A).
- 2 Remove the respective brush springs (2) from the carbon brushes (D) and place them on the upper edge of the brush holder (E).
- 3 Pull the cable lugs (1) and (C) from the carbon brushes (D) and pull out the carbon brushes.
- 4 Slightly lift the brush holder (E), unlatch them (see arrow) and take them out.
- 5 Remove the armature (6) completely with the fan (7) from the motor housing (3) by turning it. If necessary, use a plastic hammer for support.
- 6 Remove the bearing bush (9) from the ball bearing (8).
- 7 Press the ball bearing (8) as well as the ball bearing (4) from the armature with aid of the forcing disks (service tool).
- 8 If necessary, press the fan (7) from the armature (6).
- 9 Remove the plug (5) from the armature (6).

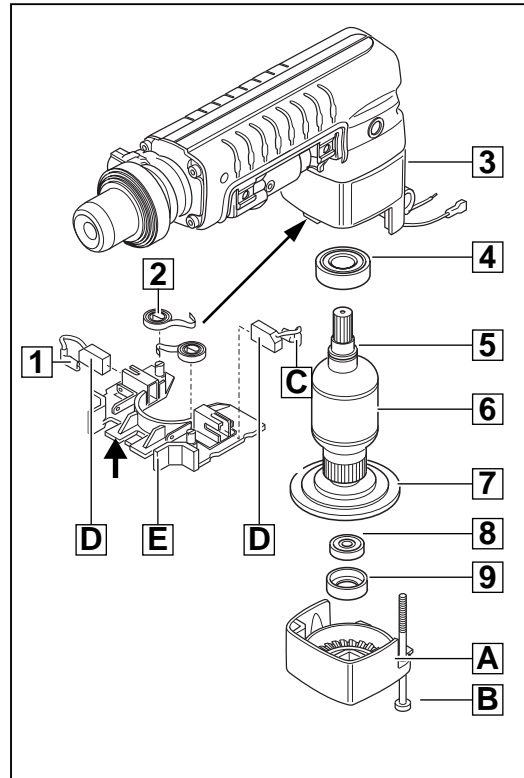

3

**Removing the electric components**

- 1 Remove the handle screw (B) steadying the knurled nut (5) at the same time. Remove the knurled nut (5).
- 2 Loosen the screw (2).
- 3 Loosen the screw (9) and lever off the soft grip (8).
- 4 Remove the handle shell (6) with the holding-down device (3).
- 5 Loosen the cable clamp (7) and lay bare the connection cable (E) with the protection cover (D). Pull off the switch connection wires (a) - (f).
- 6 Remove the switch (C) with handle shell (6).
- 7 Remove the sleeves (4) and the handle shell (A).

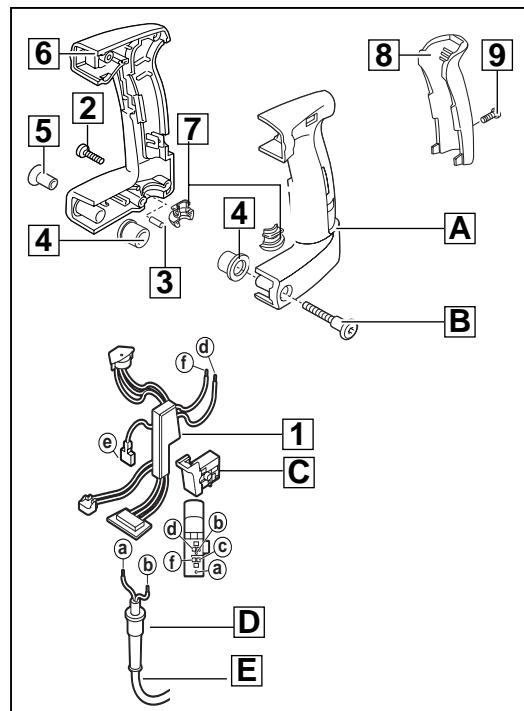

4

**Detaching the field**

- 1 Remove the motor housing (1) with the field (2) from the crankcase.
- 2 Loosen the two screws (3) and remove the field (2) from the motor housing. If necessary, use a plastic hammer for support.

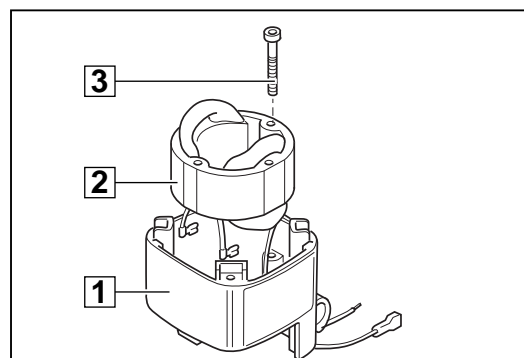

5

**Detaching the damping element**

- 1** Loosen the two screws (4) and remove the gear box insulation (2) and (3).
  - 2** Undo both screws (5) of the handgrip holder (7) and remove them together with the discs (6).
  - 3** Remove the handgrip holder (7) and the damping element (8).
-  Attention: Do not dismantle the damping element (8)!
- 4** Remove the rubber collar (1).

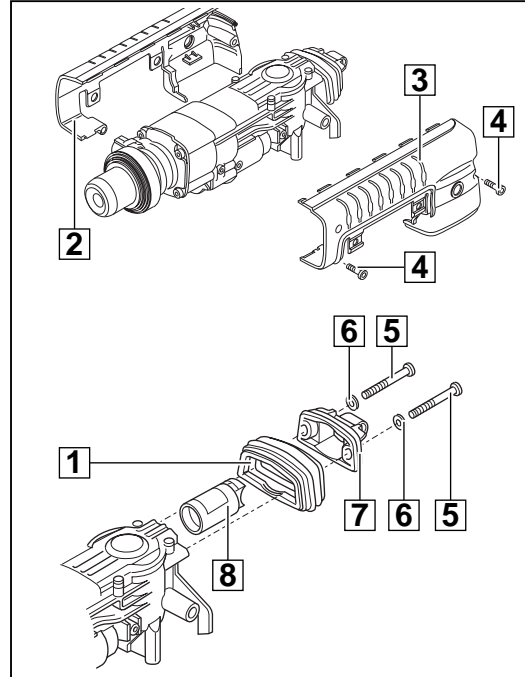

**6**

**Removing the crankcase top cover**

- 1** Lever off the cap (5).
- 2** Remove the four screws (6).
- 3** Loosen the screw (4) steadying the crank gear from below with aid of a screwdriver (see arrow).
- 4** Remove the crankcase top cover (3) and the gasket (7).
- 5** Remove the locking ring (2) with aid of special pliers and push out the ball bearing (1).

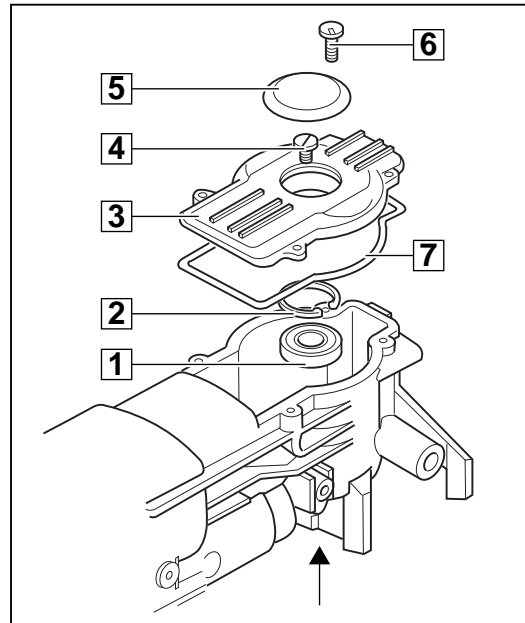

**7**

**Detaching the bearing end plate**

- 1 Lever off the cap (3) with aid of a screw-driver.
- 2 Remove the distance sleeve (4) and the sleeve (5) from the machine.
- 3 Remove the four screws (F). The screws are very tight, since they were secured with locking agent.
- 4 Remove the flange (E).
- 5 Remove the distance sleeve (6) and the sleeve (7).
- 6  Remove both locking levers (C) by depressing the retaining plate (D) against resilience. Remove the retaining plate (D).
- 7 Remove the pressure spring (B).
- 8 Remove the bearing end plate (1) completely with the spindle sleeve from the crankcase (8).
- 9 Remove the gasket (2).
- 10 Remove the backing flange (A) and the felt washer (9).

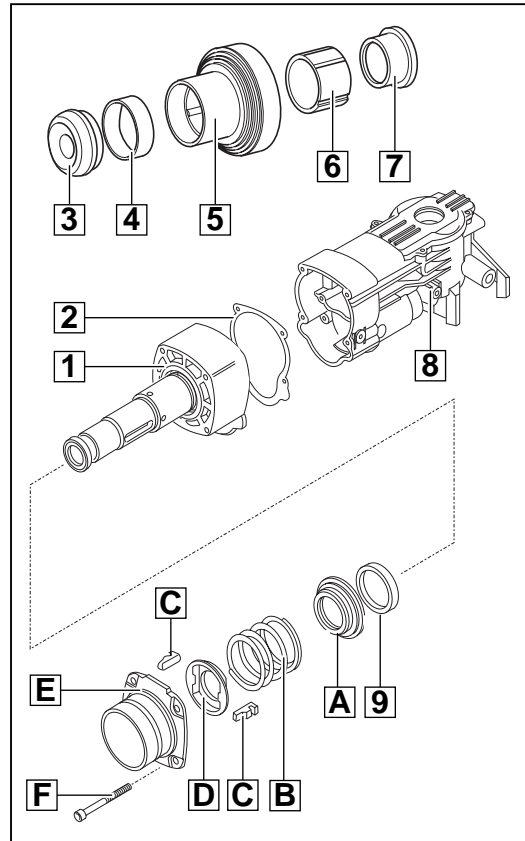

8

**Dismantling the spindle**

- 1 Press the spindle sleeve (7) with the spindle gear (G) from the bearing end plate (A).
- 2 Lever off the seal ring (8).
- 3 Remove the locking ring (9) with aid of special pliers.
- 4 Remove the needle bearing (B), the disks (C and E), the cup springs (D) as well as the needle bearing (F) from the bearing end plate (A).
- 5 Remove the four pins (H) with aid of a magnet.
- 6 Remove the spindle sleeve (7) with the O-ring (6) from the spindle gear (G).
- 7 Remove the O-ring (N), the snap die (M), the disk (L), the O-ring (K) and the disk (J) from the spindle gear (G).
- 8 Loosen two screws (1) and remove the cylinder (4) with the percussion body (2) as well as the seal ring and the O-ring (3) from the crankcase (5).

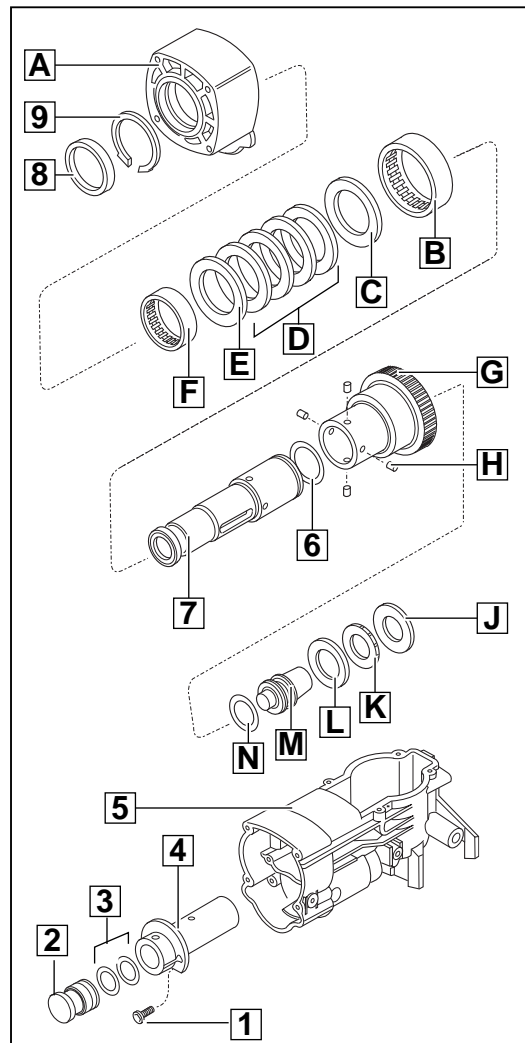

9

**Dismantling the reduction gear**

- 1 Loosen two screws (H).
- 2 Remove the bearing (G) and the reduction gear shaft assembly (E).  
 ⚠ If necessary, expel the reduction gear shaft assembly (E) with aid of a plastic hammer.
- 3 Depress the bevel gear (4) with aid of the (dis-) assembly tool (service tool). Keep it depressed and remove the locking ring (5) with aid of special pliers.
- 4 Remove the bevel gear (4), the ball bearings (3 and F), the needle bearings (7 and 2), the coupling (1), the backing flange (8), the pressure spring (9), the coupling sleeve (A), the coupling (B), the balls (C), the indexing sleeve (D) from the reduction gear shaft (E).

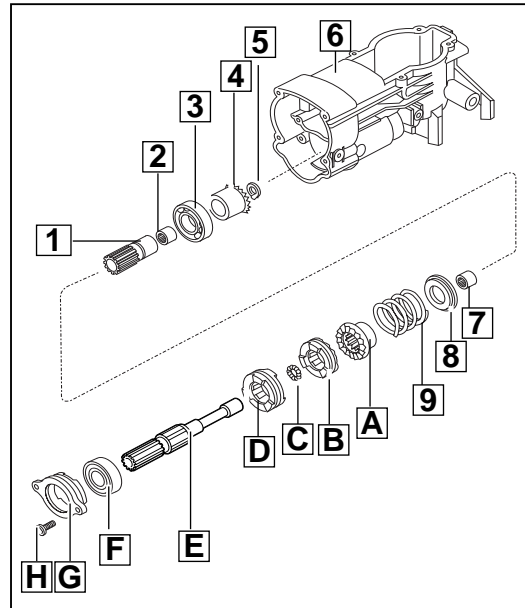

10

**Dismantling the crank assembly**

- 1 Turn the crank gear (3) until the piston (5) is located in the back dead centre.
- 2 Slightly lift the connecting rod (7).
- 3 Turn the crank gear (3) until it can be removed from the crankcase (1). Remove it together with the connecting rod (7), completely with piston (5) and O-ring (4).  
 ⚠ Do not apply any force! Do not jam the piston (5) and the connecting rod.
- 4 Pull out the needle bearing (2) with an interior extractor (9) in direction of arrow (see illustration below).
- 5 Press the pin (6) from the piston (5) and remove the piston (5).
- 6 Push the needle bearing (8) from the connecting rod (7).

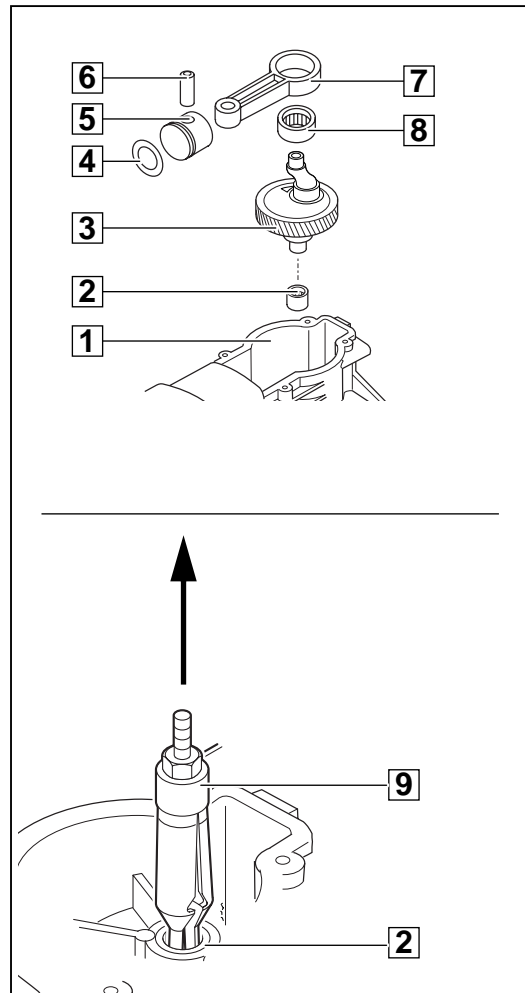

11

## Maintenance

<b>General</b>	It is recommended that maintenance be performed on the machine at regular intervals or when the carbon brushes switch off at the latest.
<b>Cleaning</b>	Clean all parts – with the exception of the electrical parts – with cold cleaning agent. Caution! No cleaning agent should penetrate into the bearing. Clean the electrical parts with a dry brush.
<b>Check for wear</b>	Check the disassembled parts for wear (visual inspection) and replace worn parts.
<b>Electrical tests</b>	Before reassembling, perform an electrical test on all relevant parts (see chapter Electrical and Mechanical Test Instructions).
<b>Lubrication</b>	Each time maintenance is performed, the machine is to be lubricated as stated in the lubrication plan. After the machine is fully disassembled, completely remove the old grease and replace with new grease. The grease must be applied to the machine as indicated in the lubrication plan.

### Legend

Distribute the grease type N (125 g) from the maintenance set as follows:

- A** Thinly daub
- B** Generously cover
- C** Fill with 43 g grease
- D** Fill with 28 g grease

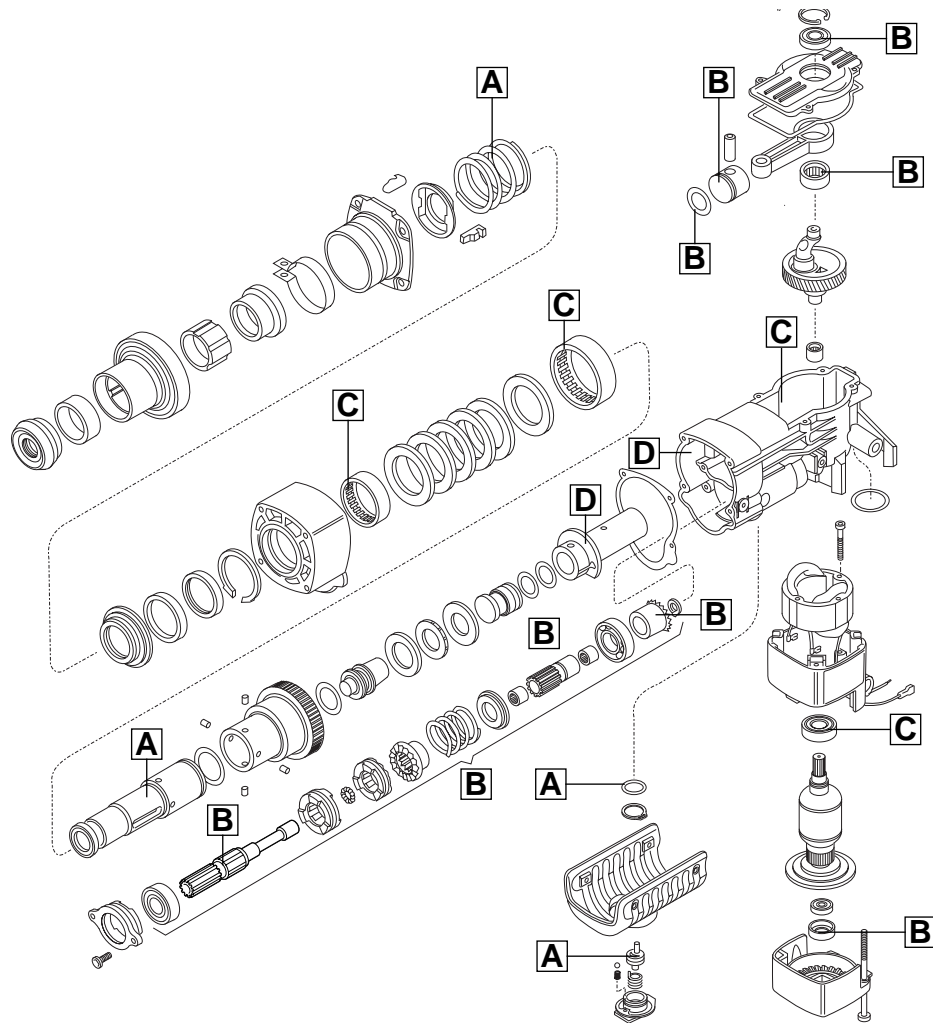

<b>Torques</b>	Screws in plastic	1.8 Nm
	Screws in metal	4.0 Nm
	Gear box screws	15.0 Nm

■ Use locking agent for all metal housing screws!



## Assembly

### Assembling the crank assembly

- 1 Mount the needle bearing (8) in the connecting rod (7).
- 2 Push the piston (5) over the connecting rod (7) and mount the pin (6).
- 3 Press the needle bearing (2) into the crank gear.
- 4 Insert the crank gear (3), the connecting rod (7), the piston (5) and the O-ring (4) into the crankcase (1). Mind the right position!  
Turn the crank gear (3) until the piston (5) is located in the back dead centre.

 Do not apply any force! Do not jam the piston (5) and the connecting rod.

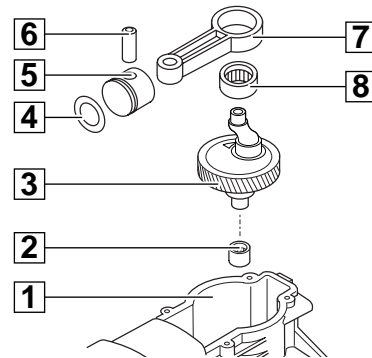

1

### Assembling the reduction gear

- 1 Push the bevel gear (4), the ball bearings (3 and F), the needle bearings (7 and 2), the coupling (1), the backing flange (8), the pressure spring (9), the coupling sleeve (A), the coupling (B), the balls (C), the indexing sleeve (D) over the reduction gear shaft (E) as shown in illustration.

 Fix the single balls (C) with grease.

- 2 Depress the bevel gear (4) with aid of the assembly tool (service tool). Keep it depressed and mount the locking ring (5) with aid of special pliers.
- 3 Mount the bearing (G) on the reduction gear.
- 4 Insert the reduction gear completely into the crankcase and fasten it with the two secured screws (H) (4 Nm).

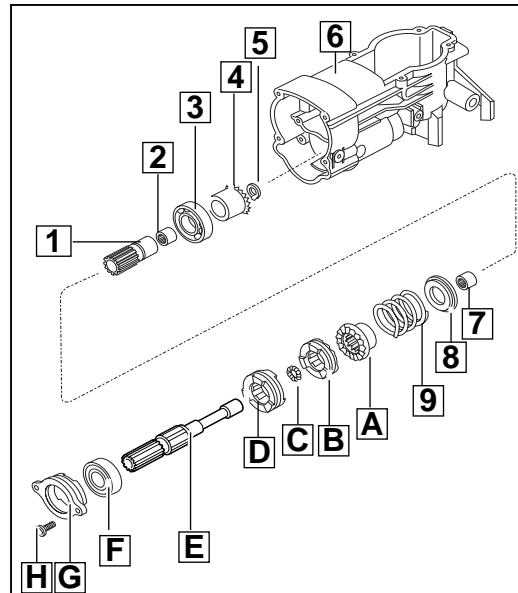

2



**Assembling the spindle**

- 1 Lightly grease the inner wall of the cylinder (4) and push it over the piston (O) (the piston is illustrated on page 7, pos.5, ill. 1).
- 2 Insert the cylinder (4) with the percussion body (2), as well as the seal ring and the O-ring (3) into the crankcase (5) and fasten them with the four secured screws (1).
- 3 Insert the O-ring (N), the snap die (M), the disk (L), the O-ring (K) and the disk (J) into the spindle gear (G). Fit the disk (L) with the phase facing the snap die. Mind the right position!
- 4 Push the spindle sleeve (7) with the O-ring (6) over the spindle gear (G).
- 5 Lock the spindle gear with the four pins (H) using a magnet for support.
- 6 Mount the needle bearing (B), the disks (C and E), the cup springs (D) as well as the needle bearing (F) in the bearing end plate (A).
- 7 Mount the locking ring (9) with aid of special pliers.
- 8 Insert the seal ring (8) into the bearing end plate (A).
- 9 Push the spindle sleeve (7) with the spindle gear (G) into the bearing end plate (A).

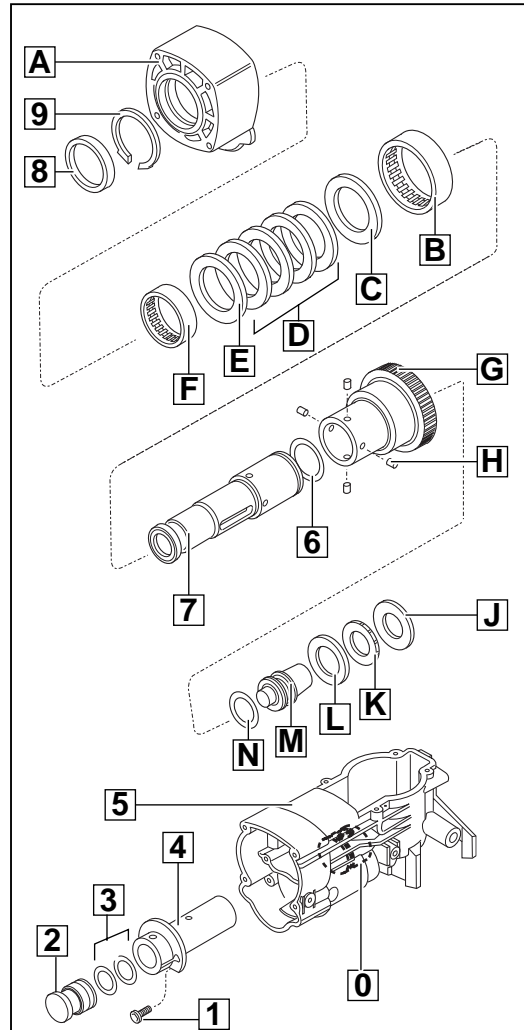

3

**Mounting the bearing end plate**

- 1 Push the backing flange (A) and the felt washer (9) over the spindle sleeve.
- 2 Fit the gasket (2) and the bearing end plate (1) completely with the spindle sleeve to the crankcase (8).
- 3 Push the pressure spring (B) and the retaining plate (D) over the spindle sleeve and depress them.
- 4
  -  Press in both locking levers (C) from the side against resilience.
- 5 Push the distance sleeve (6) and the sleeve (7) over the spindle sleeve.
- 6 Push the flange (E) over the spindle sleeve (7) and fasten it tightly with the four secured screws (F) (15 Nm).
- 7 Push over the distance sleeve (4) and the sleeve (5).
- 8 Mount the cap (3).

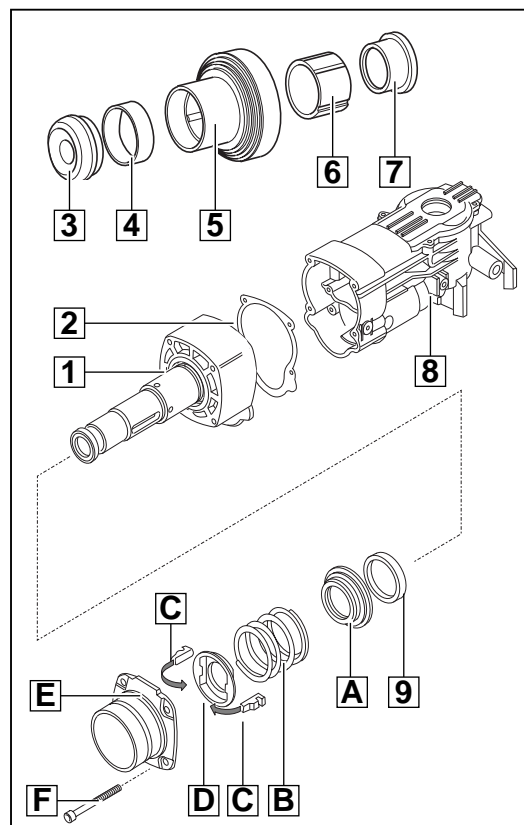

4

**Mounting the crankcase top cover**

- 1 Press the ball bearing (1) onto the crank gear.
- 2 Mount the locking ring (2) with aid of special pliers.
- 3 Fit the crankcase top cover (3) and the gasket (7) to the crankcase.
- 4 Fasten the screw (4) from below with aid of a screwdriver by steadying the crank gear (see arrow).
- 5 Fasten the crankcase top cover (3) with the four screws (6).
- 6 Fit the cap (5) to the crankcase top cover (3).

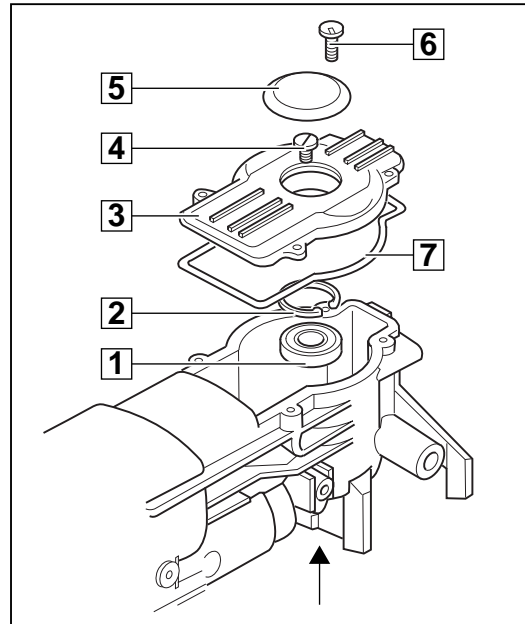

5

**Mounting the damping element**

- 1 Insert the rubber collar (1) into the crankcase.
  - 2 Insert the handgrip holder (5) and the damping element (6) into the crankcase.
  - 3 Fit the gear box insulations (2) and (3) to the machine and fasten them with the two screws (4).
- ☞ Insert the gear box insulations (2) and (3) at an angle such that the toothings will interlock properly.

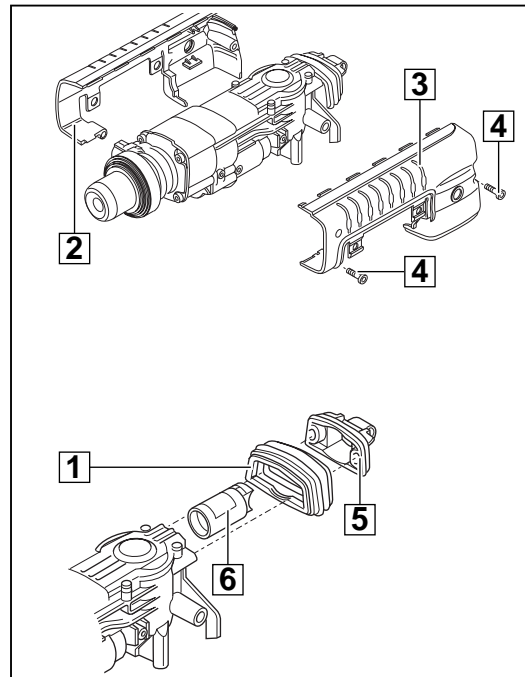

6

**Mounting the field**

- 1 Insert the field (2) into the motor housing. Mind the right position!
- 2 Fasten the field (2) with the two screws (3).
- 3 Fit the motor housing (1) with the field (2) to the crankcase.

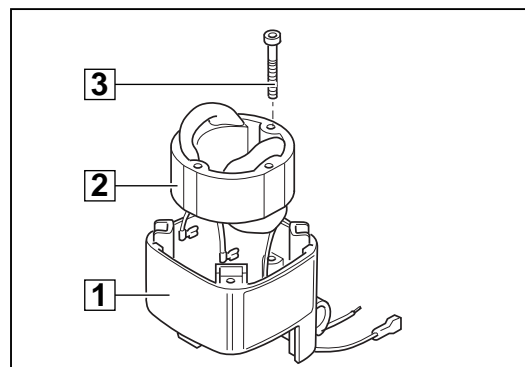

7

**Mounting the electric components**

- 1** Insert a sleeve (4) into the handle shell (A) and fit the handle shell to the motor housing.
- 2** Mount the second sleeve (4) , the electronic element (1), and the switch board (C) in the handle (6).
- 3** Wire the switch connections. **See illustration on the right and the circuit diagram below.**
- 4** Lay the connection cable (E) with the protection cover (F) in the handle shell (6) and connect it with the switch (C).
- 5** Put the handle (6) with the holding down device (3) on the other half of the handle (A).
- 6** Fit the soft grip (8) and fix it with the screw (9).
- 7** Insert the knurled nut (5) into the handle shell (6).
- 8** Fasten the secured handle screw (B) to the handle shell (A) while steadying the knurled nut (5).
- 9** Insert two screws (D) with the discs and fasten them.

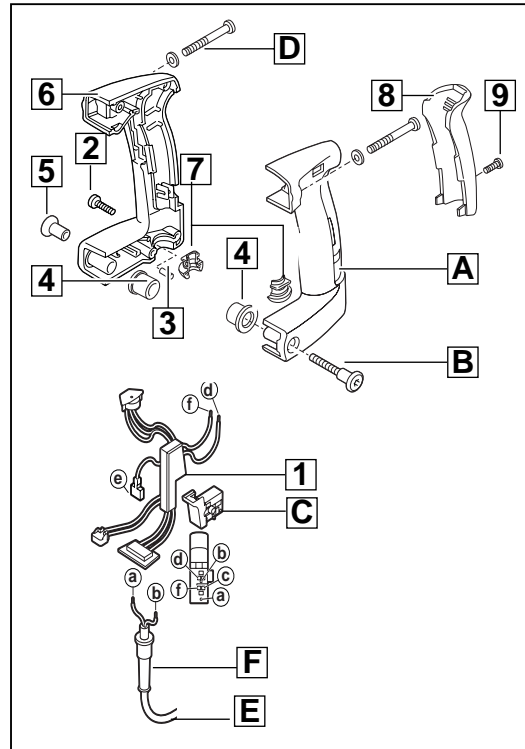

8

**Wiring diagram**

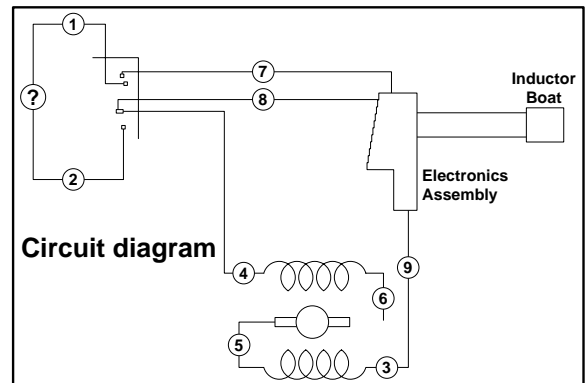
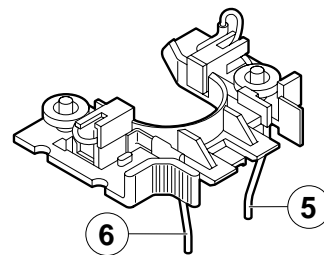
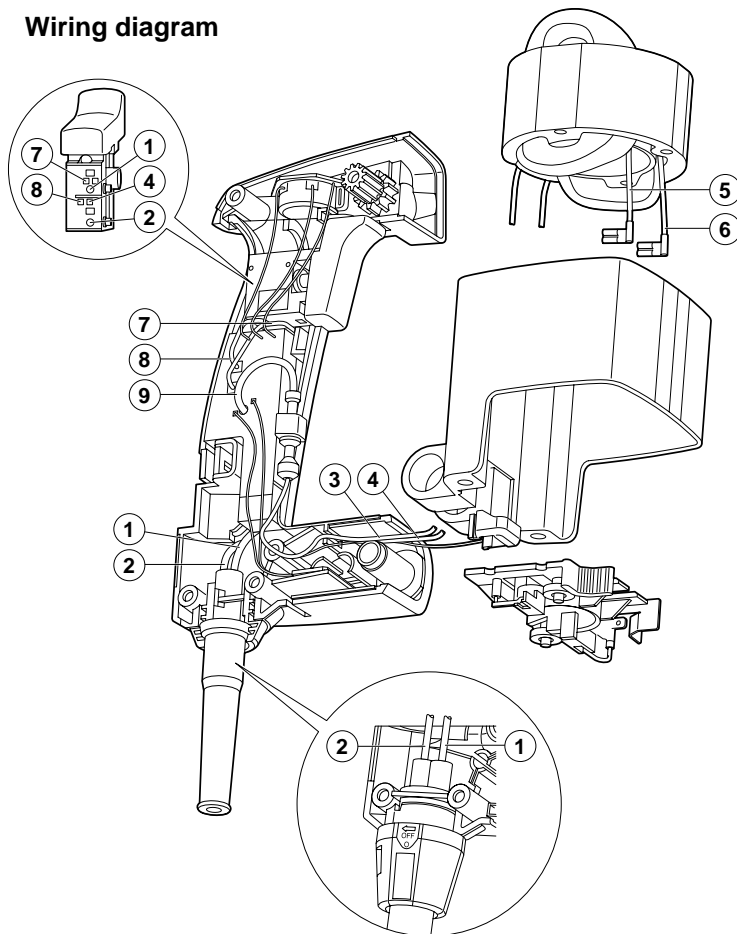

Wire No.	Wire Colour			from	to
	110 V	120 V	230 V		
1	blue	white	blue	mains	switch
2	brown	black	brown	mains	switch
3	red	red	red	field	guide 9
4	red	red	red	field	switch
5	yellow	yellow	yellow	field	brush holder
6	black	black	black	black	brush holder
7	white	black	black	motor control	switch
8	black	black	black	motor control	switch
9	black	blue	red	motor control	guide 3

**Mounting the armature**

- 1** Push the plug (5) over the armature (6) and press the fan (7) onto the armature (6). Press the ball bearing (8) as well as the ball bearing (4) over the armature. Push the bearing bush (9) over the ball bearing (8).
- 2** Insert the armature (6) completely with the fan (7) into the motor housing (3) by turning and at the same time depressing it.
- 3** Insert the brush holder (E) into the motor housing from the side (3) (mind the right position!) and fasten them.
- 4** Insert the carbon brushes (D) with the cable lugs (1) and (C) into the brush holder (E).
- 5** Connect the cable lugs (1) and (C) with the field.
- 6** Mount the brush springs (2) in the brush holder (E). Pull the brush springs (2) aside at their hooks and pull them over the carbon brushes (D).
- 7** Fit the motor housing cap (A) and fasten it with the four secured screws (B).

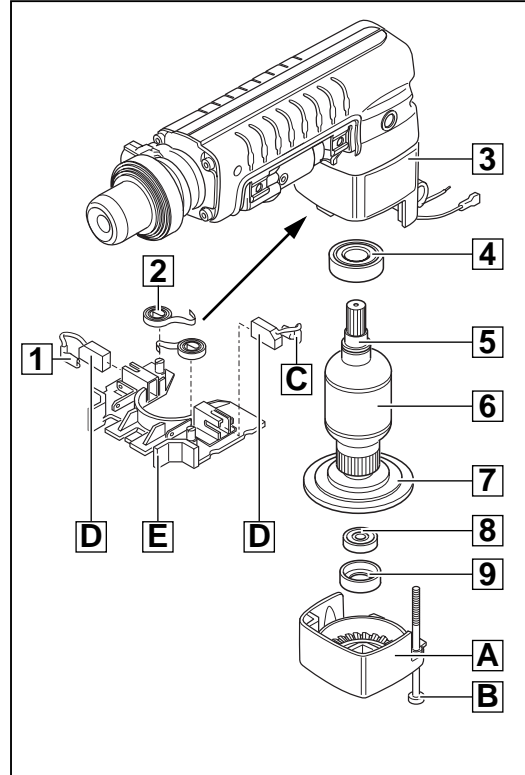

9

**Mounting the switch knob**

- 1** Fit the torsion spring (8) to the shift pin (7) such that it is located in the boring of the shift pin (7).
  - 2** Insert the shift pin (7) with the torsion spring (8) into the gear box insulation (3).
  - 3** Mount the ball (2), the pressure spring (1) and the switch knob (9) from the outside in the gear box insulation (3).
  - 4** Insert the O-ring (5) into the gear box insulation (3) and mount the locking ring (4) with aid of special pliers.
  - 5** Fit the gear box insulation (3) to the machine and secure it with the four screws (6).
- ☞ Take care that the pin (7) grasps the groove in the indexing sleeve (D) (see page 7, ill. 2, part (D)).

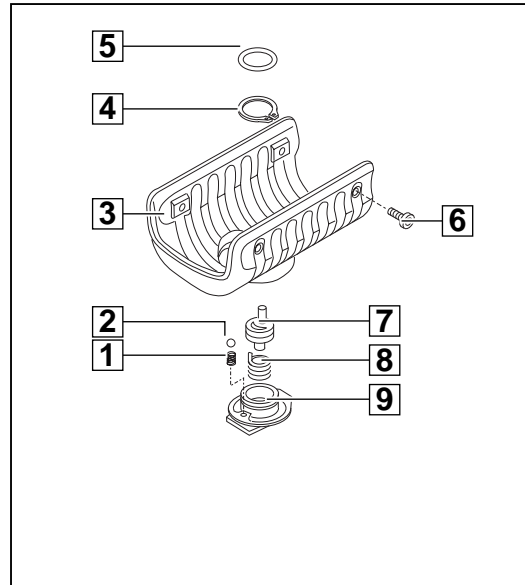

10

**Mounting the holding grip**

- 1 Push the clamping plate (5) over the neck of the machine.
- 2 Insert the nut (6) into the clamping plate (5).
- 3 Push the pin (4) through the clamping plate (5) and the nut (6).
- 4 Fit the plastic holder (7) to the machine and secure it with the O-ring (8) and the locking ring (9).
- 5 Screw down the holding grip (1).
- 6 Push the holding device (3) over the depth gauge (2).
- 7 Fit the depth gauge (2) with the holding device (3) to the machine (see arrow in illustration).

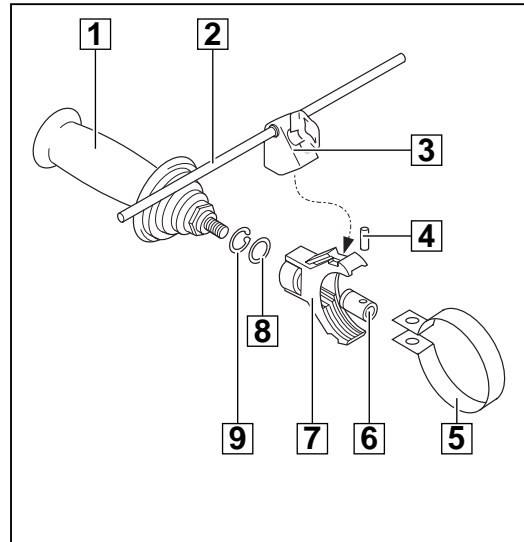

11

**Test Run**

Test run the machine and pay attention to noises.  
Let the machine run-in.

**Electrical Test**

Perform an electrical test on the machine (see chapter Electrical and Mechanical Test Instructions).