

Опубликовано на сайте [www.rem-5.ru](http://www.rem-5.ru)

**Special Tools  
Require**

- |                        |              |
|------------------------|--------------|
| ■ Cone                 | 4931 599 089 |
| ■ Forcing disks        | 4931 599 018 |
| ■ (Dis-) Assembly tool | 4931 599 011 |
| ■ Allen key, long      | 4931 599 010 |

**Important!**

- Before beginning the maintenance work, perform an initial check with a high voltage test according to VDE (see chapter Electrical and Mechanical Test Instructions).
- Before all repair work, pull the power plug from the socket!
- Before dismantling, the machine must be connected to RTR-READER (maintenance measuring instrument) to check for a possible maintenance interval.

**Disassembly****Detaching  
the trigger**

- 1 Loosen the screw (8) and remove the trigger (7) with cover.
- 2 Loosen both screws (1) and remove the motor cover (2).
- 3 Loosen the screws (3) and (5) and the distance sleeve (6).
- 4 Remove the complete handle (4).

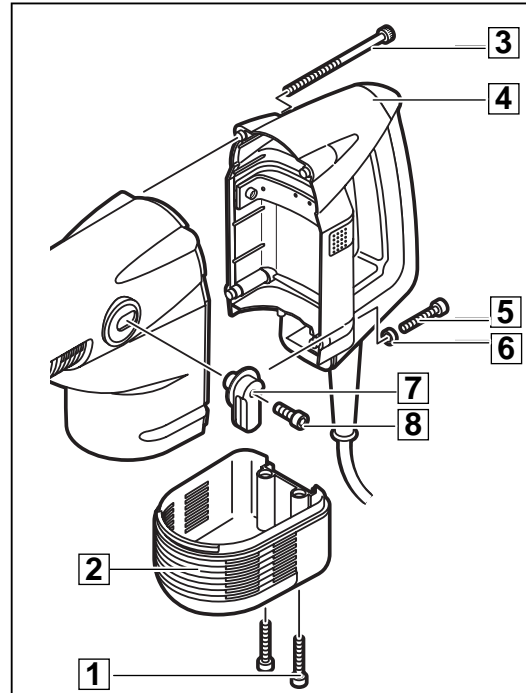

1

**Dismantling the  
auxiliary handle**

- 1 Loosen the screw (2), remove the fan type lock washer (1) and unscrew the handle (3).
- 2 The following parts must be removed:
  - screw off the clamping ring (4)
  - support (5)
  - push out the plastic cover (8),
  - screw (7),
  - clamping ring (6),
  - depth gauge (9).
- 3 Push back the sleeve (B) and lever off the cover cap (A).
- 4 Remove the sleeve (B).
- 5 Pull the gear housing insulation (C) from the machine.

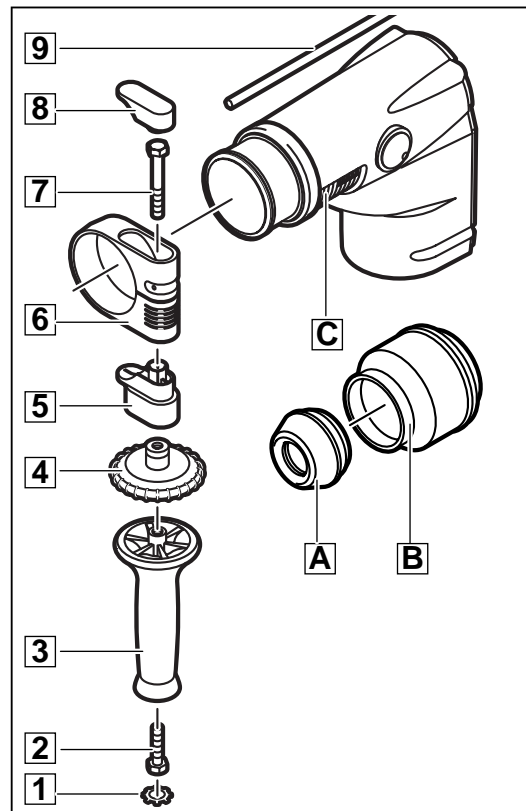

2

**Detaching the electric components and the Softgrip**

- 1 On both sides, loosen the screws (4) and remove the cover (3).
- 2 Loosen the screw (A).
- 3 Lever off the Softgrip (8) from above since it is fitted at the top (see arrow in illustration).
- 4 Loosen the screws (6) and detach the cable clamp (5).
- 5 Lay bare the connection cable (9) with the switch (7). Branch off the connection cable from the switch (7). Pull the cable clamp off the switch (7).
- 6 Loosen the screw (1) and detach the service LED-module (2).

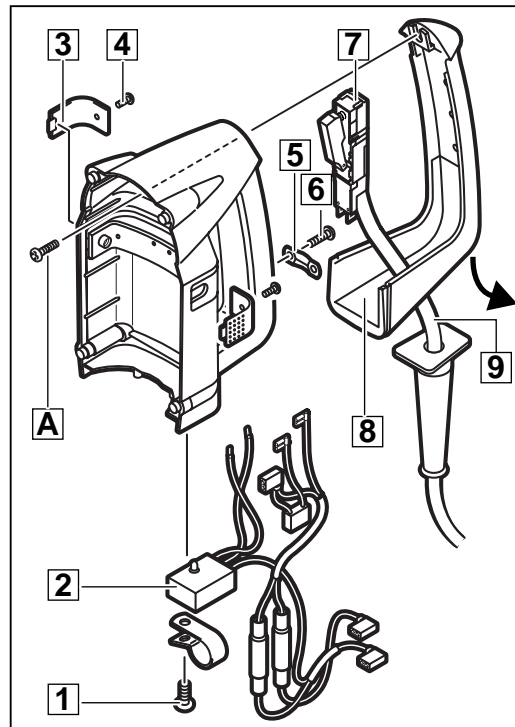

3

**Detaching the locking elements**

- 1 Remove the spring ring (1) with aid of special pliers. If necessary, use a screwdriver for support.
- 2 Remove the stop (2) and the damper ring (3).
- 3 Remove the retainer (4).
- 4 Push in the plate (5) against resilience - the locking elements (6) are relieved. Unscrew and remove the locking elements (6).
- 5 Relieve the plate (5) and remove the pressure spring (7).
- 6 Rotate the machine by 90° to remove the disc (8) (the disc (8) will fall out).
- 7 Remove the bearing sleeve (9) and the O-ring (A).

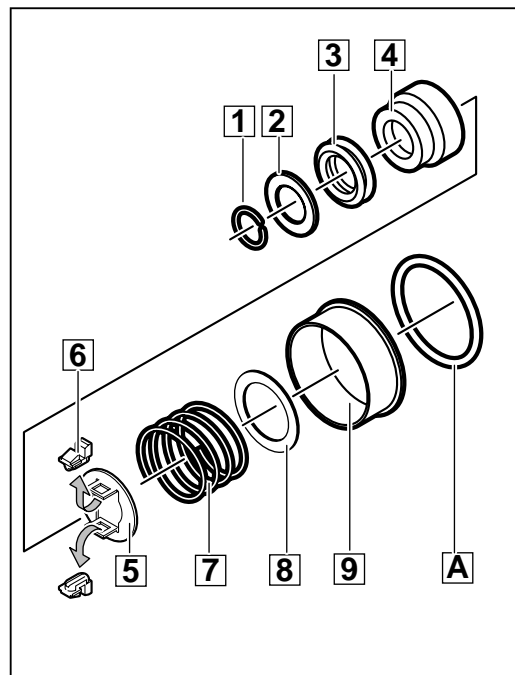

4

**Removing the field and the armature,**

**1** Pull off the respective cable lugs (1) and remove the carbon brushes (2) on both sides by lifting the carbon brush springs.

**Removing the gear cover**

**2** Loosen the screws (A) and detach the brush holders (3).

**3** Loosen the four screws (4).

**4** Remove the field together with the motor housing (9). The armature (5) will remain in the gear cover (6).

**5** Remove the O-ring (B) from the rubber sleeve of the armature bearing. Pull out the armature (5) manually, if necessary use a plastic hammer for support (light blows).

**6** Undo the two screws (7) in the gear cover (6) and pull off the gear cover (6). If needed, remove it with blows with a plastic hammer.

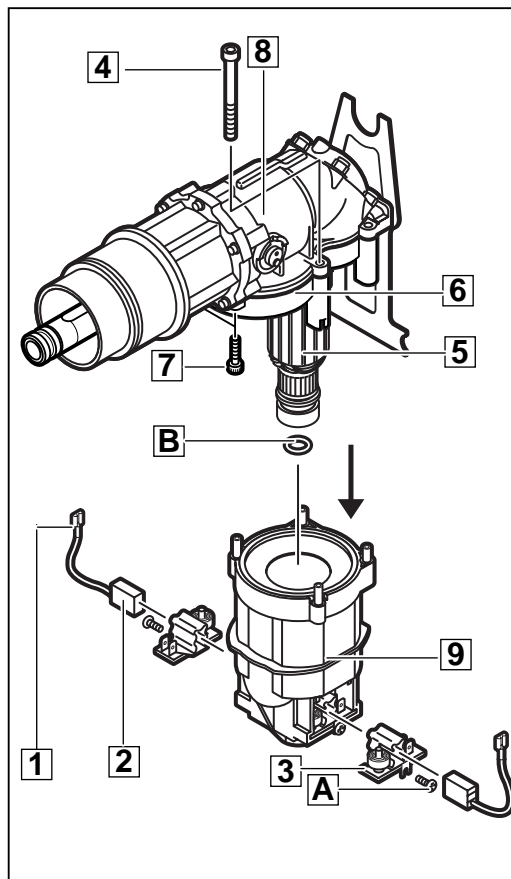

5

**Removing the complete sleeve**

**1** Remove the two springs (5) and (6), the spring ring (7), the actuator (8) and the O-ring (9).

**2** Remove the five screws (3) with their washers and pull the housing (4) from the gear housing (B) (the screws are stuck in).

**3** Remove the complete spindle sleeve (A). Remove the O-ring (C).

**4** Loosen both screws (1) and remove the spring (2).

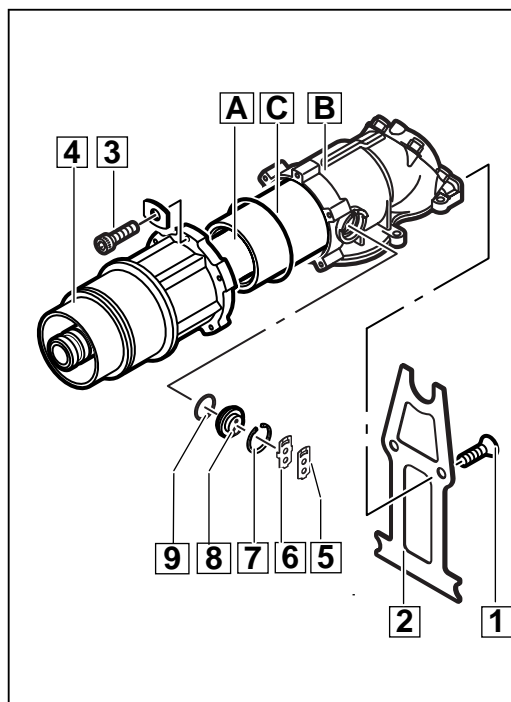

6

**Dismantling  
the sleeve**

- 1** Remove the locking ring (1) and the retaining ring (2).

---

- 2** Remove the six balls (4) with aid of a magnet from the drill spindle (3) and pull the drill spindle (3) from the spindle sleeve (F).

---

- 3** Remove the anvil (7) from the drill spindle (3) and remove the seals (8) from the anvil (7).  
Expel the distance sleeve (6) from the drill spindle (3) with aid of a screwdriver (apply it at the side through the groove).  
Remove the O-ring (5) from the drill spindle (3).

---

- 4** Remove the following parts from the spindle sleeve (F):  
ring (9),  
rubber ring (A),  
ring (B).

---

- 5** Remove the O-ring (C) and the locking ring (D) from the spindle sleeve (F), and press off the ball bearing (E) with aid of a service tool.

---

- 6** Remove the striker (U) from the spindle sleeve (F) and remove the O-ring (V) from the striker (U).

---

- 7** Detach the locking ring (T) from the spindle sleeve (F).  
Remove the following parts:  
driver (S),  
sleeve (M),  
spring (L),  
spring ring (K),  
sleeve (I),  
washer (H),  
sleeve (G).

---

- 8** Remove the ring (R) from the driver (S).

---

- 9** Remove the following parts from the sleeve (M):  
locking ring (Q),  
discs (N), (P),  
sleeve (O).

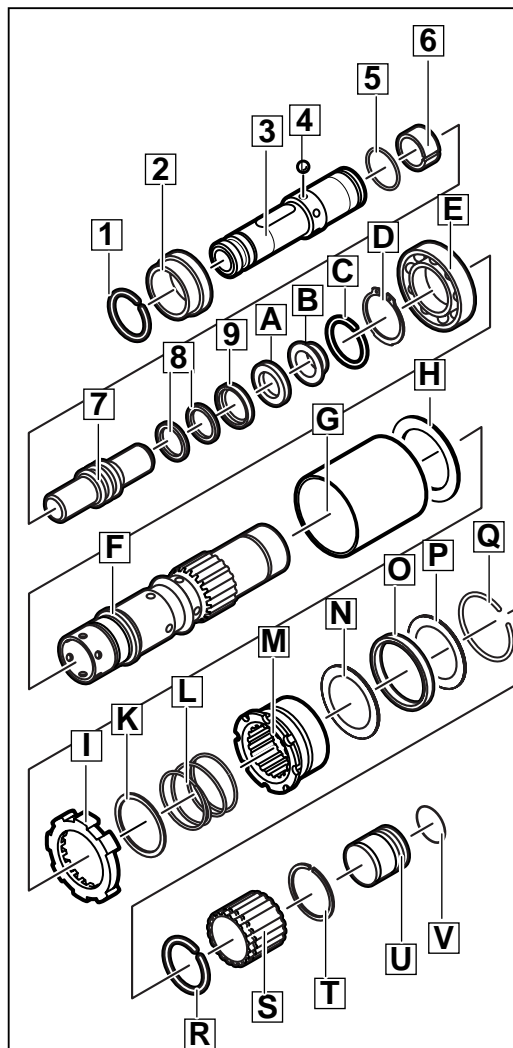

7

**Detaching  
the armature**

- 1 Pull the rubber sleeve (1) and the bearing ring (6) from the armature (4).
- 2 Press off the bearings (5) and (2) with aid of the forcing discs (service tool). Detach the seal ring (3).

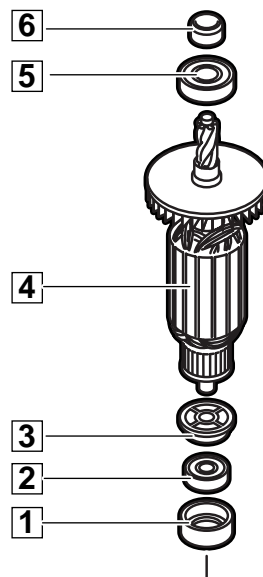

8

**Detaching  
the field**

- 1 Remove the air deflector ring (4) from the motor housing (1).
- 2 Loosen both screws (3) with their washers and expel the field (2) from the motor housing (1).

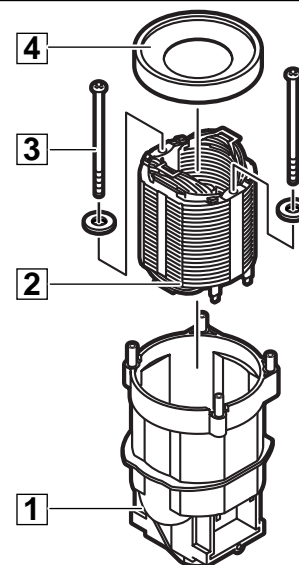

9

**Detaching  
the bearings**

- 1 Remove the O-ring (6) and the fan type lock washer (5) as well as the O-ring (3) from the gear cover (1).
- 2 Pull out the bearings (2) and (4) with aid of an interior extractor.

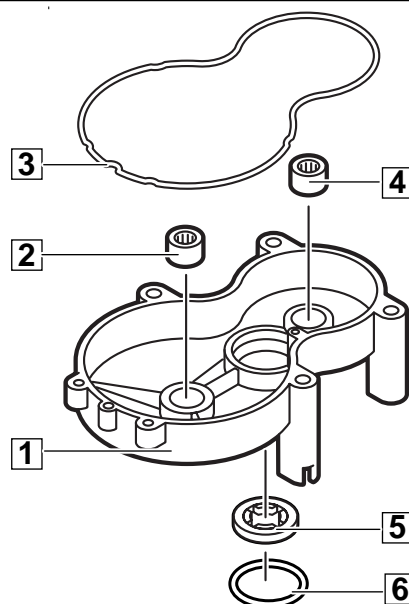

10

**Detaching the crank**

- 1 Apply specially cut pliers between gear wheel and gear housing (3) to remove the locking ring (1).
- 2 Remove the complete crank (2) from the gear housing (3).
- 3 Remove the piston and the connecting rod.

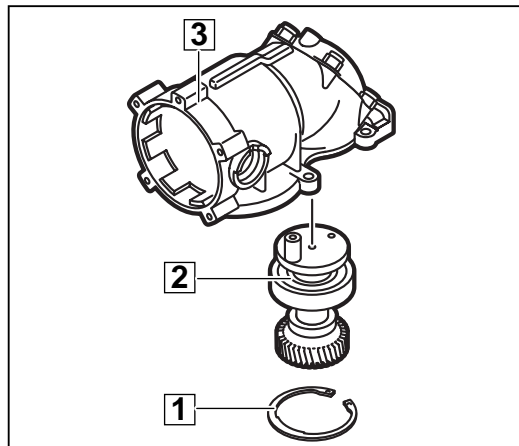

11

**Removing the connecting rod**

- 1 Remove the four-lips-seal-ring (1) from the piston (2).
- 2 Press the bolt (3) from the piston (2) and pull out the connecting rod (5).
- 3 Press the bearing (4) from the connecting rod (5).

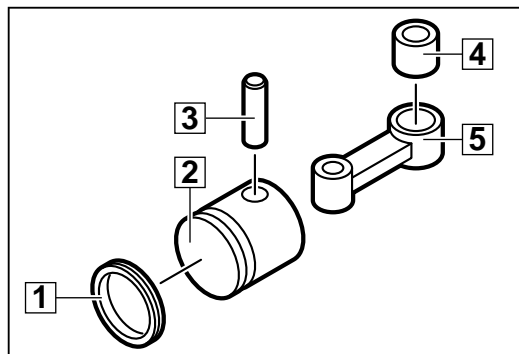

12

**Dismantling the drive**

- 1 Align the drive wheel (4) with the borings of the screws (7). Loosen both screws (7) and remove the complete drive.
- 2 Remove the spring ring (1) with aid of the disassembly tool (service tool), depressing the spring plate (2) at the same time.
- 3 Remove the spring plate (2), friction disc (3), drive wheel (4), friction disc (5), spring plate (6), and spacer (B) from the pinion (A).
- 4 Press off the ball bearing (9) with aid of the forcing discs (service tool).

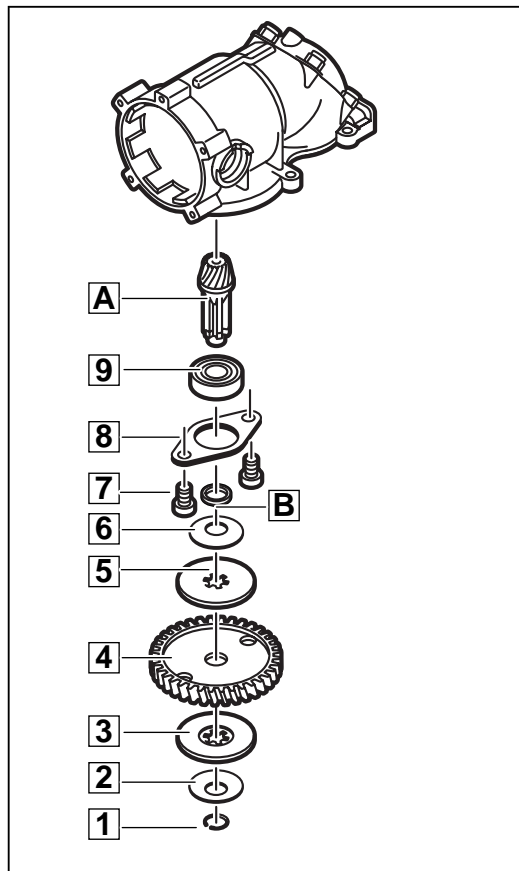

13

**Detaching the  
bevel wheel**

- 1** Remove the bevel wheel (9) and the bearing (8).
- 2** Undo the four nuts (1), remove the washers (2) and detach the cover (3) as well as the gasket (4).  
Remove the felt ring (A).
- 3** Remove the O-rings (5) and (6) and the two pins (7).

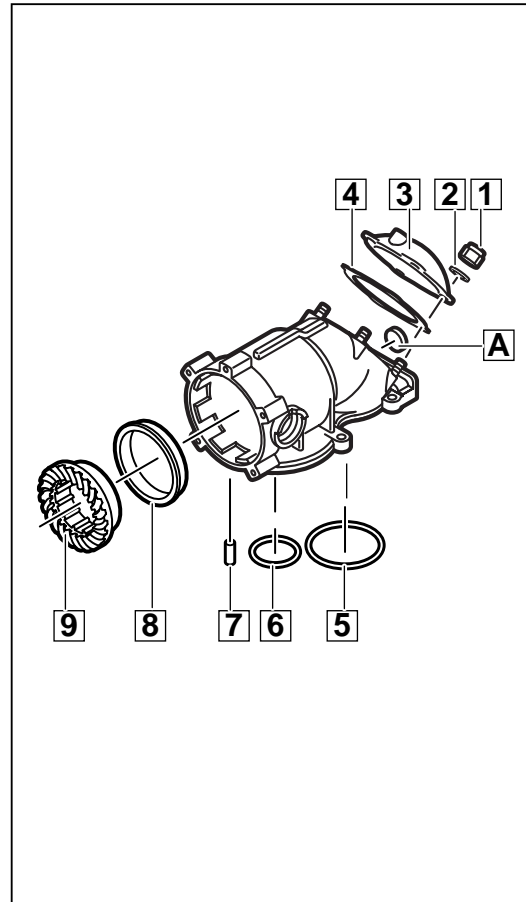

14

**Maintenance**

<b>General</b>	It is recommended to submit the machine to maintenance after the carbon brushes have switched off.
<b>Cleaning</b>	Clean all parts – with the exception of the electrical parts – with cold cleaning agent. Caution! No cleaning agent should penetrate into the bearing. Clean the electrical parts with a dry brush.
<b>Check for wear</b>	Check the disassembled parts for wear (visual inspection) and replace worn parts.
<b>Electrical tests</b>	Before reassembling, perform an electrical test on all relevant parts (see chapter Electrical and Mechanical Test Instructions).
<b>Lubrication</b>	Each time maintenance is performed, the machine is to be lubricated as stated in the lubrication plan. After the machine is fully disassembled, completely remove the old grease and replace with new grease. The grease must be applied to the machine as indicated in the lubrication plan.



**Legend**

**A** Cover with grease DARINA (total of 50 g) (4931 622 229)

**B** Cover with blue grease Mobilith HP 222 (40 g total) (9170 304 322)

**C** Cover with Tivela Compound A (10 g) (493170 215 436)

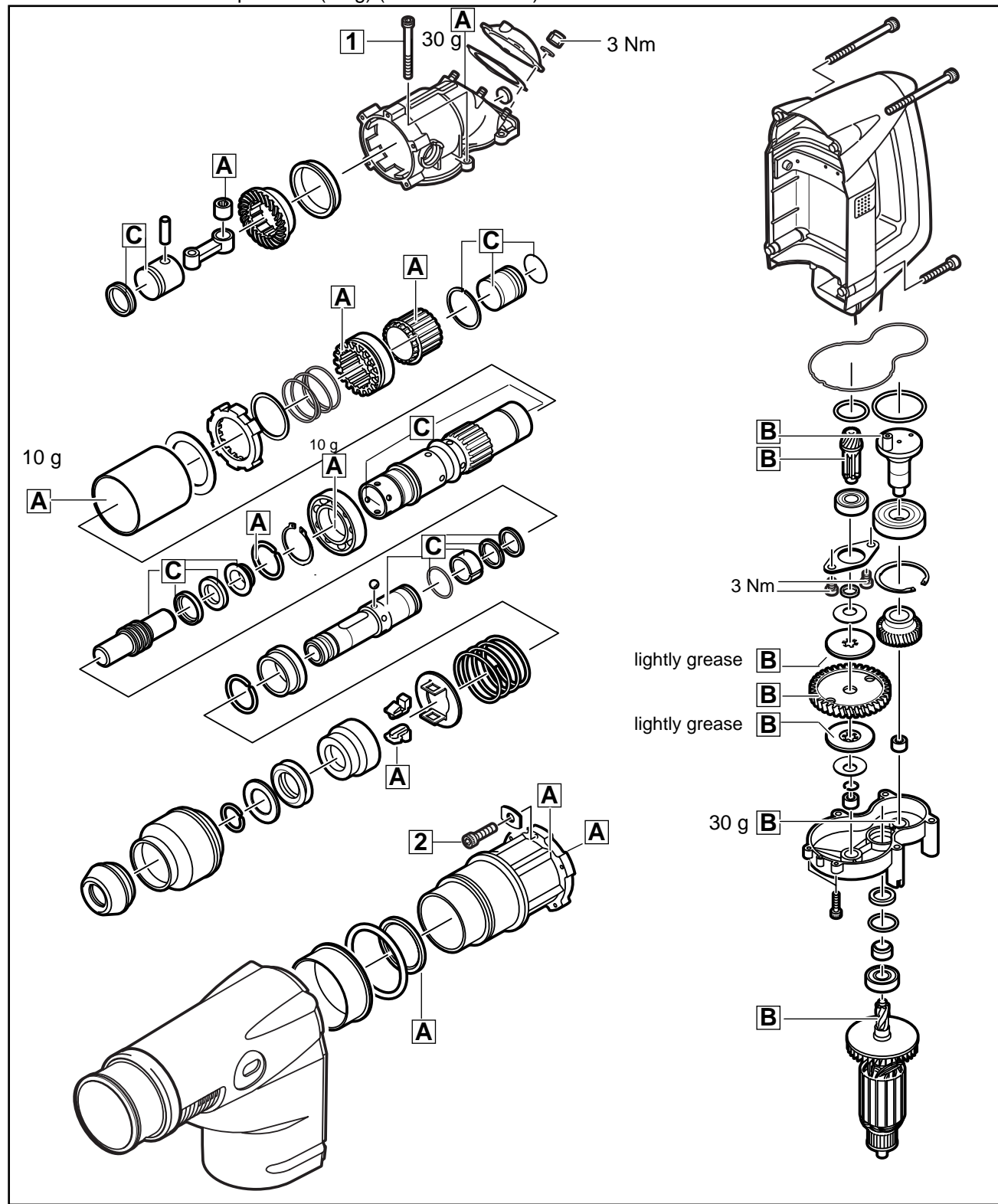

Torques		
	Screws in plastic	1,5 Nm
	Screws in metal	4,0 Nm
	Motor housing screws (1)	4,0 Nm
	Flange screws gear (2)	10,0 Nm

**Screw locking device**

Secure all screws with locking device Loctite 222.

## Assembly

### Mounting the bevel wheel

- 1 Press the bearing (2) flush into the gear housing (6). Press the bevel wheel (1) into the bearing (2).
- 2 Mount the O-rings (4) and (5) and press in the two pins (3).
- 3 Insert the O-ring (7) into the groove of the gear housing.

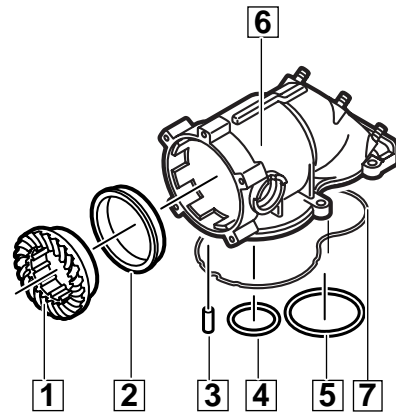

1

### Assembling the drive

- 1 Press the ball bearing (9) onto the pinion (A) and mount the following parts one after the other on the pinion (A): spacer (B), plate (8), spring plate (6), friction disc (5), drive wheel (4), friction disc (3), spring plate (2).

 Lightly grease discs (3) and (5) with blue grease, type Mobilith HP 222.

- 2 Mount the spring ring (1), depressing the spring plate (2) at the same time.
- 3 Insert the assembled drive into the gear housing (C) and fix it with screws (7) through the aligned plate (8).

 Cover the screws (7) with screw locking device and tighten with 2 Nm.

 The **safety clutch** can't be adjusted: In case the drill bit does not rotate at low load, please check the spring plates and the clutch discs for wear. If necessary, replace them.

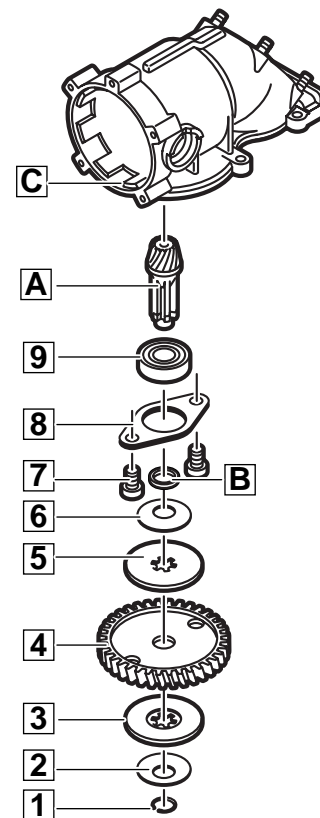

2

### Mounting the connecting rod

- 1 Mount the four-lips-seal-ring (1) to the piston (2).
- 2 Press the bearing (4) into the connecting rod (5).
- 3 Push the connecting rod (5) into the piston (2) and secure it with the bolt (3).

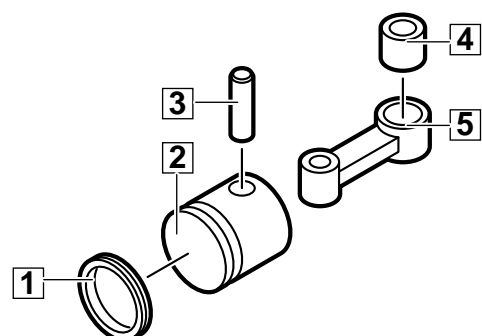

3

**Mounting  
the crank**

- 1 Insert the piston and the connecting rod into the gear housing (3).
- 2 Insert the complete crank (2) into the gear housing (3) from below and hang it in the connecting rod.
- 3 Insert the locking ring (1) with aid of specially cut pliers between toothed wheel and gear housing (3).

 The locking ring (1) must cover the boring (4) (dotted line) to avoid the escaping of any grease.

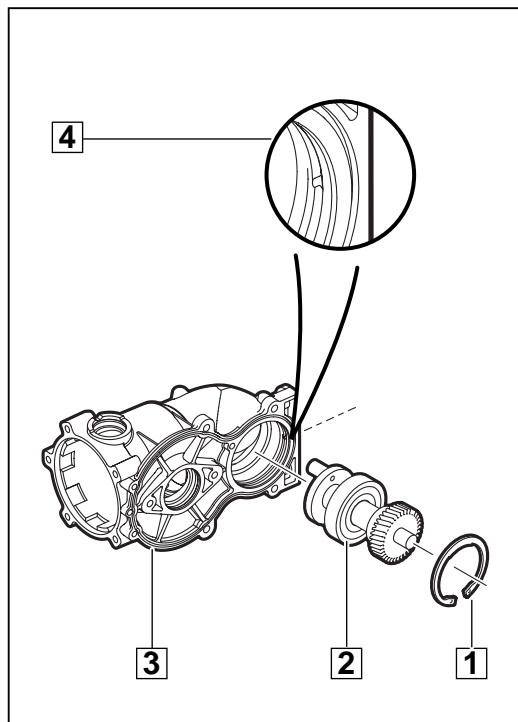

4

**Mounting  
the bearings**

- 1 Press in the bearings (2) and (3).
- 2 Insert the fan type lock washer (4) and the O-ring (5) into the gear cover (1).

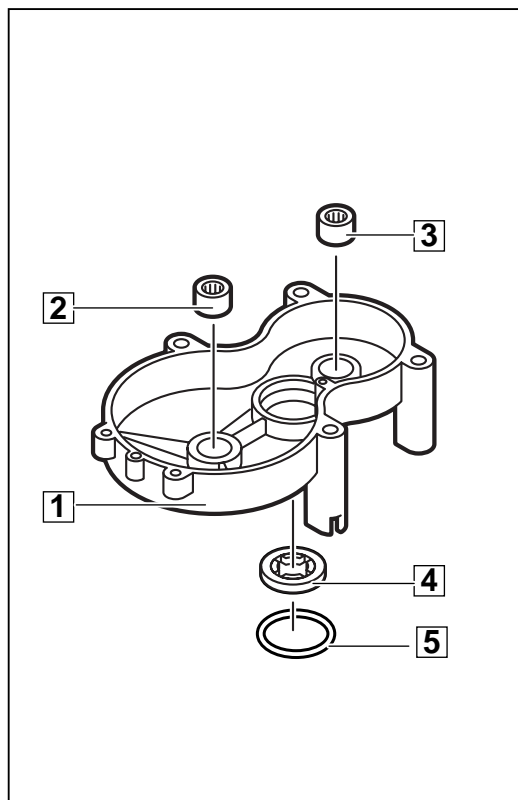

5

**Mounting  
the field**

- 1 Insert the field (2) into the motor housing (1) (mind the right position!) and secure it with screws (3) and washers (tightening moment = 8 Nm).
- 2 Fit the air deflector ring (4) on the motor housing (1).

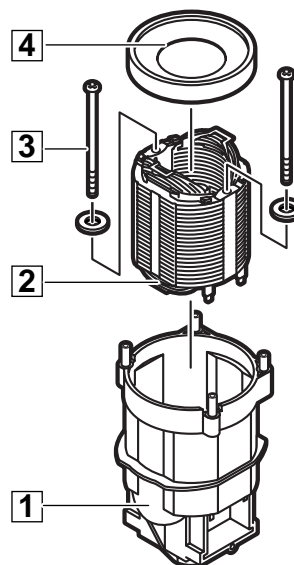

6

**Mounting  
the armature**

- 1 Mount the seal ring (3) on the armature shaft. Press in the bearings (5) and (2).
- 2 Mount the rubber sleeve (1) and the bearing ring (6) on the armature shaft (4).

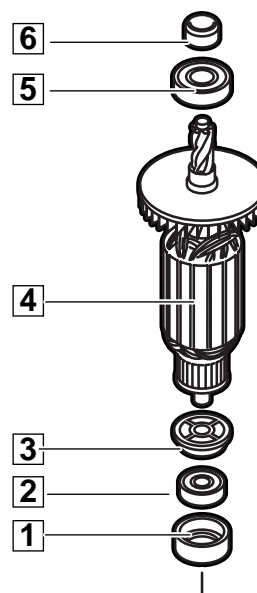

7

**Assembling  
the sleeve**

- 1** Press the ball bearing (E) onto the spindle sleeve (F) and fit the locking ring (D) and the O-ring (C).

---

- 2** Mount the ring (R) on the driver (S).

---

- 3** Mount the following parts on the sleeve (M):  
disc (N),  
sleeve (O),  
disc (P).  
Insert the locking ring (Q).

---

- 4** Mount the following parts on the spindle sleeve (F):  
spring ring (K),  
sleeve (G),  
spring (L) (pressed over the tothing of the spindle sleeve (F)),  
washer (H),  
sleeve (I),  
sleeve (M),  
driver (S).

---

- ☞ Mount the locking ring (T) on the spindle sleeve (F) with aid of the cone (service tool).

---

- 5** Mount the O-ring (V) on the striker (U) and insert the striker (U) into the spindle sleeve (F).

---

- ☞ The O-ring (V) must face the direction of the four-lips-seal-ring of the piston.

---

- 6** Insert the ring (B), the rubber ring (A) and the ring (9) into the spindle sleeve (F).

---

- 7** Fit the O-ring (5) on the drill spindle (3), insert the distance sleeve (6) into the drill spindle (3), and fit the seals (8) on the anvil (7).  
Insert the anvil (7) into the drill spindle (3).

---

- 8** Insert the drill spindle (3) into the spindle sleeve (F).  
Insert the six balls (4) with aid of a magnet into the drill spindle (3).

---

- 9** Mount the locking ring (1) and the retaining ring (2) on the drill spindle (3).

---

- ☞ Mind the right position of the locking ring (D) concerning the relieves in the retaining ring (2).

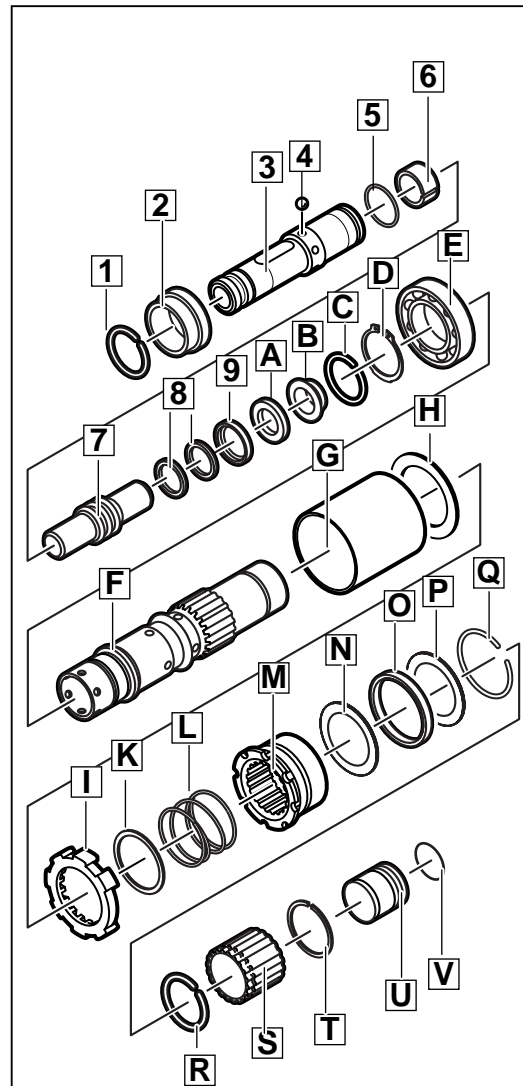

Anvil fitting position:  
The shortened phase faces the drill  
(to the front).

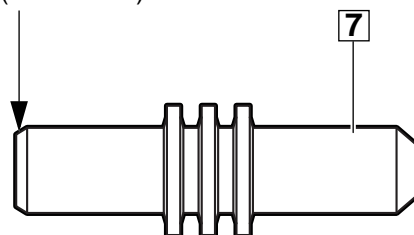

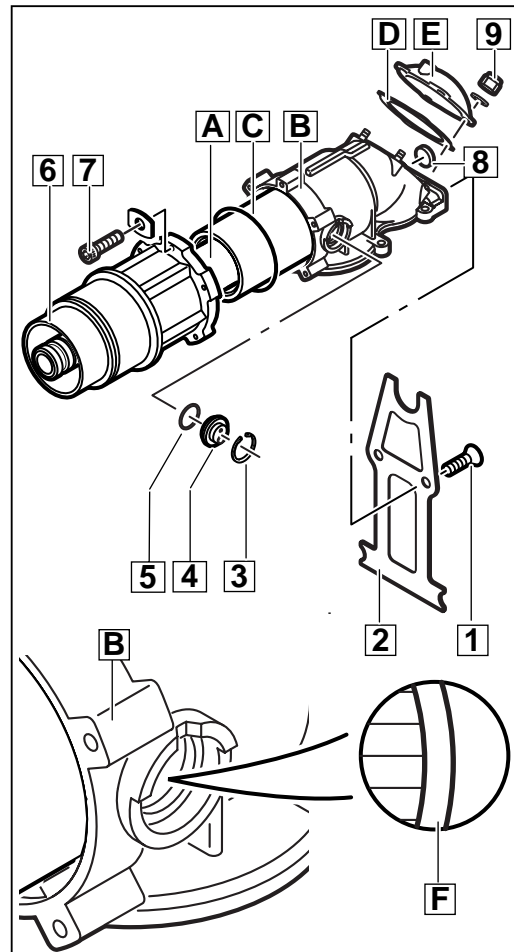

**Mounting the complete sleeve**

- 1 Fasten the spring (2) with the screws (1).
- 2 Insert the complete sleeve (A) into the gear housing (B) and take care that the piston and the sleeve (A) are aligned. If necessary, align the piston centred through the gear housing opening.
- 3 Insert the O-ring (C) into the gear housing.
- 4 Mount the housing (6) on the gear housing (B) and tighten down the five screws (7) with their washers.
- 5 Insert the O-ring (5), the actuator (4), and the spring ring (3).
  -  The actuator (4) must be mounted such that it grasps the groove of the drive sleeve (F).
- 6 Fit the gasket (D) and the cap (E) and fasten it with the 4 nuts (9) (torque = 3 Nm) and the washers.
- 7 Insert the felt (8).



9

**Mounting the gear cover****Mounting the field and the armature**

- 1 Mount the gear cover (6) and fasten it with two screws (7) to the gear housing (8).
  -  The two screws (7) must be covered with screw locking device.
- 2 Push the armature (5), turning it slightly, through the gear cover (6) into the gear.
- 3 Insert the O-ring (B) aligned into the motor housing (9) and mount the field together with the motor housing (9). Mind the right position!
- 4 Fasten the field with the motor housing (9) to the gear cover with four screws (4).
- 5 Mount the brush holders (3) and fix them with the screws (A).
- 6 Carefully lift the carbon brush springs on both sides and insert the carbon brushes (2). Fit the cable lugs (1).
  -  Attention: Mind the mounting position of the flat spiral spring (C): Pre-tension the spring 3/4 turn!

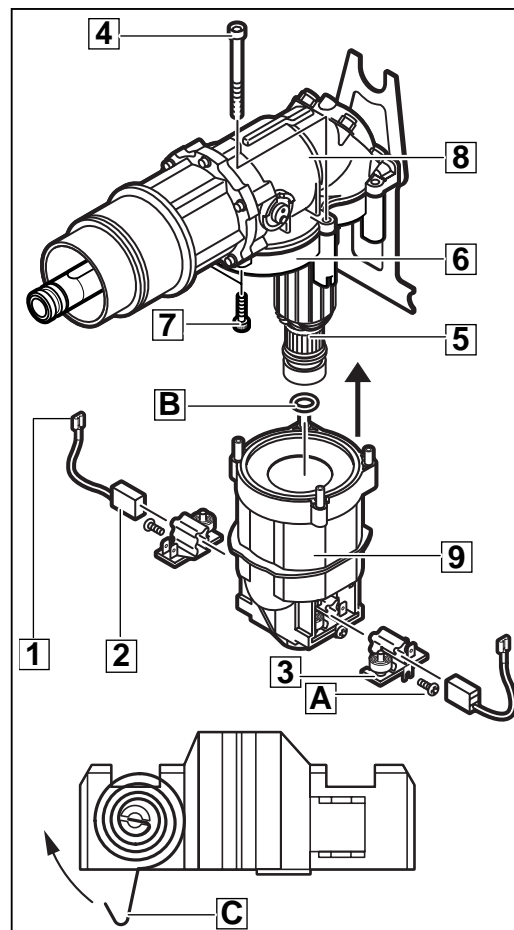

10

**Mounting the locking elements**

- 1 For further assembly, rotate the machine as shown in illustration:  
Push the O-ring (1) and the bearing sleeve (2) over the housing (3).

---

- 2 Place the disc (5) and the pressure spring (6) between housing (3) and spindle sleeve (4).

---

- 3 Place the plate (7) on the pressure spring (6) and depress the latter. Let the locking elements (8) engage in the plate (7) and the spindle sleeve (4).

---

- 4 Fit the retainer (9), the damper ring (A) as well as the stop (B) and secure them with the spring ring (C).

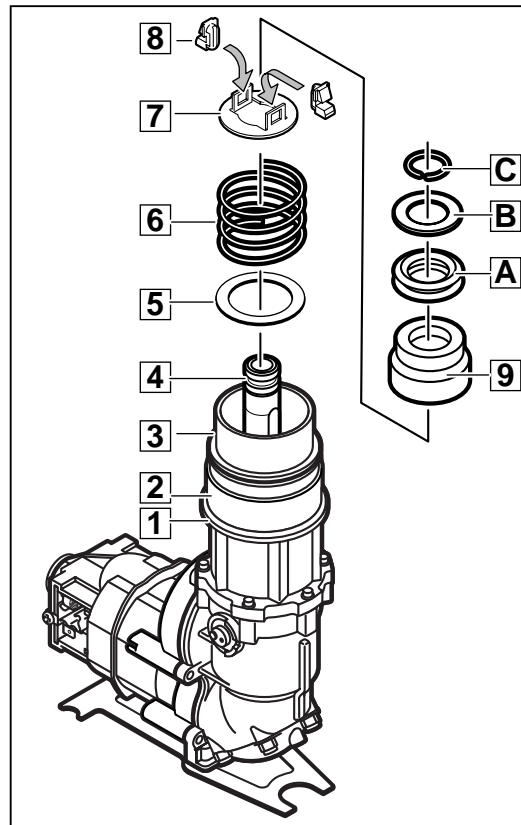

11

**Mounting the trigger,**

➡ **Place the machine on its side on a mat (1.), to prevent the plate springs from falling down!**

**Mounting the handle**

- 1 Place 2 plate springs (1) and (2) on the trigger.
  - ➡ First fit the spring with the side shaping (2) then fit the spring without the side shaping (1). If necessary, break off the side shapings of plate spring (1).

---

- 2 Fit the gear housing insulation (5) to the machine.  
Mount the trigger (4) and secure it with the screw (3). Mind the right position!

---

- 3 Fit the sleeve (6) and push back and press on the end cover cap (7).

---

- 4 The following parts must be mounted:  
clamping ring (A),  
screw (9),  
plastic cover (8),  
support (B),  
clamping ring (C).

---

- 5 Insert the fan type lock washer (F) into the handle (D), fit the screw (E) and screw down the handle (D).

---

- 6 Mount (G) the depth gauge.

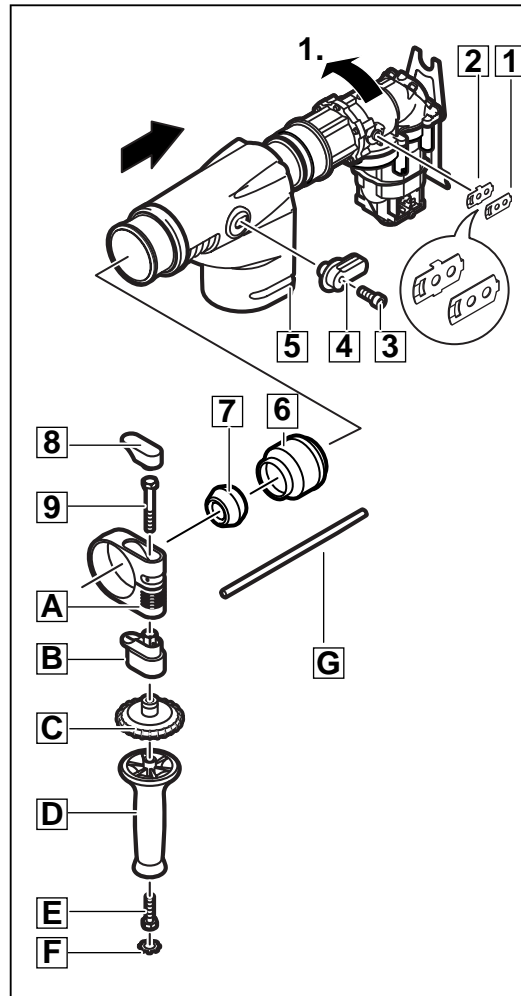

12

**Mounting the electric components and the Softgrip**

- 1 Insert the service LED-module with RTR chip (2) into the housing and fix it with the screw (1).
- 2 Lead the connection cable (9) through the Softgrip (8) and connect the switch (7) with the RTR chip (2).
- 3 Fix the connection cable (9) with aid of the cable clamp (5) and the screw (6).
- 4 Hang up the Softgrip (8) at the top of the handle and press it down.
- 5 Mount the screw (A) to fix the Softgrip (9).
- 6 Fit the cover (3) on both sides and fix it with the screws (4).

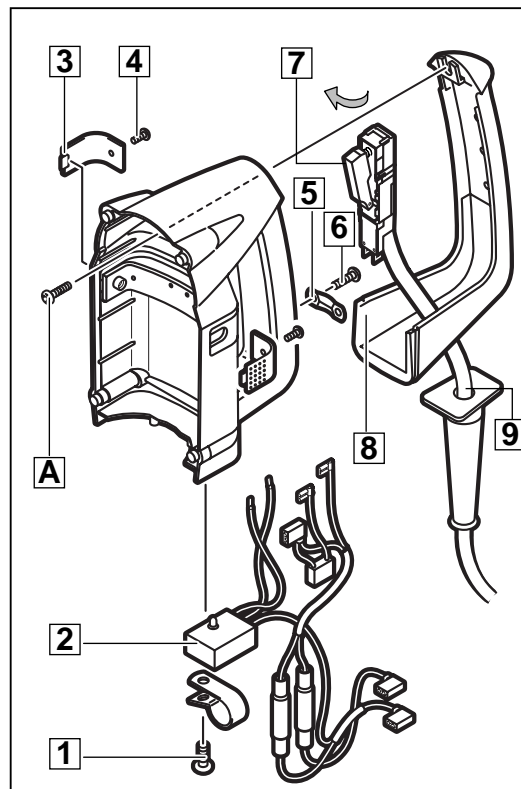

13

**Fastening the complete handle and the motor cover**

- 1 Push the complete handle (4) over the housing and fasten it with the screws (3) and (5) as well as the distance sleeve (6).
- 2 Fix the motor cover (2) with two screws (1).

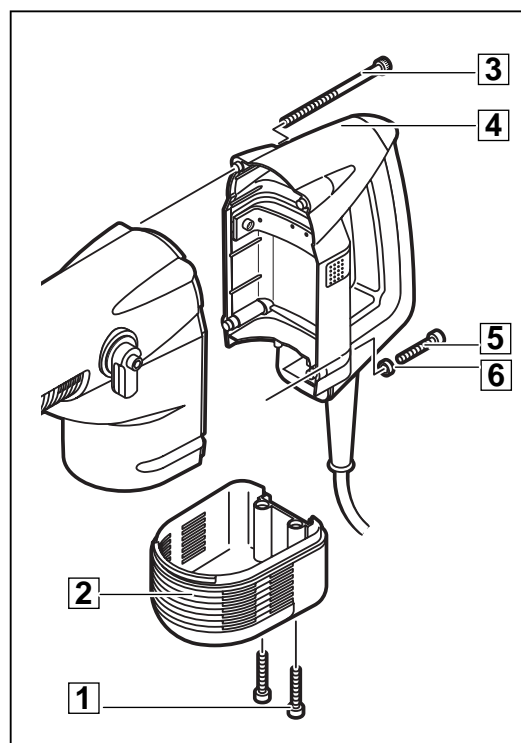

14

**Test Run**

Test run the machine and pay attention to noises.  
Let the machine run-in.

**Electrical Test**

Perform an electrical test on the machine (see chapter Electrical and Mechanical Test Instructions).