

Опубликовано на сайте www.rem-5.ru

Special Tools Required ■ Assembly cone

- Important!**
- Before beginning the maintenance work, perform an initial check with a high voltage test according to VDE (see chapter Electrical and Mechanical Test Instructions).
 - Before all repair work, pull the power plug from the socket!

Disassembly

Dismantling the drill spindle

- 1** Removing the TRITEC chuck from PN 2000 compact TU:
Push the rubber collar aside and remove the holder spring (3) with aid of a mandril. Take care that you don't lose the pin when removing the chuck (4).
- 2** Remove the balls from the drill spindle (1).
 Drill a hole into the sealing ring (5) with a drill bit 3 - 3.5 mm and lever the ring off with aid of a screwdriver.
- 3** Remove the sleeve (2) with aid of special pliers (see illustration).

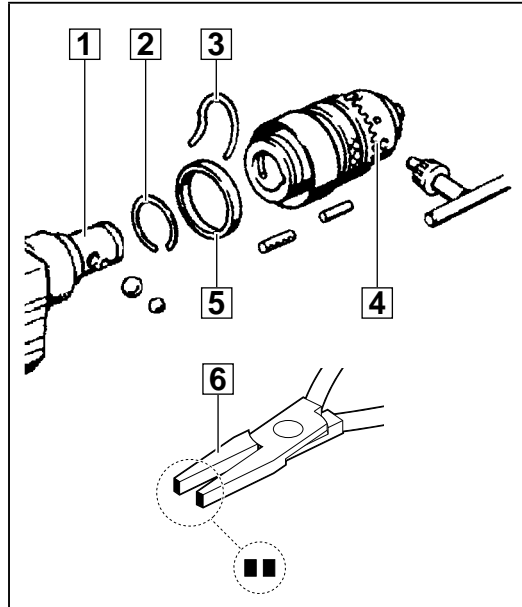

1

Dismantling the gear box

- 1** Remove the spring (3), the discs (4), the teflon-coated disc (5), as well as all the other discs.
 Move the hammer switch lever (1) to the neutral position (30° before drill position).
- 2** Unscrew (6) and remove the gear box (7).
- 3** Remove all disc springs (2).

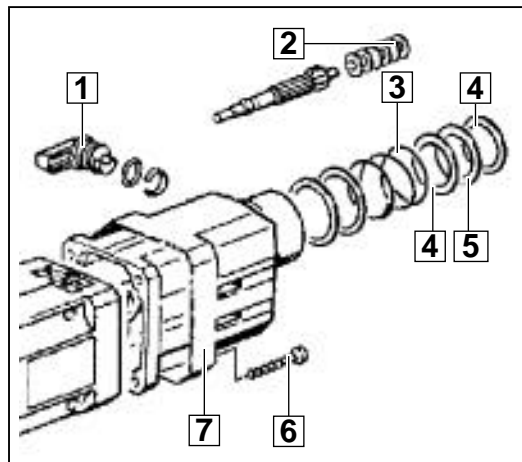

2

Removing the pillow block

- 1** Lift the pillow block (1) and the spring (6) with aid of a screwdriver.
- 2** Remove the drill spindle.
- 3** Remove the cylinder. Remove the percussion body (5) from the cylinder.
- 4** Remove the spring ring (2), the bearing discs, the axial needle bearing (4), the spacer (3), and the disc.

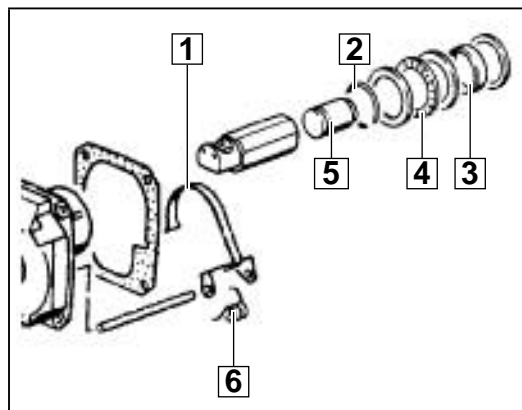

3

Dismantling the wobble gear drive

- 1 Pull up the reduction gear shaft (4) together with the thrust bearing, turn them 90°, and pull the wobble gear drive (2) from the cylinder. Remove the coupling sleeve (5) and the driver (3).
- 2 Remove the reduction gear wheel (1) from the reduction gear shaft with aid of a press.

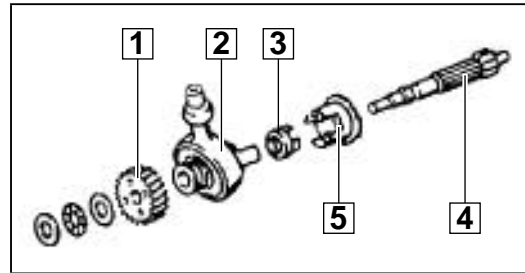

4

Dismantling the bearing end plate

- 1 Remove the bearing end plate (4). If necessary, remove the gasket (3).
- 2 Remove the carbon brushes (1) and the brush holder insulations (2).

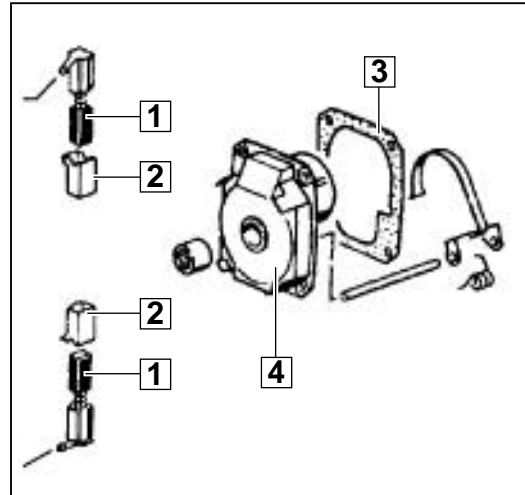

5

Dismantling the handle shells

- 1 Remove the screws from the housing (2).
- 2 Remove and disassemble the armature (4).
- 3 Branch off and remove the field (3).
- 4 Loosen the power supply lead (1) and the other electronic parts and remove them from the housing.

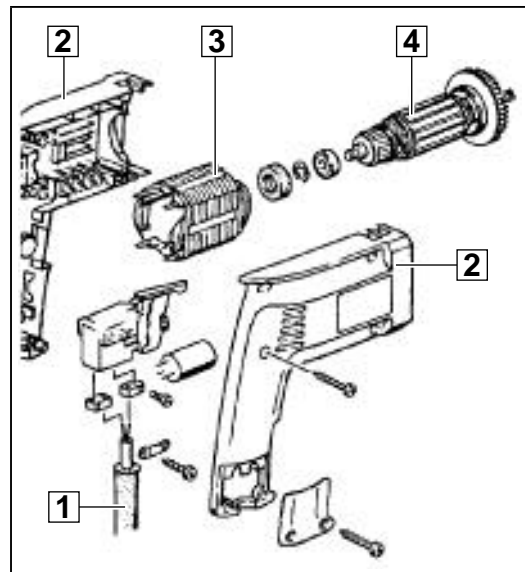

6

Maintenance

General

It is recommended to regularly submit the tool to maintenance, or as soon as the hammer mechanism gets weak, or when the carbon brushes switch off. When carrying out maintenance all parts of the maintenance set must be exchanged. Use the respective maintenance set provided for each machine.

Cleaning

Clean all parts – with the exception of the electrical parts – with cold cleaning agent. **Caution!** No cleaning agent should penetrate into the bearing. Clean the electrical parts with a dry brush.

Check for wear

Check the disassembled parts for wear (visual inspection) and replace worn parts.

Electrical tests

Before reassembling, perform an electrical test on all relevant parts (see chapter Electrical and Mechanical Test Instructions).

Lubrication

Each time maintenance is performed, the machine is to be lubricated as stated in the lubrication plan. After the machine is fully disassembled, completely remove the old grease and replace with new grease. The grease must be applied to the machine as indicated in the lubrication plan.

Legend

- A Cover with grease (6 g Tivela)
- B Cover with grease (15 g Darina)
- C Cover with grease (Darina)

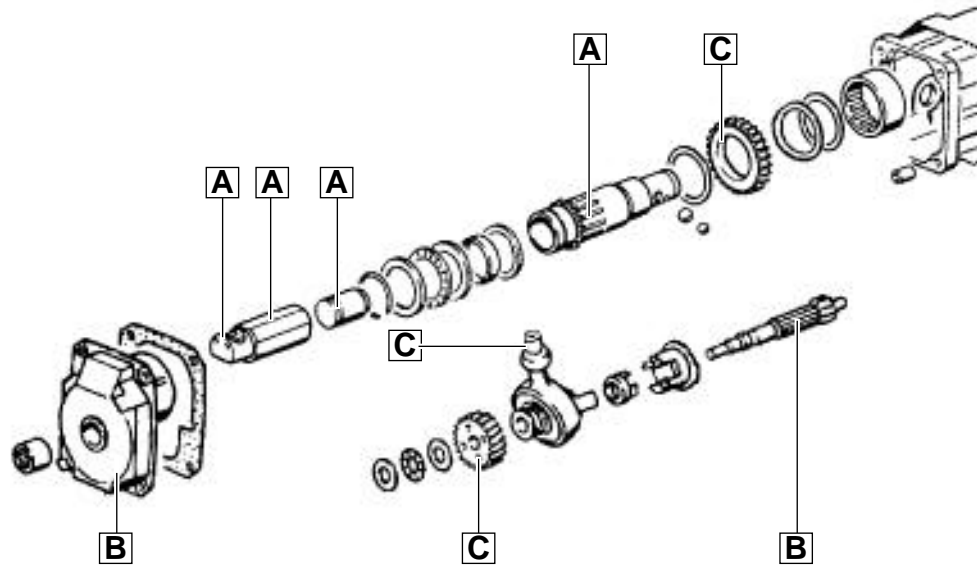

Assembly

Assembling the housing

- 1 Mount the power supply lead (1), the field (3), and all other electronic parts and connect them according to the wiring diagram.
- 2 Insert the armature (4).
- 3 Mount the silicon parts in the housing (2).

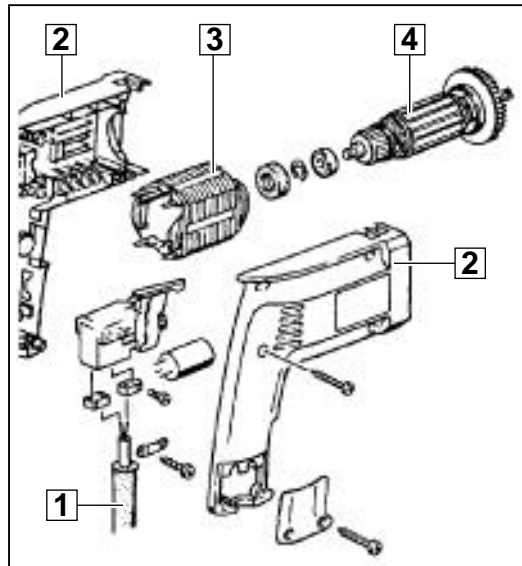

1

Mounting the bearing end plate

- 1 Mount the brush holder insulations (2) and the carbon brushes (1).
- 2 Put together the two housing shells and fasten them with screws.
- 3 Insert the machine into an assembly support.
- 4 Fit the bearing end plate (4) to the motor housing.
- 5 Fit a new gasket (3).
- 6 Insert the percussion body cylinder such that the dented side faces up.

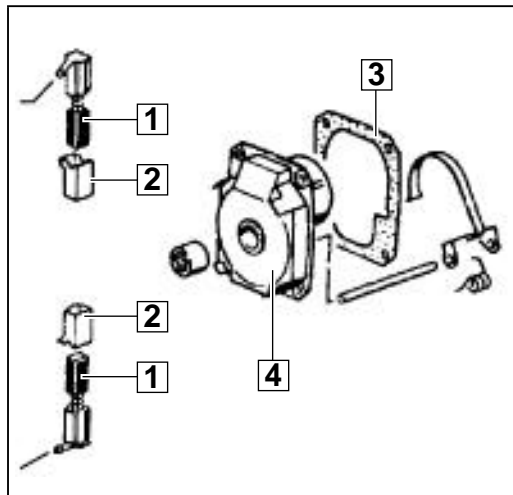

2

Assembling the wobble gear drive

- 1 Fit the coupling sleeve (5) to the reduction gear shaft (4).
 ➔ Press on the reduction gear wheel (1) with **the smooth side** facing the wobble gear drive (2). The end play must be $0.05 + 0.03$ mm.
- 2 Mount the complete reduction gear.

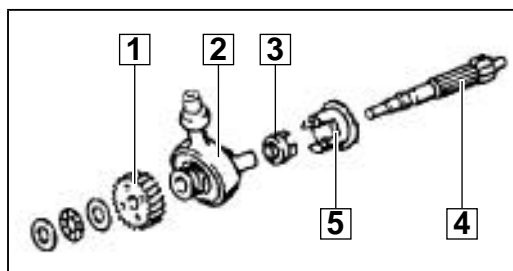

3

Mounting the pillow block

- 1 Mount the spring disc (2), the bearing washers (3), the axial needle bearing (6), the spacer (5), and the disc (4).
- 2 Insert the percussion body (7) into the cylinder.
- 3 Hang up the spring (8) as shown in illustration and insert it into the drill spindle reception with aid of a screwdriver.
- 4 Hold the pillow block (1) back with a screwdriver and fit the drill spindle.
- 5 The reduction gear wheel must grasp the groove in the drill spindle.

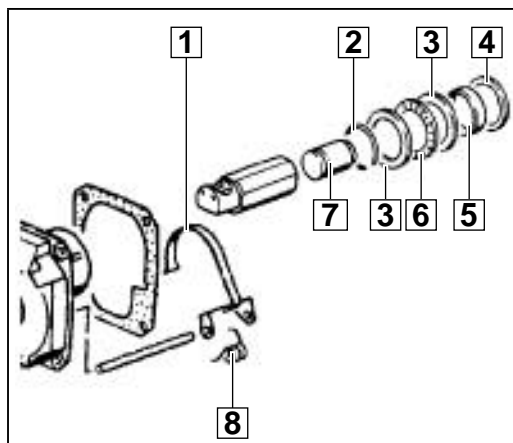

4

Mounting the gear box

- 1 Mount the six disc springs (2) opposite each other (see illustration).
- 2 Fasten the gear boy (7) with screws (6).
- 3 Move the hammer switch lever (1) to the neutral position (30° before drill position).
- 4 Fit the mounting cone (8) (see illustration).
- 5 Insert the spring (3), the discs (4), the teflon-coated disc (5), as well as the other discs.

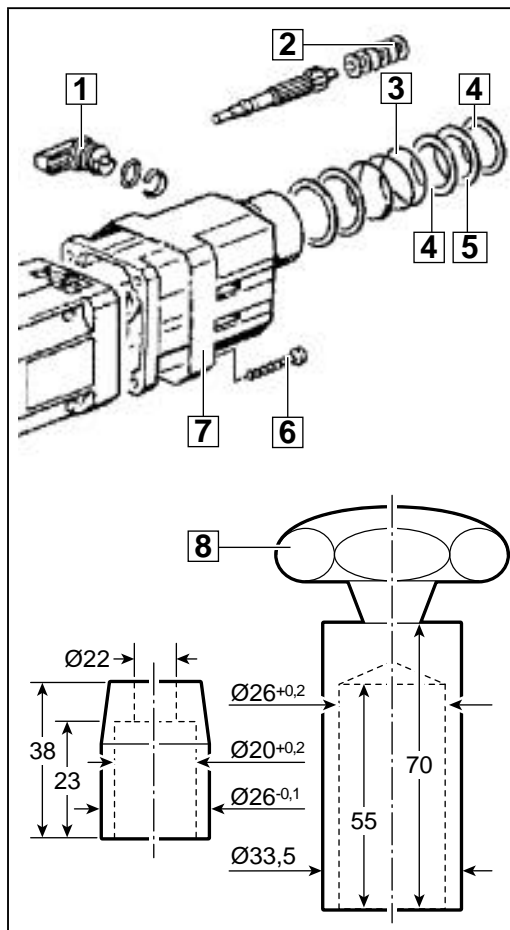

5

Assembling the drill spindle

- 1 Mount the sleeve (2).
- 2 Fit the sealing ring (3) with aid of a mounting cone. The locating distance must be 3.5 ± 0.2 mm.
- 3 Insert two balls into the drill spindle (1).
- 4 Mounting the TRITEC chuck to PN 2000 compact TU:
Insert the pin into the provided boring in the chuck (4). Push the chuck (4) onto the drill spindle such that the pin can be pushed into the groove at the drill spindle. Fix the chuck and insert the holder spring (3) into the provided boring at the chuck and bear it in with a hammer. Push the rubber collar over the holder spring.

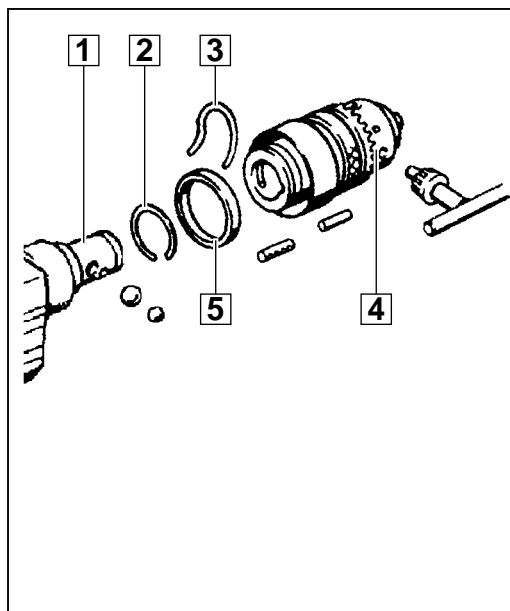

6

Test Run

Check the direction of rotation!
Let the machine run-in.

Electrical Test

Perform an electrical test on the machine (see chapter Electrical and Mechanical Test Instructions).