

Опубликовано на сайте [www.rem-5.ru](http://www.rem-5.ru)

**PN 3500 X**

**Special Tools  
Require**

■ Forcing disks	4931 599 021
■ Special pliers	4931 599 057
■ (Dis-) Assembly tool	4931 5990 84
■ Sleeve	4931 599 038
■ Screw locking agent Omnifit 80	4931 945 651
■ Mounting stand	4931 599 039

**Important!**

- Before beginning the maintenance work, perform an initial check with a high voltage test according to VDE (see chapter Electrical and Mechanical Test Instructions).
- Before all repair work, pull the power plug from the socket!

**Disassembly****Removing the  
carbon brushes**

- 1 Loosen the two screws (6) on both sides and remove the respective service covers (5).
- 2 Remove the cables (3) and pull the brush holders (4) from the housing.
- 3 Put the springs (1) aside (see illustration) and pull out the carbon brushes (2).
- 4 Pull the carbon brush cables together with the carbon brushes (2) from the housing.

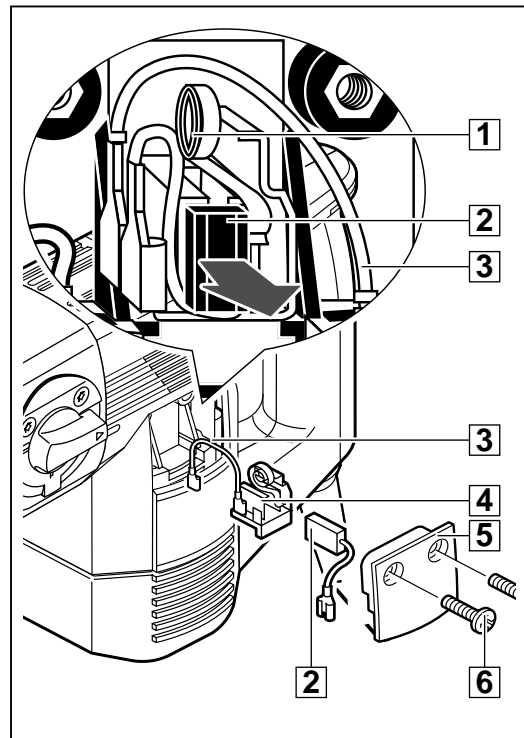

1

**Dismantling the  
FIXTEC-recep-  
tion**

- 1 Remove the locking ring (4).
- 2 Removing the locking sleeve (2):  
  - ☞ Fix the locking sleeve (2) in a pulling-off device (3) and press it out. At the same time, press down the spindle (1) with a suitable sleeve.
  - Or:** Cut the locking sleeve (2) at the side.
- 3 To remove the balls (5) (six pieces):  
  - ☞ Depress the seal ring (6) and remove the balls with aid of a magnet.
- 4 Remove the remaining parts:  
  - seal ring (6),
  - pressure spring (7),
  - disc (8).

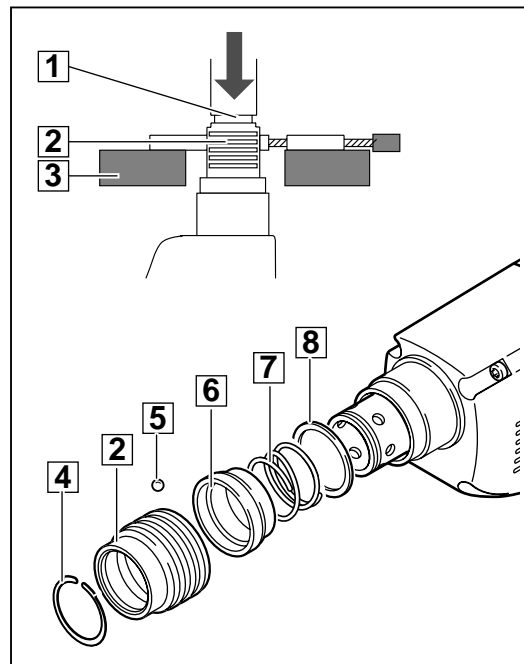

2

**Detaching the gear housing**

- 1 Remove two screws (5) from the holding-down device (6) and lever off the switch lever (4) with aid of a screwdriver.
- 2 Remove the four housing screws (1).
- 3  
 Vertically insert the machine into a mounting stand (4931 599 039).
- 4 Open the locking ring (2) on the spindle with aid of special pliers (7) (service tool) and remove it together with the gear housing (3).

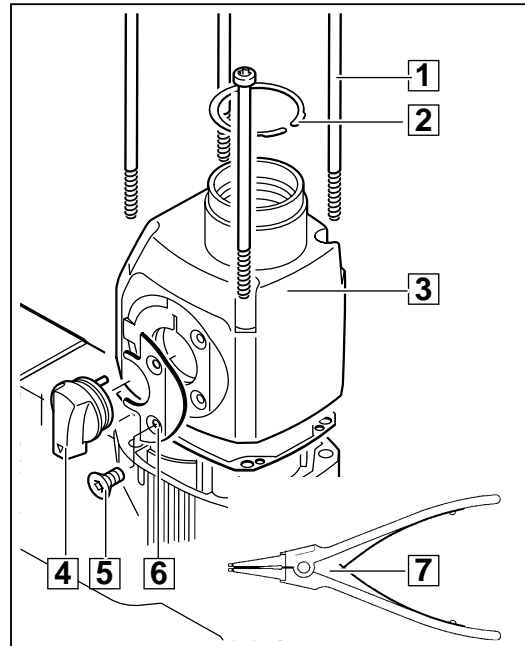

3

**Removing the spindle**

- 1 Remove the two screws (1).
- 2 Remove the straight pin (5).
- 3 Remove the planetary gear (4) and the ring gear (5).
- 4 Remove the complete spindle sleeve (2) from the cylinder.

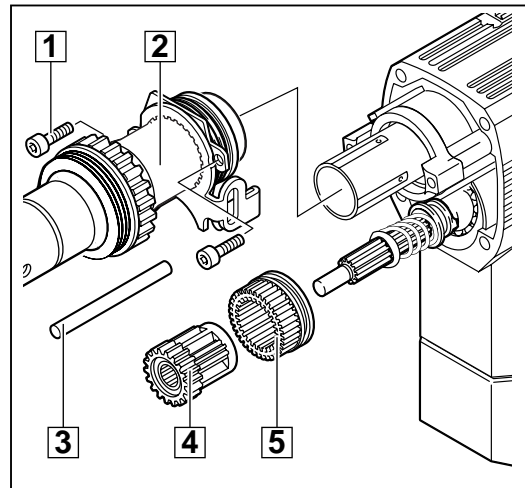

4

**Removing the striker**

- 1 Place the spindle vertically.
- 2 Briefly hit the plunger (1) with a mandrel. The striker (2) comes free.

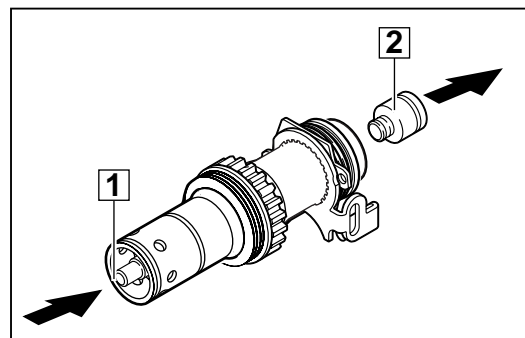

5

**Disassembling the spindle (removing the outer parts)**

- 1** Remove the locking washer (A).
- 2** Reduce the rear thrust bearing (9) to its component parts:
  - washer,
  - O-ring,
  - 2 compensating discs (thin) and
  - thrust bearing disc with washer (thick).
- 3** Remove the latch plate (8) and the locking slide (7).
- 4** Remove the spindle gear (4):  
Press the spindle gear (4) with a sleeve against the cup springs (1) – the spring ring (6) is released and can be removed with the pliers. Remove the disc (5). Remove the spindle gear (4) and the cylinder pulleys (3).  
Remove four balls (B).

 The dimensions for the sleeve can be taken from the below illustration!

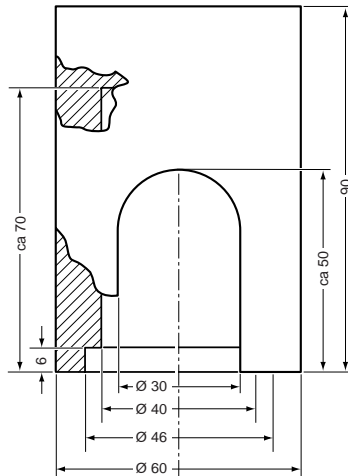

- 5** Remove the clutch disc (2) and the cup springs (1).

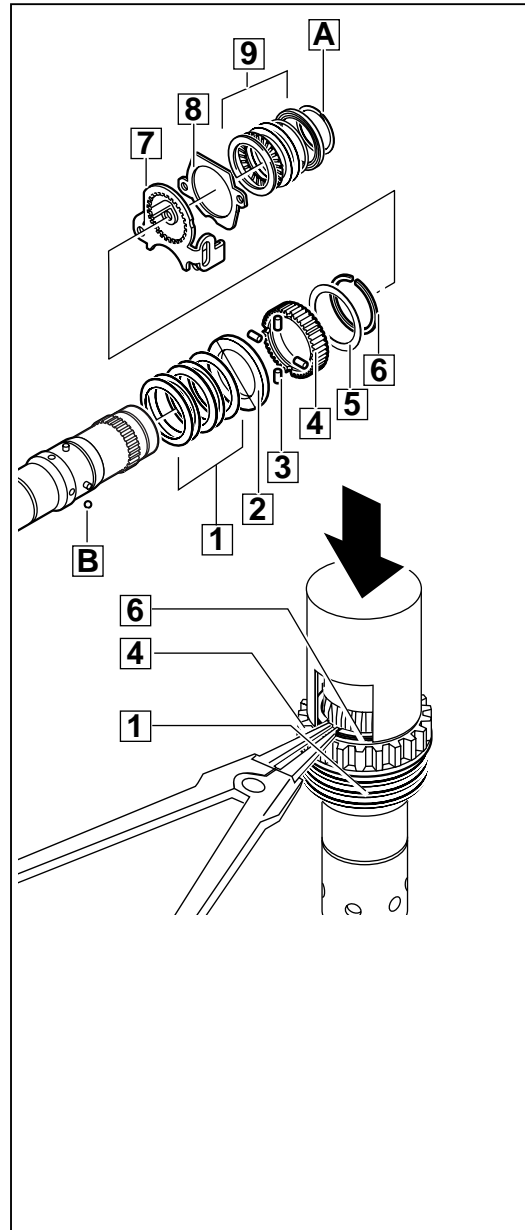

6

**Disassembling the spindle (removing the inner locking ring)**

 In the middle area of the spindle (1) there are four dearing holes and four service borings (3). The diameter of the service borings (3) is smaller than that of the dearing holes.

**1** Turn the round wire locking ring (2) with aid of the service tool (4931 599 084) such that one end projects the service boring (3) by approx. 2 mm.

**2** Put a screwdriver through the service boring (3) and place it under the locking ring (2).

**3** Move the screwdriver to and fro and at the same time turn the locking ring (2) with aid of the service tool in direction of arrow.

 Turn the locking ring (2) until it is completely levered off the groove.

**4** Press the locking ring (2) from the spindle.

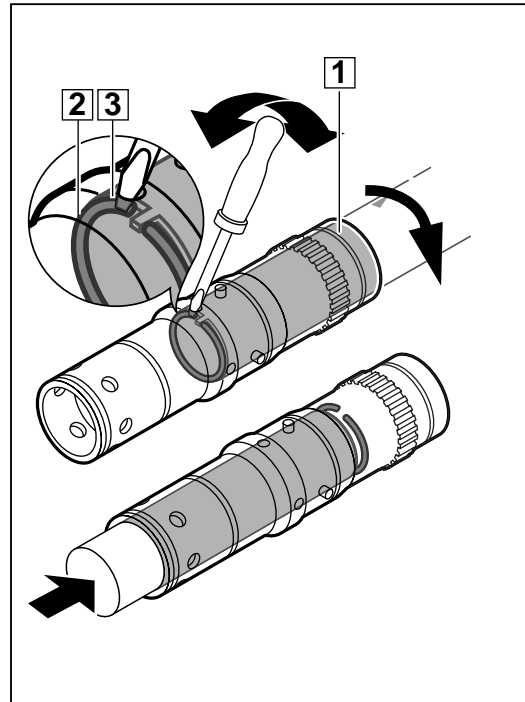

7

**Disassembling the spindle (removing the inner parts)**

**1** Remove the following parts from the spindle (1):

- thrust collar (8),
- O-ring (7),
- radial seal ring (6),
- sleeve (5),
- snap die (4),
- brake disc (3),
- seal ring (2).

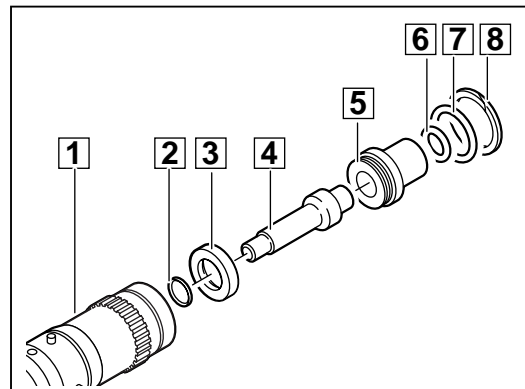

8

**Removing the reduction gear shaft and the cylinder**

**1** Pull out the bearing housing (4). If necessary, loosen the bearing housing (4) by hitting the gear housing lightly with a plastic hammer.

**2** Remove the reduction gear shaft (5) by turning or canting it (see arrow in illustration).

**3** Completely remove the cylinder (1) and the back gear.

**4** Push out the bolt (2) by hand and remove the two disks (3).

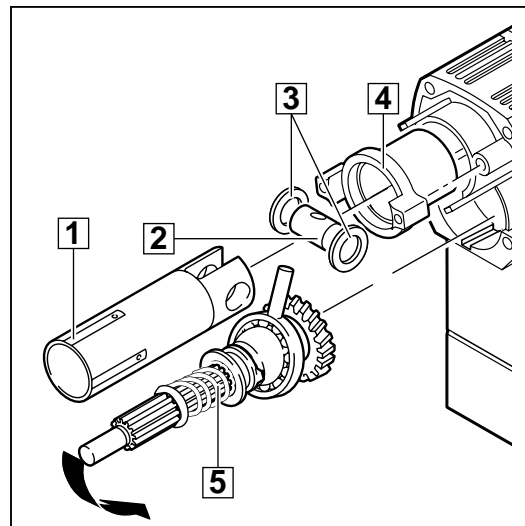

9

**Dismantling the reduction gear shaft**

- 1 Remove the O-ring (7).  
 Attention! The O-ring (7) fits tightly and only serves to lock the discs during (dis-) assembly of the reduction gear shaft.

---

- 2 Remove the washer (6) and the thrust bearing (discs (3), (4) and (5)).

---

- 3 Press off the reduction gear wheel (2).

---

- 4 Remove the following parts:
  - wobble drive (1),
  - coupling sleeve (B),
  - pressure spring (A),
  - disc (9).

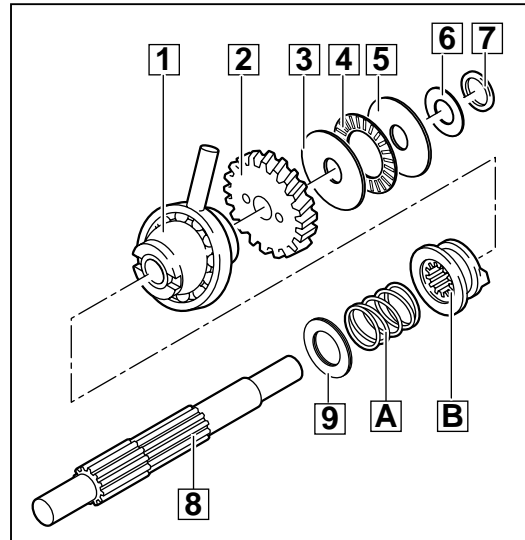

10

**Removing the pinion shaft**

- 1 Remove the locking ring (1).

---

- 2 Remove the pinion shaft (3) with disc (2) and ring (4).  
 If necessary, hit the gear housing lightly with a plastic hammer for support.

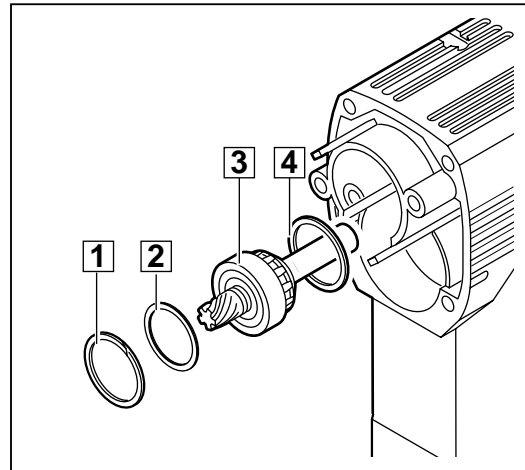

11

**Removing the motor cover**

- 1 Loosen the four screws (1) and remove the motor cover (2).

---

- 2 Remove the rubber cap (3) in case of damage.

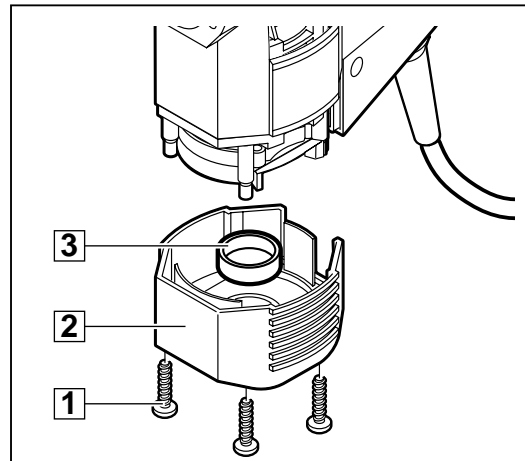

12

**Dismantling  
the handle**

- 1 Expel the pin (B).
- 2 Pull the field supply cables (A) from the contacts and remove them from the field housing.
- 3 Loosen the screw (8) and remove the gear cover (9).
- 4 Loosen the screws (6) and remove the handle cover (5).
- 5 Remove the washers (1) and (2).
- 6 Slightly pull back the handle and remove the damper element (3).
- 7 Remove the handle (4).
- 8 Unscrew and remove the handle bolt (7).

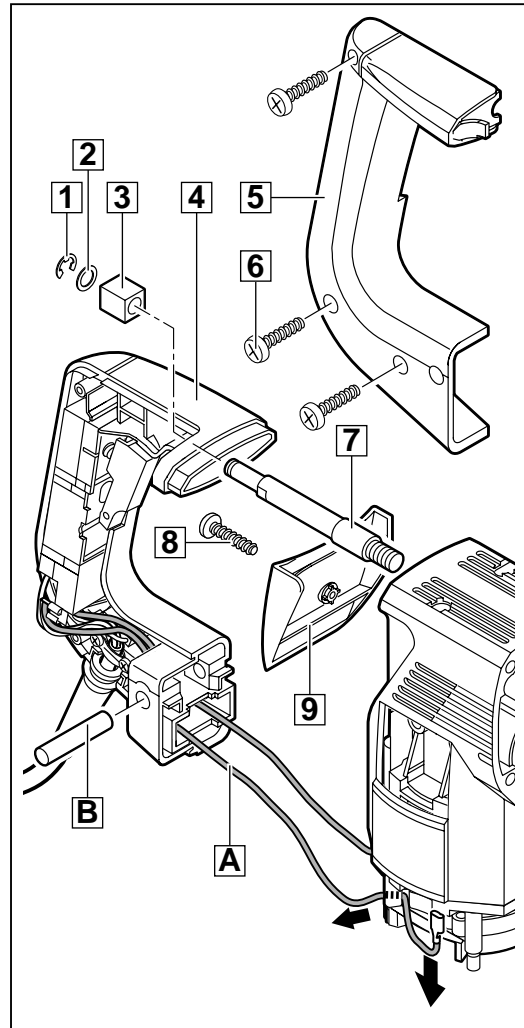

13

**Detaching  
the electric  
components**

- 1 Unscrew the strain relief (1).
- 2 Remove the following parts:
  - switch (2)
  - capacitor (4)
  - mains cable (5) and
  - field cable (3).

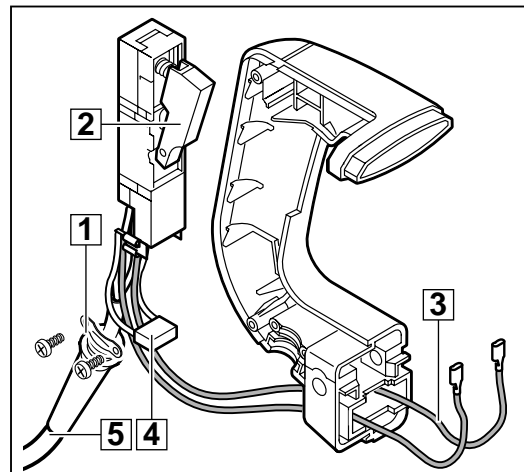

14

**Removing the motor**

- 1 Loosen the screws (1) and (4) and pull out the motor (3).
- ☞ If necessary, hit the motor housing (2) lightly with a plastic hammer for support.

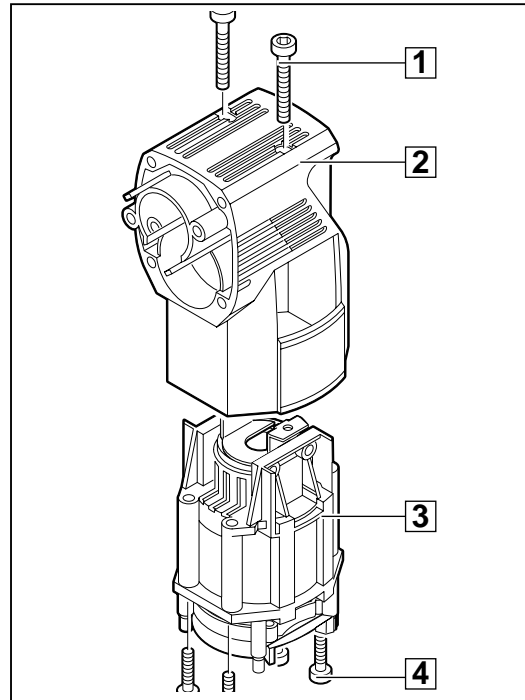

15

**Removing and dismantling the armature**

- 1 Remove the seal ring (A) and the O-ring (2).
- 2 Pull out the bearing cover (1) and remove the holding-down devices (B).
- 3 Pull out the complete armature (8).
- 4 Disassemble the armature (8) as follows:
  - press off the pinion shaft (3),
  - remove spacer (4) and sleeve (5),
  - press off the ball bearing (6) and the grooved ball bearing (9) with forcing discs,
  - remove the insulating disc (7).

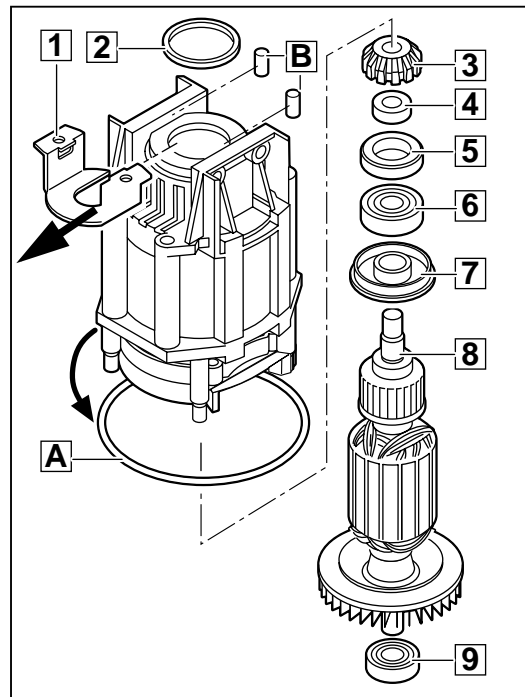

16

**Removing the field**

- 1 Remove the air deflector ring (1) and damaged silicone buffers (2).
  - 2 Pull the field (4) from the motor housing (5) and remove the centring ledges (3).
- ☞ If necessary, hit the motor housing lightly with a plastic hammer for support.

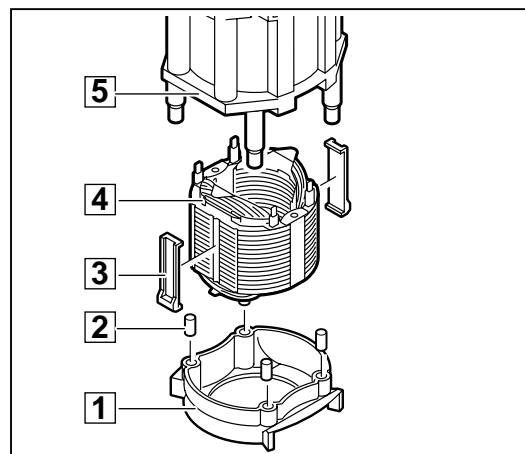

17



## Maintenance

### General

It is recommended to regularly submit the tool to maintenance, or as soon as the hammer mechanism gets weak, or when the carbon brushes switch off. When carrying out maintenance all parts of the maintenance set must be exchanged. Use the respective maintenance set provided for each machine.

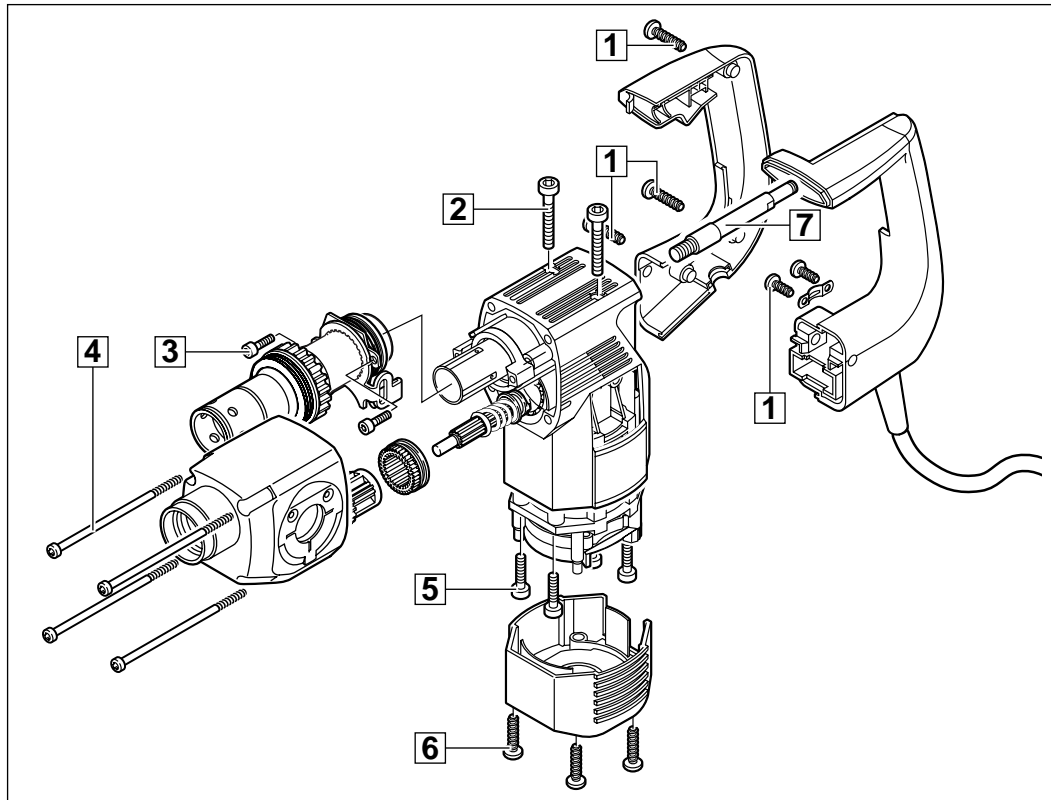

### Torques

Handle cover screws (1)	1.2 Nm
Motor screws (2)	2.5 Nm + screw locking agent
Spindle sleeve screws (3)	6.0 Nm + screw locking agent
Screws (4)	2.5 Nm
Motor screws (5)	2.5 Nm + screw locking agent
Motor cover screws (6)	1.8 Nm
Handle bolt (7)	10.0 Nm

**Cleaning** Clean all parts – with the exception of the electrical parts – with cold cleaning agent. Caution! No cleaning agent should penetrate into the bearing. Clean the electrical parts with a dry brush.

**Check for wear** Check the disassembled parts for wear (visual inspection) and replace worn parts.

**Electrical tests** Before reassembling, perform an electrical test on all relevant parts (see chapter Electrical and Mechanical Test Instructions).

**Lubrication** Each time maintenance is performed, the machine is to be lubricated as stated in the lubrication plan. After the machine is fully disassembled, completely remove the old grease and replace with new grease. The grease must be applied to the machine as indicated in the lubrication plan.

### Legend

**A** Thickly cover with a total of 31 g Darina grease (4931 622 229).

**B** Thinly cover with a total of 14 g Tivela grease (4931 215 436).

**C** Insert a total of 0.5 g Turmopast grease into the wobble gear boring (4931 379 848).

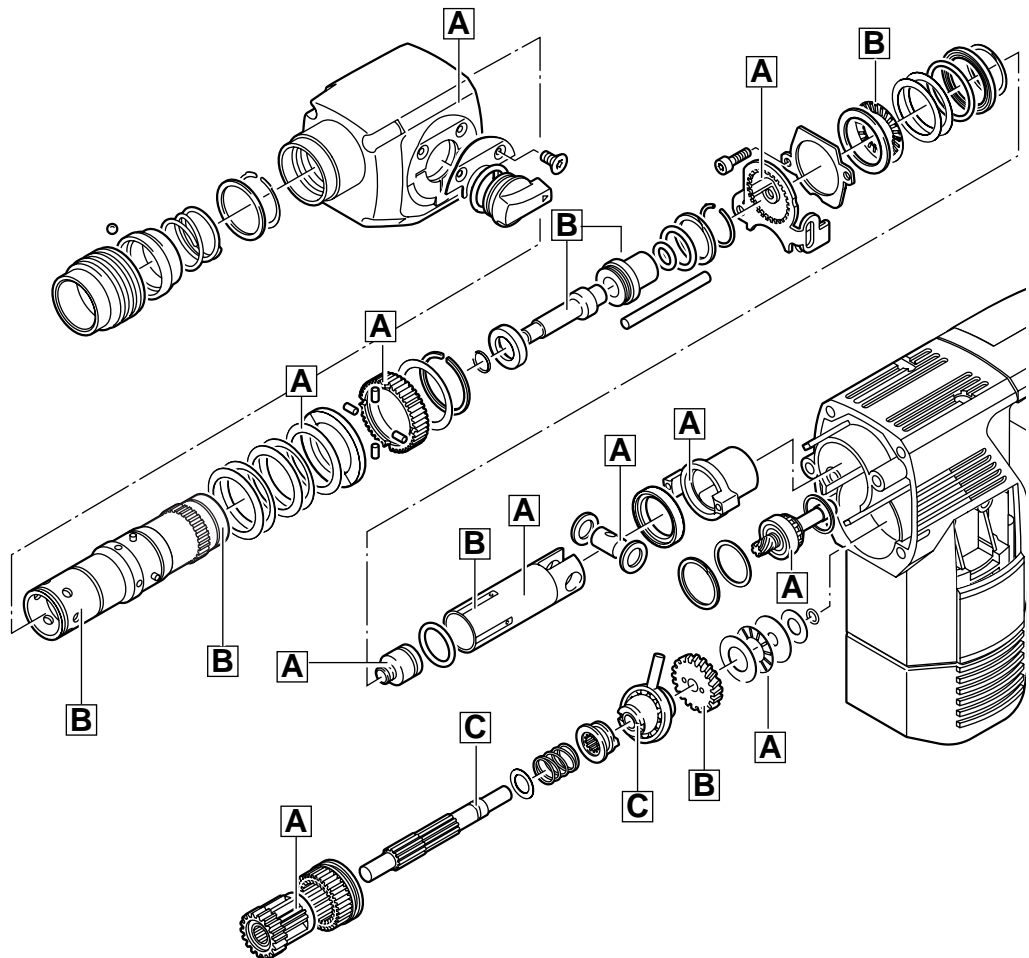

## Assembly

### Mounting the field

- 1 Place the centring ledges (3) on the field (4) (mind the right position, see illustration).
  - 2 Insert the field (4) into the motor housing (5), or press it in. If support is needed, lightly hit the motor housing with a plastic hammer from behind.
  - 3 If necessary, insert new silicone buffers (2) into the air deflector ring (1).
  - 4 Insert the air deflector ring (1).
-  The rounded corners of the air deflector ring (1) must face the centring ledge (3).

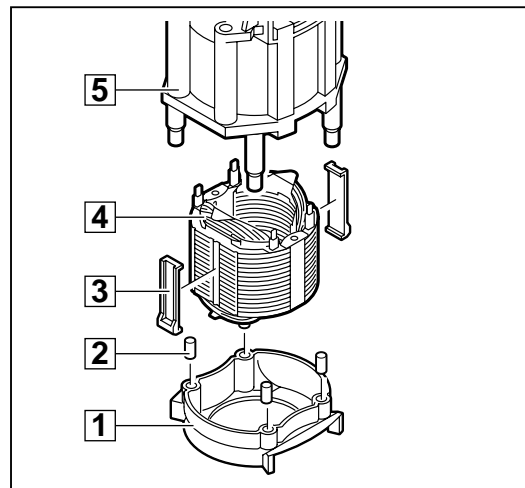

1

### Assembling and mounting the armature

- 1 Assemble the armature by pressing on the following parts:
    - the grooved ball bearing (9),
    - insulating disc (7),
    - ball bearing (6),
    - sleeve (5),
    - spacer (4),
    - press on the pinion shaft (3).
  - 2 Insert the completely assembled armature (8) into the field.
  - 3 Put the holding-down devices (B) on the field housing.
  - 4 Fix the armature with the bearing cover (1) in the field housing (insert it in direction of arrow).
-  The armature must rotate easily.
- 5 Put the seal ring (A) on the field housing and mount the O-ring (2).

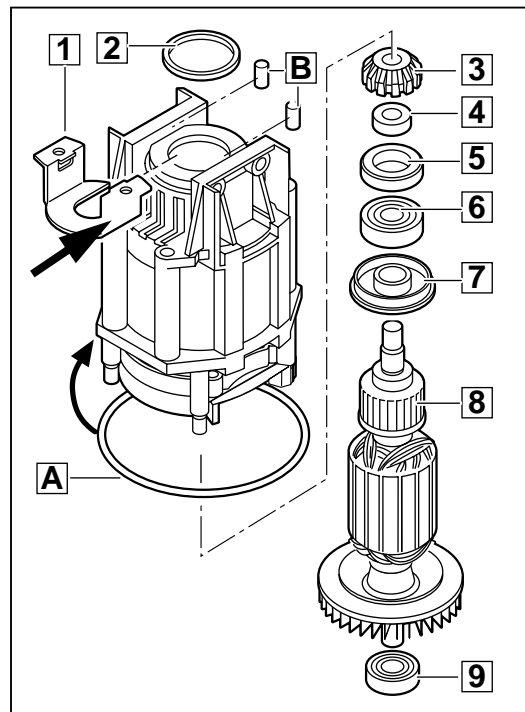

2

**Mounting  
the motor**

**1** Insert the motor (1) into the motor housing (3) (take care of the right position: the lug (4) must fit into the relief of the motor housing).

**2** Fasten the motor with the screws (2) and (5) (2.5 Nm).

 Use new screws (2) and (5) with micro encapsulation or cover the used screws with screw locking agent before assembly.

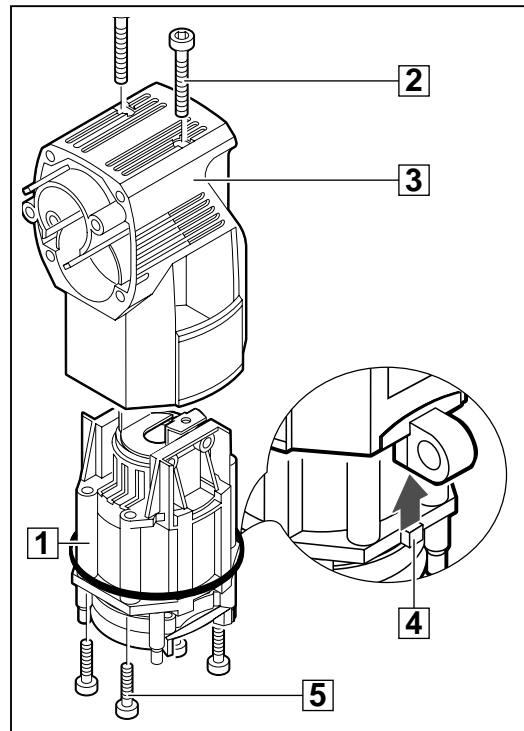

3

**Mounting  
the electric  
components**

**1** Connect all cables with the switch according to the wiring diagram.

**2** Lead the field supply cables (3) (black and yellow) through the handle as shown in illustration.

**3** Insert the switch (2) and the capacitor (4) into the provided relief.

**4** Insert the mains cable (5) into the handle.

**5** Screw down the strain relief (1) (1 Nm).

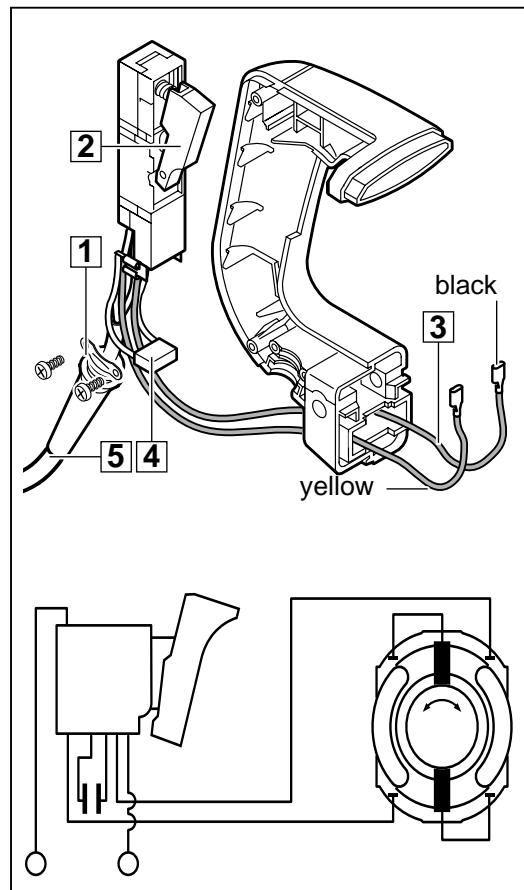

4

**Mounting  
the handle**

- 1 Cover the handle bolt (7) with locking agent, insert it into the housing and screw it down (10 Nm).
- 2 Push the handle (4) over the bolt and fasten the damper element (3) with the washers (2) and (1).
- 3 Fasten the handle cover (5) with the screws (6).
- 4 Fix the handle with the bolt (B). Press in the bolt (B) or knock it in with a plastic hammer.
- 5 Fit the gear cover (9) and secure it with the screw (8).
- 6 Lead the field supply cables (A) (black and yellow) through the channels of the field housing as shown in illustration. Connect them to the field diagonally.

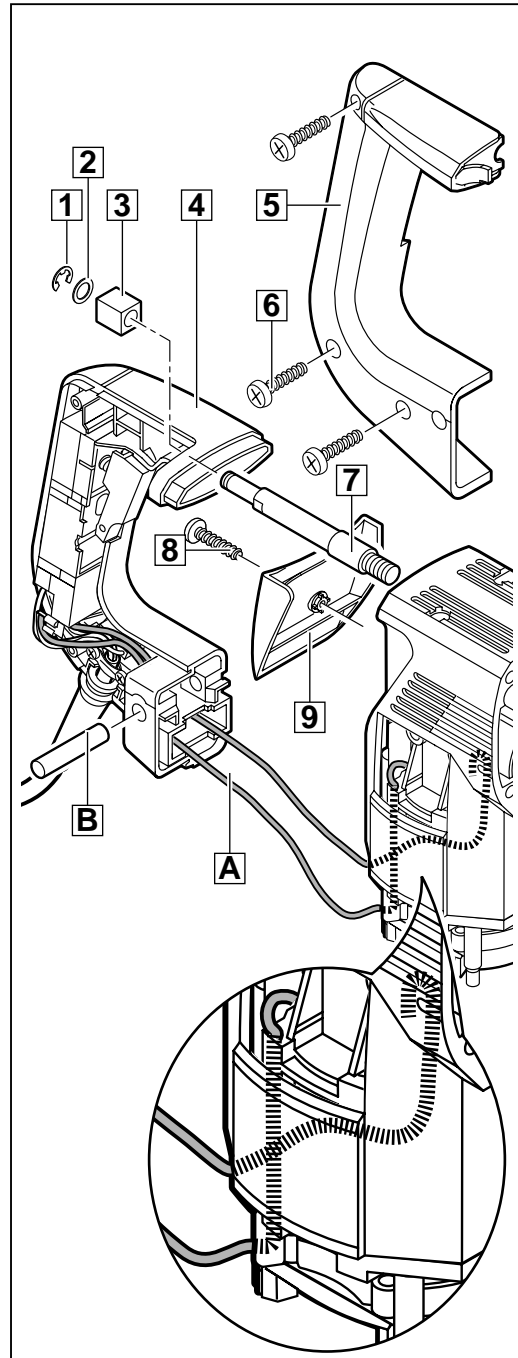

5

**Mounting the  
motor cover**

- 1 Fit the motor cover (2) (mind the right position) and secure it with the screw (1) (1.8 Nm).  
 Apply glue to the back of the rubber cap (3) and fix it in the motor cover (2).

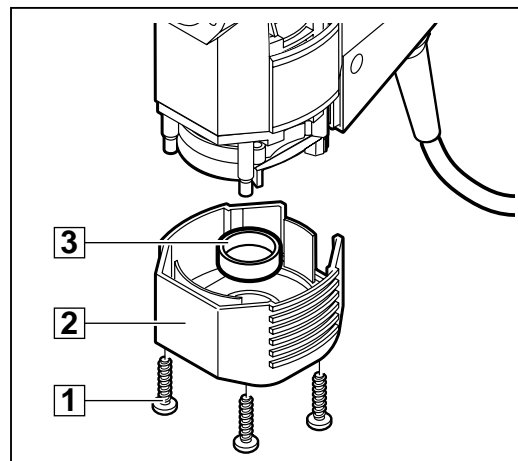

6

**Mounting the angle drive**

- 1 Insert the support ring (4).
- 2 Grease the angle drive (3) and insert it into the motor housing by turning it slightly.
- 3 Put on the disc (2) and mount the locking ring (1).

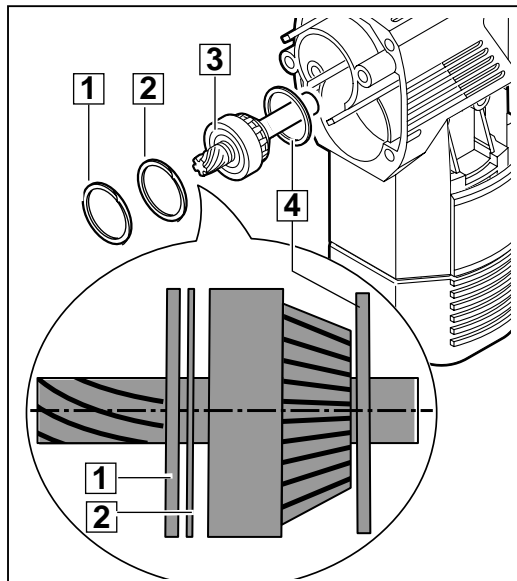

7

**Assembling the reduction gear shaft**

- 1 Assemble the reduction gear shaft (1) by mounting the following parts:
  - disc (9),
  - pressure spring (A),
  - coupling sleeve (B),
  - wobble drive (1).

- 2 Press on the reduction gear wheel (2). The smooth surface must face the wobble drive (1).

- 3 Lightly grease the thrust bearing (4) and put it together with discs (3) and (5) on the reduction gear wheel (2).

- 4 Fit the washer (6) and check the dimension "X1": For control dimension "X1":

Control dimension X1/mm	99.97-100.42	100.43-101.10
Compensation (disc a)	1 x 0.5	-

☞ Only insert disc "a" if the control dimension X1 is smaller than 100.42 mm.

- 5 Insert the O-ring (7). It only serves as mounting aid to keep the disc (6) locked.

- 6 Check dimension "X2": For control dimension "X2" applies:

Control dimension X2/mm	Compensation		
	Disc b: 1.0 mm	Disc c: 0.4 mm	Disc d : 0.2 mm
91.98 - 92.00	1x		1x
92.01 - 92.20	1x	1x	
92.21 - 92.40	1x		1x
92.41 - 92.60	1x		
92.61 - 92.80		2x	
92.81 - 93.00		1x	1x
93.01 - 93.20		1x	
93.21 - 93.40			1x
93.41 - 93.73	-	-	

☞ Choose a suitable disc according to control dimension X2 and insert it.

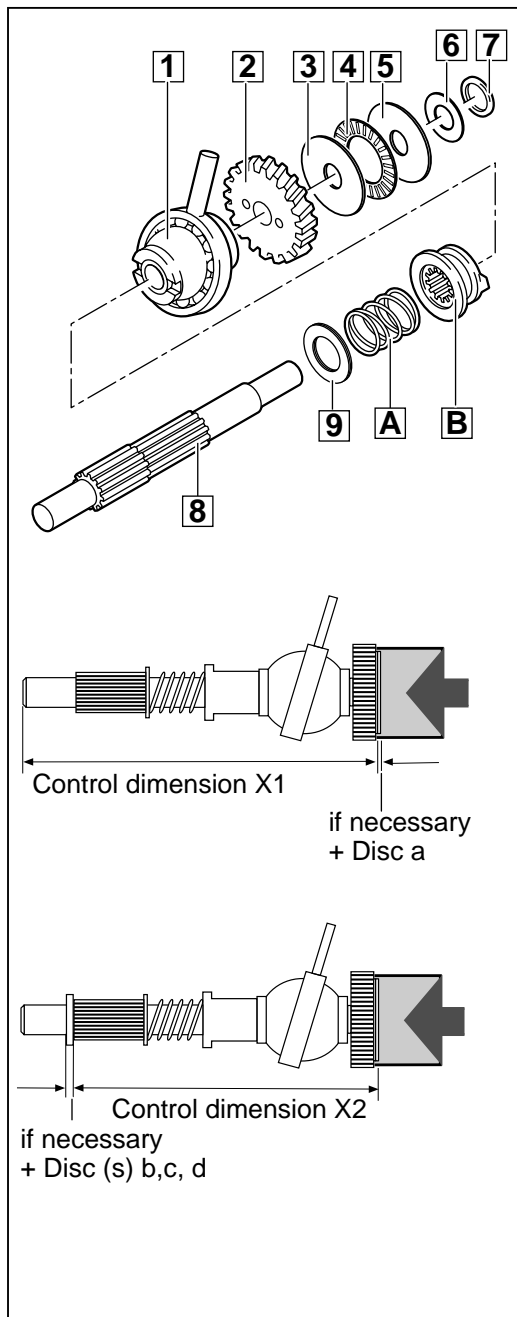

8

**Mounting the reduction gear shaft and the cylinder**

- 1 Insert the two disks (3) and the bolt (2) into the cylinder (1).

---

- 2 The reduction gear shaft (4) can only be inserted as follows:  
Put together the cylinder (1) and the reduction gear shaft (4) for adjustment before mounting them.

---

- 3 Grease the striker (5) and insert it into the cylinder (1).

 Insert the tumble drive into the cylinder and insert them together into the gear box.

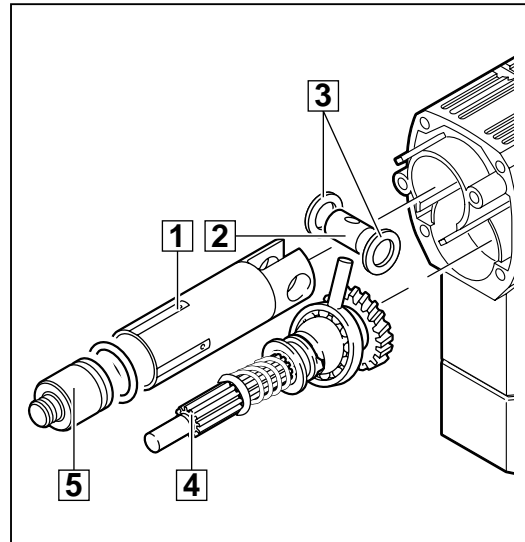

9

**Mounting the spindle bearing**

- 1 Press the sleeve (1) into the motor housing. Mind the right position!

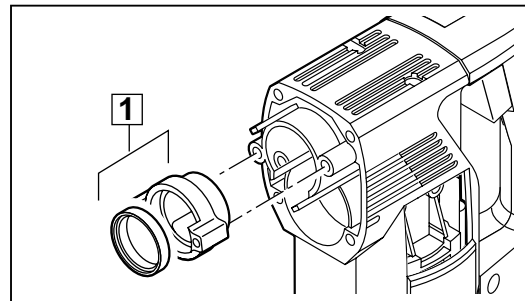

10

**Assembling the spindle (mounting the inner parts)**

- 1 Insert the following parts into the spindle (1):
  - seal ring (2),
  - brake disc (3),
  - snap die (4),
  - sleeve (5),
  - radial seal ring (6),
  - O-ring (7),
  - thrust collar (8).

---

- 2 Push the locking ring (9) into the spindle and let it engage.

 The cylinder (A) can be used for support.  
Check the proper seat of the locking ring: the first half of the cylinder borings (A) must be covered by the spindle sleeve (1).

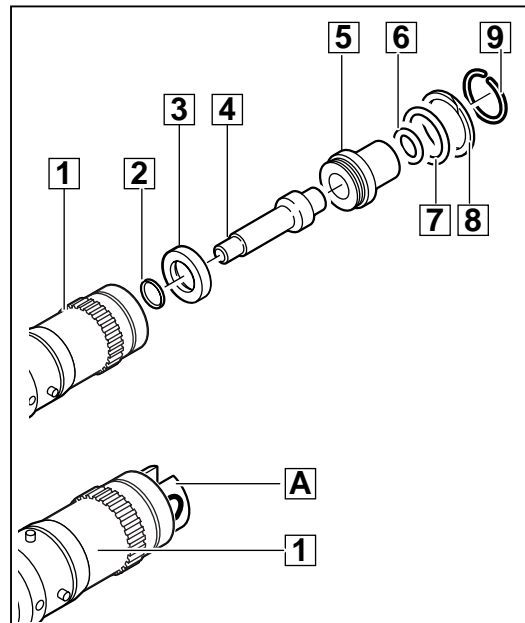

11

**Assembling the spindle  
(mounting the outer parts)**

- 1 Mount the cup springs (1) with the bulgings head-on (see illustration).
- 2 Mount the clutch disc (2).
- 3 Insert four balls (B) into the spindle and mount the spindle wheel (3) with the cylinder pulleys (A).
- 4 Mount the disc (4) and secure it with the spring ring (5).
- 5 Mount the locking slide (6) and the latch plate (7).
- 6 Mount the rear thrust bearing (8):
  - washer
  - O-ring
  - two compensating discs
  - thrust bearing disc with washer.
- 7 Mount the locking washer (9).

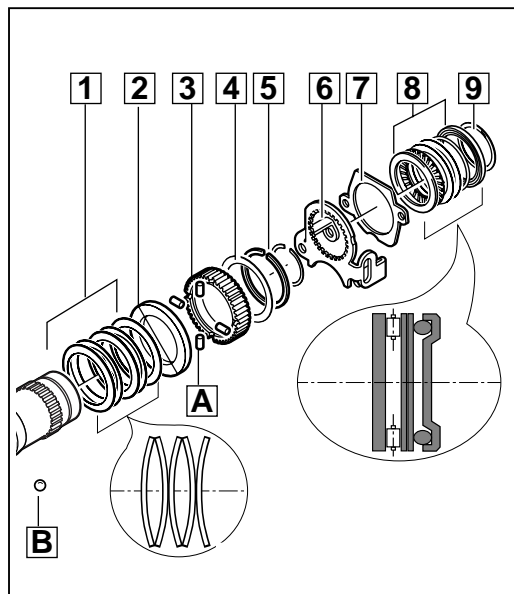

12

**Mounting the spindle**

- 1 Fit the spindle (2) to the motor housing (4) and fasten it with two additionally secured screws (1) (6 Nm).
- 2 Push the ring gear (6) over the reduction gear shaft (5) and let it engage in the locking slide (3).
- 3 Push the planetary gear (7) over the reduction gear shaft (5) and fit it into the ring gear (6). Mount the disc (9) and further spacers, if necessary.
- 4 Push the straight pin (8) through the locking slide (3) and insert it into the motor housing (4).

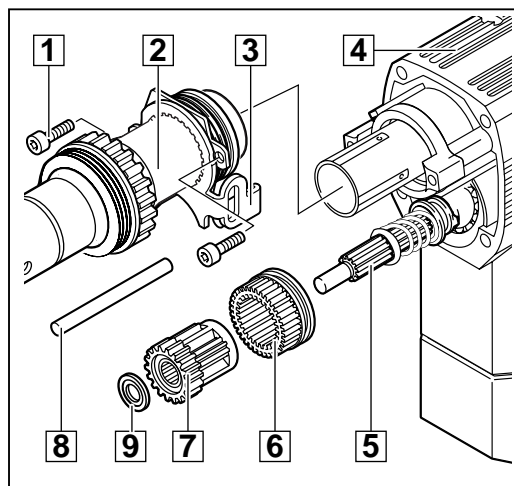

13

**Mounting the gear housing**

- 1 Insert the sleeve (1) (service tool) into the gear housing (2) (the sleeve protects the rotary shaft seal in the gear housing from damage during assembly).
- 2 Fit the gasket (3) to the motor housing (4).
- 3 Fit the gear housing (2) to the motor housing (4) and screw it down (2.5 Nm).
- 4 Screw down the holding-down device (5) and the switch lever (7) with two screws (6) and push in the switch lever (7).

☞ The pin (8) of the switch lever must fit into the long narrow hole of the locking slider (9).

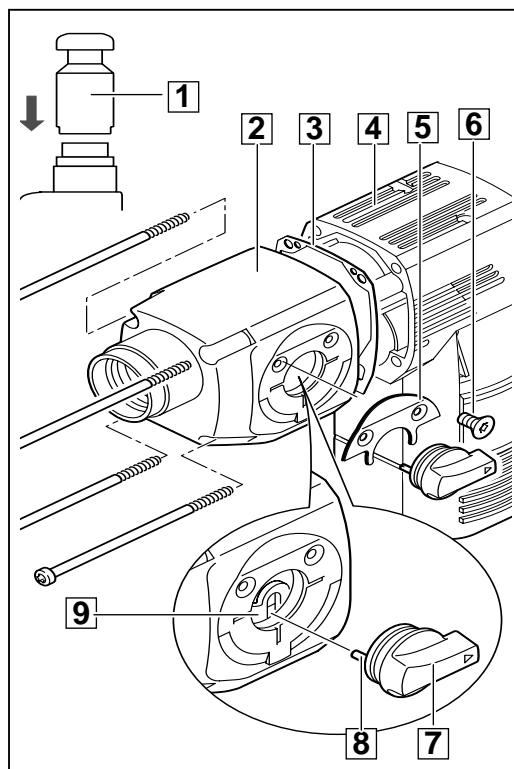

14



**Mounting the  
FIXTEC receiver**

- 1** Push in the locking ring (2) with aid of the sleeve (1) (service tool) and let it engage.
- 2** Mount the following parts in the below order:
  - disc (8)
  - pressure spring (7) and
  - seal ring (6).
- 3** Depress the seal ring (6) and insert six balls (5).
- 4** Mount the locking sleeve (4).
- 5** Mount the locking ring (3).

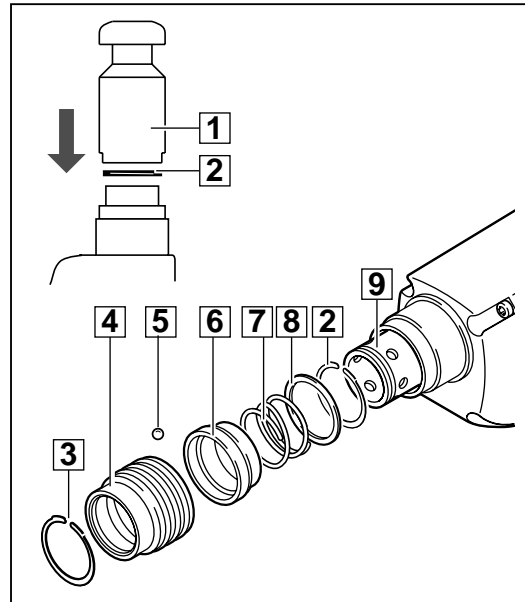

**15**

**Mounting the  
carbon brushes**

- 1** Insert each carbon brush holder (4) into the housing and connect the cables (3) with the field.
- 2** Insert each carbon brush (1) into the respective carbon brush holder (4) and place the spring (2) on the carbon brush (1). Fit the flat plug.
- 3** Fasten the service covers (6) with screws (5).

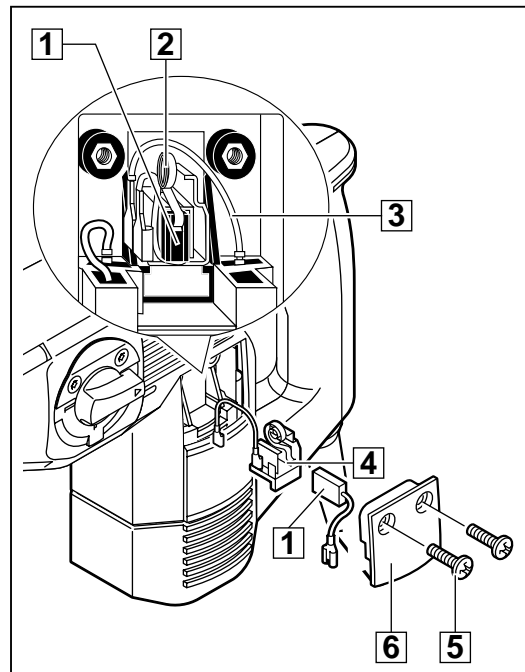

**16**

**Test Run**

Test run the machine and pay attention to noises.  
Let the machine run-in.

**Electrical Test**

Perform an electrical test on the machine (see chapter Electrical and Mechanical Test Instructions).